

| | CLAMPING RANGE | | | |
|-----------|----------------|---------|-------------|------|
| | INCHES | | MILLIMETERS | |
| | MIN. | MAX. | MIN. | MAX. |
| THCSS-06 | 7/16 | 7/8 | 11 | 22 |
| THCSS-08 | 7/16 | 1" | 11 | 25 |
| THCSS-10 | 1/2 | 1 1/8 | 13 | 29 |
| THCSS-12 | 1/2 | 1 1/4 | 13 | 32 |
| THCSS-16 | 1/2 | 1 1/2 | 13 | 38 |
| THCSS-20 | 1/2 | 1 3/4 | 13 | 44 |
| THCSS-24 | 1/2 | 15/16 | 13 | 49 |
| THCSS-28 | 5/8 | 2 3/16 | 16 | 56 |
| THCSS-32 | 7/8 | 2 7/16 | 22 | 62 |
| THCSS-36 | 1" | 2 11/16 | 25 | 68 |
| THCSS-40 | 1 1/4 | 2 15/16 | 32 | 75 |
| THCSS-44 | 1 1/2 | 3 3/16 | 38 | 81 |
| THCSS-48 | 1 9/16 | 3 7/16 | 40 | 87 |
| THCSS-52 | 1 13/16 | 3 11/16 | 46 | 94 |
| THCSS-56 | 2 1/16 | 4 | 52 | 101 |
| THCSS-64 | 2 9/16 | 4 7/16 | 65 | 113 |
| THCSS-72 | 3 1/16 | 4 15/16 | 78 | 125 |
| THCSS-80 | 3 9/16 | 5 7/16 | 90 | 138 |
| THCSS-88 | 4 1/16 | 5 15/16 | 103 | 151 |
| THCSS-96 | 4 9/16 | 6 7/16 | 116 | 163 |
| THCSS-104 | 5 1/16 | 6 15/16 | 129 | 176 |
| THCSS-108 | 5 5/16 | 7 3/16 | 135 | 183 |
| THCSS-112 | 5 9/16 | 7 7/16 | 141 | 189 |
| THCSS-116 | 5 13/16 | 7 11/16 | 148 | 195 |

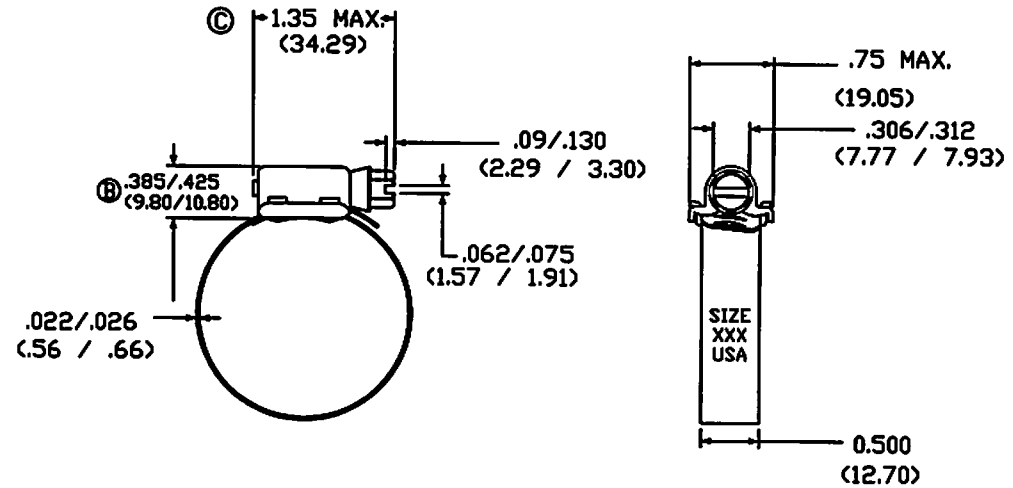

STRAP= 300 SERIES ST.STL.
HOUSING= 300 SERIES ST.STL.
CLIP= 300 SERIES ST.STL.
SCREW= 300 SERIES ST.STL. DR ZINC PLATED 1018

(A)

Performance Test

Maximum free running torque to be 3 in. lbs.
Clamp must be able to absorb 60 in lbs. of torque applied with a hand torque wrench without failure.
Clamp shall be free of burrs, seams, laps, loose scale, or any other defects that may affect their serviceability.

| | | | |
|---|------------------------------|---|-----------------------------|
| Ⓒ | CHANGE TO SAE J1508 STD. DIM | C. HEUER | 9/08/04 |
| Ⓑ | HOUSING DIM. WAS .46 (REF.) | C. HEUER | 11-20-03 |
| Ⓐ | ADDED ZINC PLATED 1018 SCREW | C. HEUER | 10-06-03 |
| REV. | WAS | CHANGED BY | DATE |
| Information Contained In This Document Is Considered By Tiewraps.com. To Be Confidential And Is Not To Be Used In Any Manner Without Their Consent. | | Tiewraps.com Inc. P.O. Box 421132 San Diego, CA 92142 | |
| UNLESS OTHERWISE SPECIFIED | | TITLE- | |
| FRAC± | 4 PLC± | ½ Clamp General Description | |
| 2 PLC± | ANGLE± | DR.BY- | J.Sans |
| 3 PLC± | | DATE- | 02-28-02 |
| MAT'L- | | APP.BY- | |
| FINISH- | | DATE- | 02-28-02 |
| | | SCALE- | |
| | | | -DWG.NO.- 13-10-000013 B |