

Infrared Direct Air Heater

with Thermostatic Control

125,000BTU - Diesel/Kerosene/Paraffin



INFERNO iR125

JEFHTRAD125TC

User Manual

v.1.1



CONTENTS

Contents	3
About This Document	3
Introduction	4
Specifications	4
Equipment Identification	4
Safety Guidelines	5
Working Environment	7
Clearance Requirements	7
Unpacking & Assembly	8
Operating Principle	9
Circuit / Wiring Diagram	10
Operating Instructions	10
Maintenance	11
Troubleshooting	11
Parts Diagram	12
Parts List	13
Energy Related Products (ErP) Directive Information	14
Environmental Protection	15
Limited Warranty Statement	15
EU & UKCA Declaration Of Conformity	15

ABOUT THIS DOCUMENT

This manual has been compiled by Jefferson Tools and is an integrated part of the product with which it's enclosed and should be kept with it for future reference. Please read all of the information supplied in this User Manual before operating this product.

This manual describes the purpose for which the product has been designed and contains all the necessary information to ensure its correct and safe use. We recommend that you read the information supplied before carrying out any maintenance or repair. By following all the general safety instructions contained in this manual you will help to ensure operator safety and extend the potential life span of the equipment.

All photographs and drawings in this manual are supplied by Jefferson Tools to help illustrate the operation of the product. Whilst every effort has been made to ensure accuracy of information contained in this manual our policy of continuous improvement determines the right to make modifications without prior warning.

Contact your nearest Jefferson Dealer if you are unsure about any information included in this manual or require any additional information about the safe use, operation, maintenance, or repair of this equipment.

INTRODUCTION

- The Jefferson iR125 Infrared Direct Oil Heater produces 125,000 BTU/H (36.6kW) of infrared heat which is ideal for heating large well-ventilated spaces including garages and warehouses
- Suitable for use with diesel, kerosene or paraffin fuel
- Equipped with a durable 40L steel fuel tank with an economical average fuel consumption of 3.44 L/Hour
- Includes an LED thermostatic control with automatic cut-off for cost savings from reduced energy and fuel usage
- With a timed ventilation system to help cool the combustion chamber
- Designed with a tough powder-coated housing to enhance protection from the elements and the working environment
- Fully tested and certified to the latest UKCA / CE standards and ERP (Energy Related Product) compliant

SPECIFICATIONS

Voltage ~ Frequency:	230V ~ 50Hz
Power:	59W
Heat Output:	125,000 BTU/H • 31,499 Kcal/H (36.6kW)
Average Heating Capacity:	280m ²
Fuel Consumption:	3.44 L/Hour
Fuel Type:	Diesel / Kerosene / Paraffin
Fuel Tank Capacity:	40L
Maximum Running Time:	12 Hrs
Dimensions (LxWxH):	116 x 696 x 930cm
Weight:	43kg

EQUIPMENT IDENTIFICATION

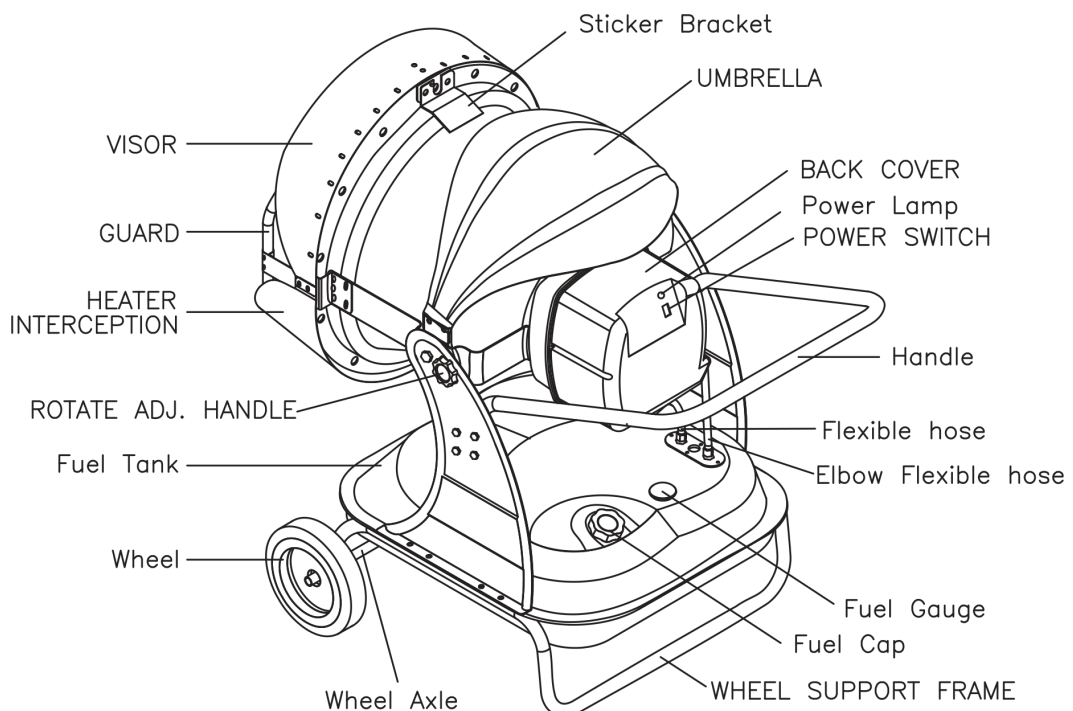

SAFETY GUIDELINES



Please read and ensure that you understand all of the operating instructions, safety precautions and warnings in this Instruction Manual before operating or maintaining this equipment. Save this user manual and keep it with the equipment for future reference. An accident can often be avoided by recognizing a potentially hazardous situation before it occurs, and by observing the appropriate safety procedures.



Never use this equipment or modify it in any way that has not been specifically recommended by the manufacturer. Ensure that the heater is maintained, cleaned and serviced regularly and stored in a suitable environment. Check the equipment for any signs of damage before use. Contact a qualified electrician for advice on any issues relating to electrical safety in your working environment.

GENERAL EQUIPMENT SAFETY

- When using your heater, basic safety precautions should always be followed to reduce the risk of fire, electric shock, personal injury and / or damage to the heater.
- Familiarise yourself with the specifications, fuel and electrical supply requirements, equipment controls, warning labels and operating instructions before use.
- Do not use this heater in damp or wet locations, including bathrooms or similar or expose it to rain.
- Never operate this heater in explosive atmospheres, or in environments that contain flammable liquids, gases, dust or other combustible sources.
- Keep children, pets, animals and untrained personnel away from the work area during operation.
- The heater should be stored in a dry, secure location when not in use.
- Do not alter the machine in any manner which might cause any risk to its safe operation.
- Keep work area clear around the machine. Cluttered areas can cause accidents and injuries.
- Check the equipment and cabling before use. Never use the heater if any damage is detected. Contact Jefferson Tools for help and advice on all aspects or repair or maintenance of this equipment.
- Only use Jefferson approved replacement parts to ensure safe use of the equipment and avoid invalidating the warranty. Always use a qualified engineer to carry out repairs.
- Do not allow untrained persons to operate the heater and do not operate the heater without all covers and housing correctly fitted.
- Do not move or handle the heater when it is running or still hot - always turn it off and allow it to cool first.
- Do not leave the heater unattended when in use. Switch the heater off and unplug from the mains supply before leaving the work area.
- Do not obstruct the air inlet (rear) or air outlet (front) of the heater.
- Do not use any form of ducting in front or at the rear of the heater.
- Only use the heater in an upright position on a level surface with sufficient clearance (see page 7)
- Never stand on the heater
- **Warning:** Small quantities of Carbon Monoxide are released during the combustion process ensure this equipment is only ever operated in safe working environments with sufficient ventilation. Stop the heater immediately if any symptoms are experienced (dizziness, headache, nausea etc.) and seek medical advice.



WARNING:

No responsibility is accepted for incorrect use of this equipment. Incorrect use can result in damage to the equipment and danger to the user. Warranty will be void in the event of incorrect use. The warnings, cautions and instructions discussed in this instruction manual cannot cover all possible conditions and situations that may occur. It must be understood by the operator that common sense and caution are factors which cannot be built into this product, but must be supplied by the operator.

ELECTRICAL SAFETY



Ensure that you check the equipment thoroughly to ensure it is safe and fit for purpose before each use. It is important that you inspect all plugs, sockets, power cables and electrical fittings for wear and damage and repair or replace any defective components. The risk of electric shock can be minimised by the correct use of the appropriate electrical safety devices.

- We recommend that you fit a Residual Current Circuit Breaker (RCCB) in the main distribution board and that a Residual Current Device (RCD) is used when operating this equipment.
- The Electricity at Work Act 1989 includes legislation that places legal implications on employers to ensure the safety of electrical devices in the workplace. The regulations dictate that all portable equipment must be inspected regularly and tested to ensure that it is safe for use. 'Portable equipment' means any electrical item that can be moved and this is often referred to as Portable Appliance Testing (PAT). PAT testing should be carried out regularly on this equipment by trained, authorised personnel, as required by the legislation.
- The Health and Safety at Work Act 1974 states that it is the responsibility of the owner of electrical appliances to ensure that both the equipment and working environments are maintained to ensure safe operation at all times.
- Check that all equipment cables are secure, correctly insulated, free from damage, and protected against short circuit and overload before connecting to the power supply. Do not use worn or damaged cables, plugs, sockets or other fittings.
- Ensure that the power supply matches voltage requirements specified on the equipment and that the plug is wired correctly and fitted with the correct fuse.
- If the electrical fuse blows, ensure it is replaced by an identical type of fuse with the same rating.
- Never pull or manoeuvre this equipment into position using the power cable.
- Ensure the power cable is kept away from heat, oil and sharp edges.
- We recommend that the equipment is connected directly to the power supply without the use of extension leads as the resulting voltage drop can reduce motor performance.
- Always disconnect the equipment from the power source before servicing, inspecting, maintaining, cleaning, replacing or checking any parts.

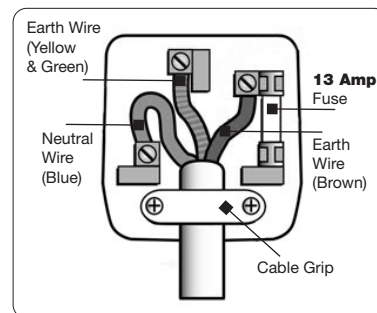

WORK AREA SAFETY

- Always ensure a sufficient working area, that is clean and tidy, and free access to the machine and peripheral devices.
- Ensure sufficient lighting is available in the working area which will not create shadows or cause a stroboscopic effect.
- Disconnect the heater from the mains supply when not in use.
- Avoid unintentional starting: Make sure the switch is in the "OFF" position before connecting the heater to the mains supply.
- Never carry the heater by the mains lead or pull it to remove the plug from the mains socket. Keep the mains lead away from heat, oil and sharp edges.
- If the mains lead is damaged, it must be replaced by the manufacturer or its service agent or a similarly qualified person in order to avoid unwanted hazards.
- Do not expose the heater to water spray, rain, dripping water or moisture of any kind.
- Do not touch the heater outlet or any internal parts when first switched off as these can be hot and will take time to cool.
- Ensure that the heater is correctly turned off when not in use and stored in a safe, dry area, out of reach of children.
- Do not unplug the heater to switch it off - always use the ON / OFF switch on the control panel and allow the cooling fan to run and automatically stop (after approximately 3 minutes) before disconnecting from the mains supply.

WARNING: Do not use the heater near flammable material, liquids, solids, gases or compressed gas cylinders. Do not direct the front of the heater towards any combustible materials (e.g. wooden items, cloth, plastics, paper).

WORKING ENVIRONMENT



WARNING! Only operate and refuel/fuel the heater in well ventilated areas. Careful consideration must be given to the placement of the heater to provide safe and comfortable heating. Ensure continuous ventilation is provided to the heater operating area. A ventilation opening must run to the outside of the premises in which the heater is to be operated

WARNING: Small quantities of Carbon Monoxide are released during the combustion process ensure this equipment is only ever operated in safe working environments with sufficient ventilation. Stop the heater immediately if any symptoms are experienced (dizziness, headache, nausea etc.) and seek medical advice.

WARNING! Air contaminants taken into the heater may affect the heat output, damage the heater and may cause health problems.

Example: Body-shop filler dust/paint overspray will damage the motor bearing, clog the filter and compressor and contaminate the combustion chamber causing flame flutter and health hazards.

Please note that any parts damaged by filler dust/paint overspray or similar will not be covered by warranty.

CLEARANCE REQUIREMENTS

Always provide adequate space around the heater as shown in the diagram and table in **Fig.3** below:

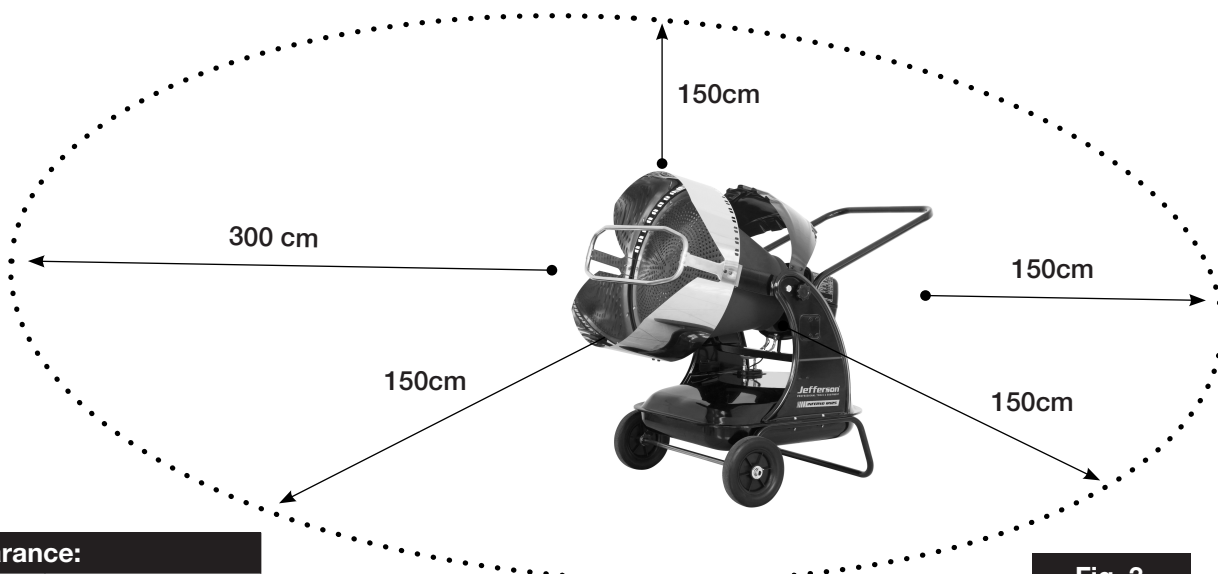
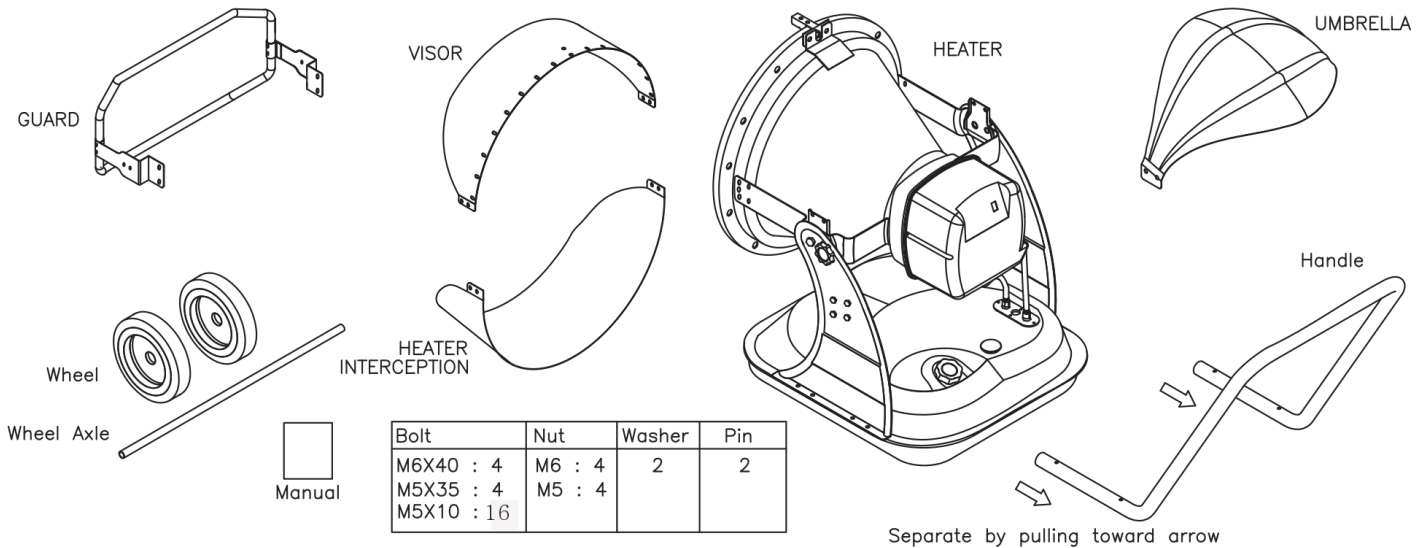

Fig. 3

Clearance:	
Top:	Top - 150cm
Sides:	Sides - 150cm
Rear:	Rear - 150cm
Front:	Front - 300cm

UNPACKING & ASSEMBLY

Open the packing box and take out the heater, accessories and manual etc then check.
For the contents, refer to the picture.



Assembling. 1

Open the box and take out the Heater. Separate the handle, inserted in Heater by pulling toward arrows

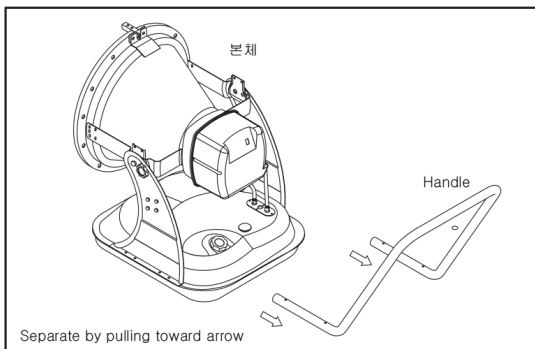

Assembling. 2

Fix the handle tightly according to the direction on diagram with Bolt(M6X40) and Nut

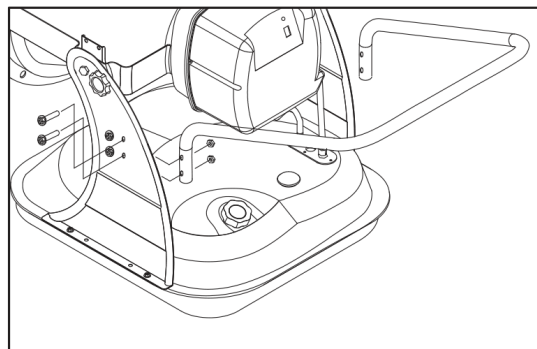

Assembling. 3

Assemble the Heater on appointed position of wheel Support Frame(described on diagram) with Bolt(M5X35) and Nut According to diagram. After assembling wheel and Wheel Axle, and fix with washer and pin.

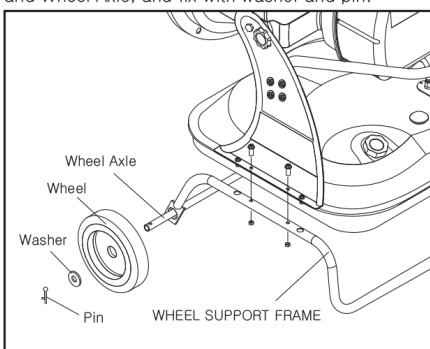

Assembling. 4

Assemble the Guard using M5X10 Bolt.

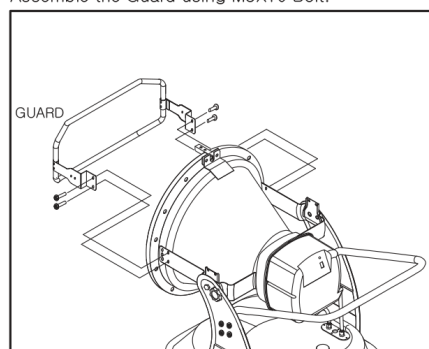

Assembling. 5

Assemble Visor, Heater Interception and Heat umbrella on the main body using M5X10 Bolt.

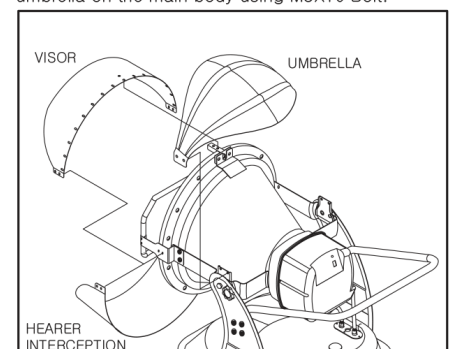

OPERATING PRINCIPLE

The Jefferson iR125 Direct Oil heater produces up to 125,000BTU/H (36.6kW) of infrared heat, which warms objects rather than the air.

Infrared is the same heat we feel from an environment warmed by the sun and makes this heater an ideal solution for heating large well-ventilated spaces like garages and warehouses.

Airflow is necessary to ensure proper combustion; It is supplied by the internal burner fan. The air enters the burner funnel and gets mixed with a high-pressure fuel jet.

The fuel flow is supplied by an electrical pump, which sucks the fuel from the tank and moves it to the nozzle under high pressure.

The iR125 heater is fitted with safety cut-outs to protect against over-heating and to protect the heater should it tip over.

The heater is also equipped with a clean and efficient burning unit which operates on diesel, kerosene or paraffin.



WARNING: Do Not Use Petrol or Gasoline Fuel With This Heater!

Please Note: When using the heater for the first time, you may notice a slight emission of smoke, or a slight burning smell. This is normal and will stop after a short time. Parts of the heater were coated with protection oil during production. The smoke / smell is caused by any small residue of this oil.

CIRCUIT / WIRING DIAGRAM

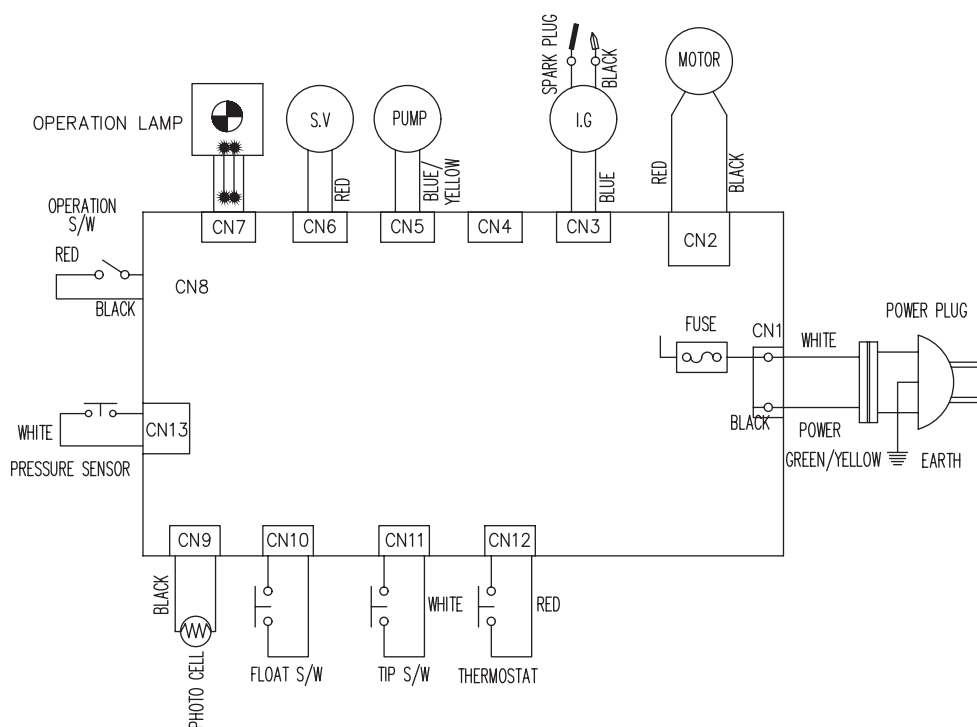

MAIN CONTROL PCB

OPERATING INSTRUCTIONS

STARTING THE HEATER

1. Fill the fuel tank until the fuel gauge points to "F".
2. Ensure the fuel cap is securely replaced.
3. Plug the mains lead into a suitable power socket and turn the mains switch on.
4. Push the Power switch on the control panel to the "ON" (I) position.

Note: *The temperature that the thermostat is set to will be shown on the display: If the set temperature is lower than the ambient temperature, the heater will not run and after a few seconds the ambient temperature will show on the display.*

5. To start the heater, turn the thermostat control clockwise to raise the set temperature (as shown on the display) above the ambient temperature and the heater will run. If the set temperature is higher than the ambient temperature the heater will start to run.
6. Once running the ambient temperature will show on the display.

The set temperature can be adjusted at anytime during operation; Turn the thermostat control left to lower the temperature and clockwise to raise the temperature, at this time the temperature on the display indicates the set temperature and after a few seconds it will change to the ambient temperature.

The heater will run until the ambient temperature goes above the set temperature, at which point the heater will automatically stop running until the ambient temperature drops below the set temperature, or the thermostat is turned up.

STOPPING THE HEATER

1. Turn the power switch to the "OFF" (0) position.
2. Combustion will stop and the cooling cycle will begin.
3. When cooling cycle has been completed and the fan stops running (approximately **3 minutes**), it is safe to turn off and unplug the heater at the mains supply.



WARNING! *Do not turn the mains switch off or disconnect the heater from the mains supply to stop the heater or until the cooling cycle is complete. Turning the mains switch off, or removing the plug from the mains supply to stop the heater or before the cooling cycle is complete may cause overheating, possible damage to the heater and will void the warranty.*

MAINTENANCE

Component:	Frequency:	Procedure:
Fuel Tank	Clean every 150-200 hours of operation or when necessary.	Empty and rinse with fresh fuel.
Nozzle	Clean or replace once per season or when necessary.	Contact Jefferson Tools or Service Centre.
Photocell	Clean once per season or when necessary.	Contact Jefferson Tools or Service Centre.
Fuel Filter	Clean or replace twice per sea- son or when necessary.	Clean the fuel filter with clean fuel.
Ignition Device	Clean or replace every 1000 hours of operation, or when necessary.	Contact Jefferson Tools or Service Centre.
Fan Blades	Clean when necessary.	Contact Jefferson Tools or Service Centre.

TROUBLESHOOTING

If errors occur, refer to the following chart:

	Possible Cause	Solution
E0	Plugged in while switch is on	- Switch heater off, then turn back on
E1	Low fuel level Photocell defective Combustion defective Ignition failure	- Fill the fuel - Change photocell - Clean fuel filter - Check spark plug
E2	Thermostat disconnected Thermostat defective	- Connect Thermostat - Replace Thermostat
E3	Heater overheating Sensor disconnected Sensor defective	- Turn off until cooled - Reconnect sensor - Replace sensor
E4	Blower Motor is stopped Blower Motor connection line broken When Blower Motor Fan is restrained	- Check wire connection - Contact service centre
Lo	Below 9°C	- Normal
Cn	Temp 45 - 59°C	- Normal



WARNING

1. Use only good quality Kerosene or Diesel.
2. **DO NOT** place any explosive material near heater.
3. **DO NOT** block rear guard
4. **DO NOT** block air duct.
5. Turn off the heater when refuelling or moving.
6. Safety distance from heater is 3 metres.
7. **DO NOT** try to disassemble, repair or modify the heater.
8. **DO NOT** let children touch the heater.
9. **DO NOT** move heater when it is turned on.

PARTS LIST

#	Description	#	Description
1	Fuel Tank	36	Burner Bracket
2	Fuel filter	37	Burner Head Gasket
3-1	Float Sensor	38	In Diffusion
3-2	Float Sensor Packing	39	Control Base
3-3	Fuel Pipe	40	Power Cord
3-4	Return Pipe	41	Cord Bush
3-5	Pipe Packing	42	Return Hose Joint Pipe
3-6	Nut	43	Photocell
3-7	Inlet Fuel Fiter	44	Photocell Bracket
4	Flexible hose	45	Blower Casing
5	Elbow Flexible hose	46	Inlet
5-1	Flexible hose Clamp	47	Blower Motor
6	Fuel Cap	48	Blower Fan
7	Fuel Cap Inner Packing	49	Thermostat
8	Fuel Cap Packing	50	Thermostat Wire
9	Fuel Gauge	51	Igniter
10	Fuel Gauge Packing	52	Electronic Pump
11	Tank Support -L	53	Electronic Pump Pipe
12	Tank Support -R	54	Fuel Filter
13	Cone Body	55	Return Hose
14	Visor Bracket	56	Electronic Pump Base
15	Sticker Bracket	57	Spacer Support
16	Out Diffusion Gasket	58	Main P.C.B
17	Out Diffusion	59	Sub P.C.B &Wire
18	Insulator Body	60	P.C.B Wire
19	Heat Plate	61	Tip Over Switch
20	Cone Body Holder	62	Tip Over Switch Wire
21	Umbrella Bracket	63	Back Cover
22	Bolt	64	Name Plate
23	Nut	65	Power Switch
24	Umbrella	66	Power Switch Wire
25	Rotate ADJ. Handle	67	Spark Plug Cover
26	Support Pipe	68	Handle
27	Guard Bracket	69	Wheel Support Frame
28	Guard	70	Wheel Axle
29	Visor	71	Wheel
29-1	Heater Interception	72	Washer
30	Burner Bracket Gasket	73	Pin
31	Burner Head	74	Pipe Washer
32	Nozzle	75	Pressure Sensor
33	Burner Head Blade	76	Venturi
34	Nipple	77	Pressure Sensor Hose
34-1	Dump Solenoid	78	Thermistor
35	Spark Plug		

Energy Related Product (ErP) Directive Information

Model:	JEFHTRAD125TC - Infrared Direct Oil Heater		
Indirect Heating Functionality:	No		
Direct Heat Output:	125,000BTU / 36.6kW		
Fuel:	Paraffin / Diesel / Kerosene		Space Heating Emissions:
			Nox
Select Fuel Type:	Liquid		49 mg/kWhinput (GCV)

Item	Symbol	Value	Unit	Item	Symbol	Value	Unit
Heat Output				Useful efficiency (NCV)			
Nominal heat output	Pnom	32.2	kW	Useful efficiency at nominal heat output	$\eta_{th,nom}$	93.6	%
Minimum heat output (indicative)	Pmin	N/A	kW	Useful efficiency at minimum heat output (indicative)	$\eta_{th,min}$	N/A	%
Auxiliary electricity consumption				Type of heat output/room temperature control (select one)			
At nominal heat output	elmax	0.05	kW	single stage heat output, no room temperature control			No
At minimum heat output	elmin	0.05	kW	two or more manual stages, no room temperature control			No
In standby mode	elSB	N/A	kW	with mechanic thermostat room temperature control			No
				with electronic room temperature control			Yes
				with electronic room temperature control plus day timer			No
				with electronic room temperature control plus week timer			No
				Other control options (multiple selections possible)			No
				room temperature control, with presence detection			No
				room temperature control, with open window detection			No
				with distance control option			No
				with adaptive start control			No
				with working time limitation			No
				with black bulb sensor			No
Permanent pilot flame power requirement							
Pilot flame power requirement (if applicable)	Ppilot	N/A	kW				
Contact Details	<p>Jefferson Professional Tools & Equipment 24 Lisgorgan Lane, Upperlands, BT46 5TE</p> <p>Tel: +44 (0)1244 646 048 (UK) / +353 (0)1473 0300 (ROI) Email: info@jeffersonstools.com</p> <p>Website: www.jeffersonstools.com</p>						

ENVIRONMENTAL PROTECTION



Recycle any packaging and unwanted materials instead of disposing of them as waste. All tools, accessories and packaging should be sorted, taken to a recycling centre and disposed of in a manner which is compatible with the environment. When the product becomes completely unserviceable, reaches the end of its working life and requires disposal, drain off any fluids (if applicable) into approved containers and dispose of the product and the fluids according to local regulations.

WASTE ELECTRICAL AND ELECTRONIC EQUIPMENT (WEEE)



Information on Disposal for Users of Waste Electrical & Electronic Equipment:

This symbol on the product(s) and / or accompanying documents means that used electrical and electronic products should not be mixed with general household waste. For proper treatment, recovery and recycling, please take this product(s) to designated collection points where it will be accepted free of charge.

For private households:

Dispose of this product at the end of its working life and in compliance with the EU Directive on Waste Electrical and Electronic Equipment (WEEE). Contact your local solid waste authority for recycling information for this equipment. Disposing of this product correctly will help save valuable resources and prevent any potential negative effects on human health and the environment, which could otherwise arise from inappropriate waste handling. Please contact your local authority for further details of your nearest designated collection point. Penalties may be applicable for incorrect disposal of this waste, in accordance with your national legislation.

For business users in the European Union:

If you wish to discard electrical and electronic equipment, please contact your dealer or supplier for further information.

Information on Disposal in other Countries outside the European Union:

This symbol is only valid in the European Union. If you wish to discard this product please contact your local authorities or dealer and ask for the correct method of disposal.

WARRANTY

Jefferson Professional Tools & Equipment, or hereafter "Jefferson" warrants its customers that its products will be free of defects in workmanship or material. Jefferson shall, upon suitable notification, correct any defects, by repair or replacement, of any parts or components of this product that are determined by Jefferson to be faulty or defective. This warranty is void if the equipment has been subjected to improper installation, storage, alteration, abnormal operations, improper care, service or repair. Unless otherwise stated, the guarantee is **12 months** from purchase date, proof of which is required for any claim. Full details of how you can register and activate your warranty as well as instructions on how to make a warranty claim are available on our website: warranty@jeffersonstools.com. For any further information relating to Jefferson warranty cover please call **+44 (0)1244 646 048 (UK)** or **+353 (0)1473 0300 (ROI)**.

EU DECLARATION OF CONFORMITY

We, Jefferson Professional Tools & Equipment, as the authorised European Community representative of the manufacturer, declare that this equipment conforms to the requirements of the following:

Machinery Directive 2006/42/EC
Low Voltage Directive 2014/35/EU
EMC Directive 2014/30/EU
EN ISO 12100:2010, EN 60204-1:2006/A1:2009, EN 60335-1:2012/A11:2014, EN 61000-3-2:2014
EN 61000-3-3:2013, EN 61000-6-2:2005, EN 61000-6-4:2007/A1:2011, EN 62233:2008

Commission Regulation (EU) 2015/1188 implementing Directive 2009/125/EC of the European Parliament and of the Council with regard to ecodesign requirements for local space heaters Annex II: Eco Design Directive: 2009/125/EC Annex I, (EU) 2015 / 1188, (EU) 2015 / 1186

Commission Delegated Regulation (EU) 2015/1186 EN 13842:2004 - Oil fired forced convection air heaters. Stationary and transportable for space heating

European Directive 2011/65/EU concerning RoHS and additionally according to Directive (EU) 2015/863 to amend Annex II with four additional substances: Pb, Hg, Cd, Cr(VI), PBBs and PBDEs could not be detected over the limit defined by the European Directive (EU) 2015/863. DEHP, BBP, DPB and DIB could not be detected over the limit defined by the European Directive (EU) 2015/863.

UK DECLARATION OF CONFORMITY

We, Jefferson Professional Tools & Equipment, as the authorised UK representative of the manufacturer, declare that this equipment conforms to the requirements of the following:

EN 62321-1:2013
EN 62321-2:2014
EN 62321-3-1:2014
EN 62321-4:2014/A1:2017

Signed by: Stephen McIntyre (Operations Director) Date: 30.05.2022

Name and address of manufacturer or authorised representative:

Jefferson Professional Tools & Equipment,
24 Lisgorgan Lane, Upperlands, BT46 5TE

T: +44 (0)1244 646 048 (UK)
T: +353 (0)1473 0300 (ROI)
E: info@jeffersonstools.com
W: www.jeffersonstools.com



IMPORTANT! SAFETY FIRST!

Before attempting to use this product please read all the safety precautions and operating instructions outlined in this manual to reduce the risk of fire, electric shock or personal injury.

Jefferson Professional Tools & Equipment

24 Lisgorgan Lane,
Upperlands,
BT46 5TE

Tel: +44 (0)1244 646 048 (UK) / +353 (0)1473 0300 (ROI)

Email: info@jeffersonstools.com

www.jeffersonstools.com