

# RoadRunner RS5 Scooter

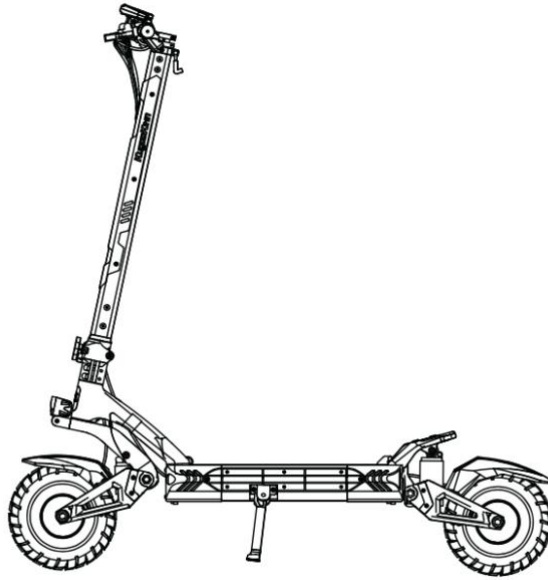

Pictures in this manual are for reference only. Please read the full instruction manual before using your Scooter.

For instructional videos on how to: get your scooter ready to ride, maintain your scooter, and repair your scooter, scan this QR code with your camera phone and browse dozens of videos.



Contents

---

<b>2. Scooter Components</b>	4
<b>3. Scooter Specs</b>	5
<b>4. Product Display</b>	6
<b>5. Charging the Scooter</b>	7
<b>6. Battery and Charger Information</b>	8
<b>7. Handlebar Controls and Instruments</b>	8
<b>9. Parameter Settings (P Settings)</b>	11
<b>10. Riding Instructions</b>	12
<b>11. Operating instructions</b>	13
<b>12. Safety Instructions</b>	15
<b>13. Maintenance</b>	16
<b>14. Error codes</b>	17
<b>15. Troubleshooting common errors</b>	18
<b>16. Unfolding the Scooter</b>	19
<b>18. Folding the Scooter</b>	20
<b>19. How to Carry Your Scooter</b>	21
<b>20. Changing the combination lock password</b>	21
<b>22. Warranty Policy</b>	21

# 1. Scooter and Accessories

## Scooter

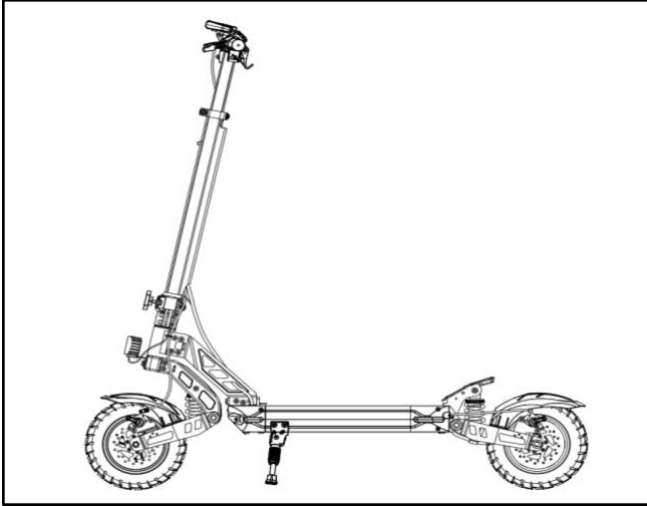

## Accessories

1. Owner's Manual
2. Charger
3. Multi-tool

# 2. Scooter Components

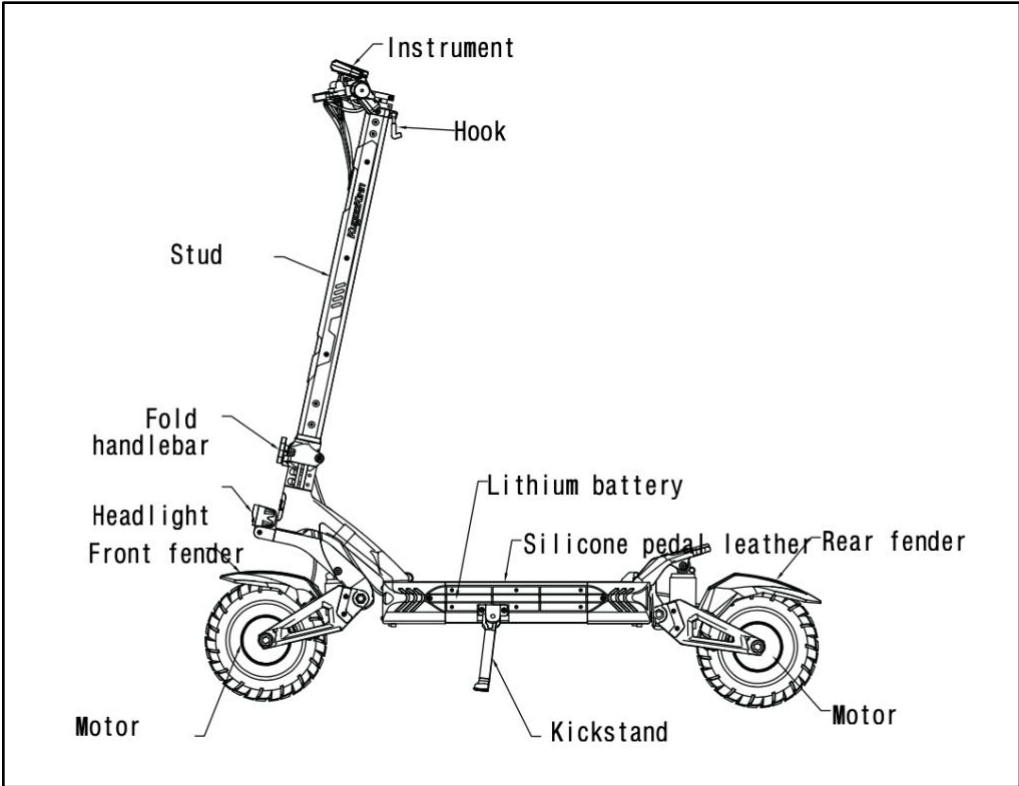

### 3. Scooter Specs

Product name	RoadRunner RS5 Electric Scooter
Product model	RS5
Folded Dimensions	51" (l) x 25" (w) x 24" (h)
Unfolded Dimensions	51" (l) x 24" (w) x 51" (h)
Net weight	79 lbs
Max load	330 lbs
Max speed	42 MPH (depending on environment, climb, weight and driving habits)
Range: RS5 RS5+	45 miles 58 miles (depending on environment, climb, speed, weight, driving habits)
Max climb	20° incline
Suspension	Front and Rear Hydraulic Spring Shocks
Tire	10" pneumatic tubeless air
IP Rating	IP54
Brake system	Electric & hydraulic disc brake
LED display	Headlights, cruise, brake, gear, and range indicator
Light system	LED high headlight
Lithium battery	52V 23.2AH (RS5) 52V 28AH LG (RS5+)
Charging time	2A battery charger 9-10 hours, (2) 2A chargers 4-5 hours

# 4. Product Display

Scooter unfolded



Scooter folded

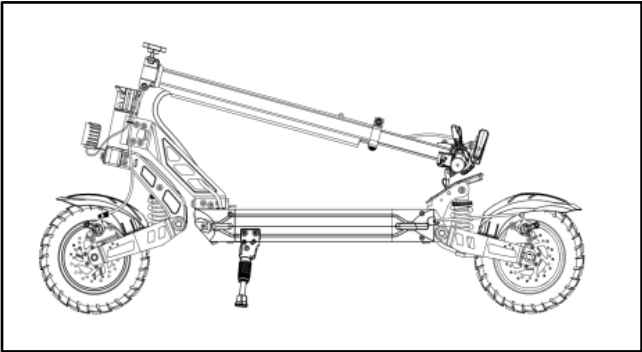

## 5. Charging the Scooter

1. Plug the charger into a power supply (wall outlet, power strip, etc.)
2. Open the waterproof cover on the charging port, then plug the charger into the charging port.
3. A red light means the Scooter is charging; green means it is fully charged.
4. Cover the charging port once the charger is removed.

## 6. Battery and Charger Information

Every RoadRunner RS5 Scooter is equipped with a dedicated lithium battery and a dedicated smart charger. Please do not use any other charger or battery with your scooter, and do not use your dedicated charger with any other product. We are not responsible for any damage incurred due to misuse of your charger.

1. **Battery:** The lithium battery provided by RoadRunner Scooters can be charged up to 600 times with no change in capacity; over 600 uses the battery's capacity will drop to 80%. Over 1000 uses, the battery may be unsafe to use.

**Maximum Voltage for full battery charge:** 58.8 V

**Minimum Voltage before battery dies:** 42.0 V

**WARNING: NEVER LEAVE SCOOTER UNATTENDED WHILE  
BATTERY IS CHARGING!**

2. **Charger:** The smart charger included with your RS5 scooter automatically stops charging and the light turns green when your scooter reaches 100%, which means it is fully charged. The battery should be fully charged in 9-10 hours (4-5 hours with 2 chargers). If your battery will not charge, please contact RoadRunner Scooters for help. If your battery is damaged due to weather or human interaction, it is not covered under our warranty.



## 7. Handlebar Controls and Instruments

1. Handlebar
2. Left Brake Handle
3. Handlebar
4. LCD Display
5. Right Brake Handle
6. Headlight
7. Electric Lock
8. Power (on/off) Button / Gear Switch Button

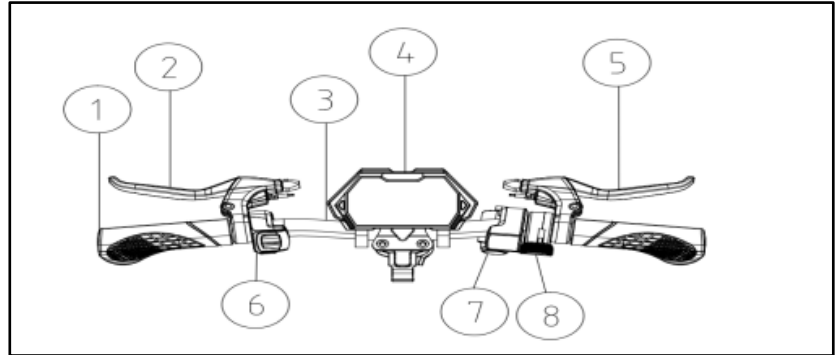

# 8. LCD Display

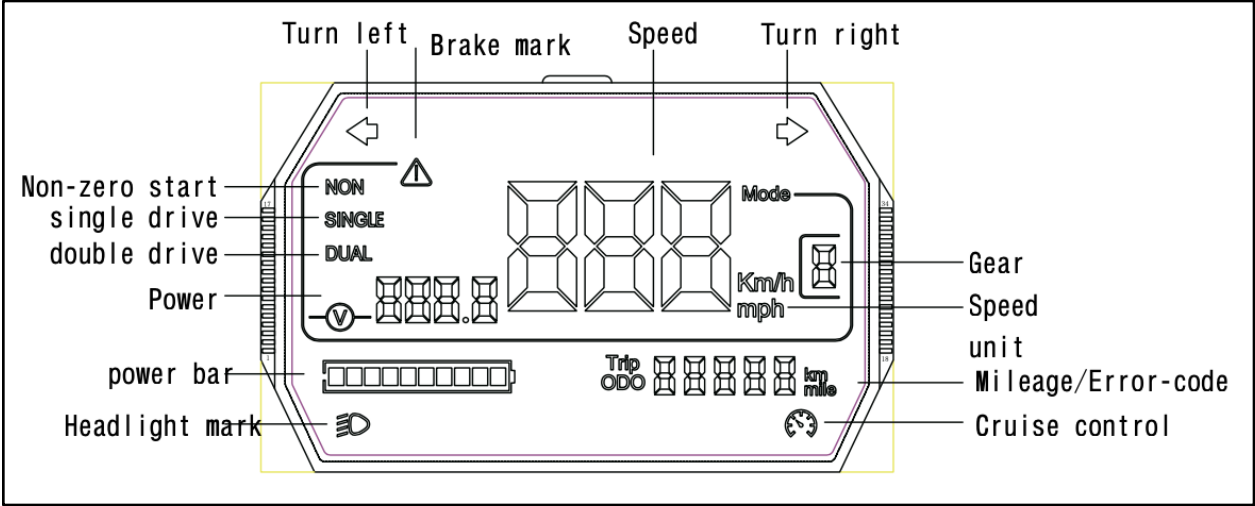

## 9. Parameter Settings (P-Settings)

To make changes to any P-settings, press the power button quickly three times in row. Once the selected values begin flashing, quickly press the power button just once to cycle through the options. Press the power button to exit the current P settings or to advance to the next P-setting. P-settings will automatically exit if there is no activity for 8 seconds.

Example: to modify KM vs. miles, press the power button quickly three times in row to enter P1. Once the selection flashes, press the power button once to select 0 (KM) and once more to select 1 (miles). Once you've made your selection, press the power button to proceed to the P2 setting.

P2	Voltage level setting (36V, 48V, 52V, 60V, 72V); <b>default 52V</b>
P3	Wheel diameter, in inches default <b>10</b>
P4	# of magnetic poles for speed measurement, 1-100 <b>default is 30.</b>
P5	Cruise selection (0 means no cruise, 1 means cruising) <b>default 0</b>
P1	KM/Miles setting; <b>default is miles</b>
P6	Zero startup (0) vs. non-zero startup (1) settings. When powering on, no icon will be displayed if zero startup; the display will show "NON" if zero startup. In non-zero startup mode, you will need to manually bring the scooter to 3 MPH and press the accelerator to start. <b>default 0</b>
P7	Speed limit setting, 1-100% default <b>100</b>
P8	Sleep time setting, 1-60 minutes default <b>5</b>
PA	Start strength setting, 1-5 <b>default 2</b>
PB	Brake strength setting 1-5 (1 least stopping power, 5 strongest) <b>default 1</b>

## 10. Riding Instructions

1. Choose an open space without obstacles or uneven surfaces.
2. Unfold your scooter according to section 7 and wear protective gear.
3. Turn your key to the right to turn on the scooter.
4. Begin with one foot on the deck and one foot on the road.
5. Once you're riding comfortably, put both feet on the deck. Apply more pressure to the throttle to increase your speed.

**In case of an emergency, use both brake handles to brake quickly.**

# 11. Operating instructions

**Power on/off:** Power on/off

- a. Turn your key to the right to turn on, turn your key to the left to turn off.
- b. Long press the power button to turn the LCD display on/off.
- c. Press once quickly to switch gears (default is gear 1).

**Gear setting:** Press the button located on the throttle to switch gears. 1st gear: ECO, 2nd gear: D, 3rd gear: S

<i>First gear</i>	Second gear	Third gear
Slow Speed (ECO)	Medium Speed (D)	Fast Speed (S)

**Kick Start Mode:** The throttle system will work once the scooter reaches 3 MPH. Press the throttle smoothly to accelerate. Refer to P-settings on how to engage.

**Brake control:** Press the brake using your left hand to stop. A firmer grip will lead to faster braking; for the fastest braking, use both hands to brake at the same time.

**Headlights:** When the scooter is powered on, push the headlight button forward to turn on headlights, taillights, and sidelights. Push the light button back to turn off the lights.

**Cruise control:** When cruise control is turned on, it will automatically be activated when you reach the set speed. Release the thumb accelerator and the scooter will automatically move at the set speed. To cancel the cruise control, pull either brake lever and cruise control will automatically turn off.

**Take off on Scooter:** With one foot on the scooter and one foot on the road, slowly press the throttle to accelerate. Once you've ridden a short distance, put both feet on the deck to continue riding.

## 12. Safety Instructions

Please read the following carefully before use.

- This scooter is for use by one adult rider at a time.
- When riding, please wear safety gear including a helmet.
- Always keep both hands and both feet on your scooter while riding.
- Do not ride your scooter anywhere unsafe or illegal.
- Practice riding in an open space first, and only ride on the road once you're comfortable and competent.
- If you ride at night, please turn on your lights.
- Do not use your scooter in temperatures below 0 degrees Fahrenheit
- Please ride slowly if you encounter an uneven surface or poor road conditions.
- Do not ride on a slippery surface (i.e., ice and oil)
- Do not exceed the weight limit that the scooter can bear.
- Avoid using your scooter in extremely high or low temperatures, and do not store it near flammable items.
- Do not immerse your scooter in water higher than 1/2" to avoid electrical damage.
- Avoid riding in extreme weather conditions such as rain, snow, and high winds.
- Take care to avoid potholes.
- Always ride in accordance with local traffic laws and regulations.
- Recommended age is 16 years or older to ride.

# 13. Maintenance

## 1. Lubricant

- a. Every six months, add a small amount of white grease or lubricant to the main joint.
- b. You should check your scooter regularly for loose screws and tighten them.

## 2. Battery

- a. Be sure to fully charge your scooter's battery before your first ride.
- b. Make sure you change your battery every three months at minimum to avoid damage.

## 3. Storage and daily care

- a. Do not store your scooter in direct hot sun or in a damp area.
- b. Keep your scooter clean to avoid damage.



## 14. Error codes

E-001	Rear motor haul error - swap front and rear motor heads. If code still appears, replace the controller. If it does not appear, replace the motor.
E-003	Controller error - change the controller and try again
E-005	Voltage error - battery is low; charge the battery and try again
E-006	Receiver error - replace instrument/controller and try again
E-007	Sending error - replace instrument/controller and try again
E-009	Controller temperature error - Controller's temperature is too high
E-011	Front motor haul error - swap front and rear motor heads. If code still appears, replace the controller. If it does not appear, replace the motor.
E-013	Secondary controller failure - Change the controller and try again
E-017	Sub-controller receiving failure - replace instrument/controller and try again

# 15. Troubleshooting common errors

## 1. Display appears black

- a. The display may overheat from direct sunlight.
- b. Place the scooter in the dark for a while and try again in 30 minutes

## 2. Display does not show an accurate reading

- a. Parameters may be set incorrectly.
- b. Try resetting options.

## 3. Display appears opaque or shows discontinuous values

- a. Maybe due to a poor contact connection or low battery.
- b. Restart your scooter or contact RoadRunner Support.

## 4. Complete diagnosis

- a. Power on
- b. Check power on the display screen
- c. Ensure brakes are in place
- d. Ensure all jacks and connectors are connected properly

Please contact RoadRunner Support at [support@roadrunnerscooters.com](mailto:support@roadrunnerscooters.com) if you need further assistance.

## 16. Unfolding the Scooter

1. Press the clip with one hand while pulling up on the upright tube with the other.

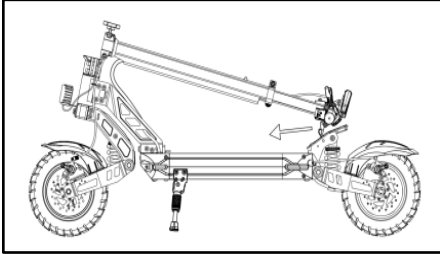

2. Pull the stem upright.

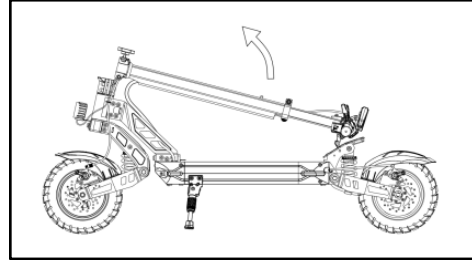

3. Once the stem is up, pull the folding clip.

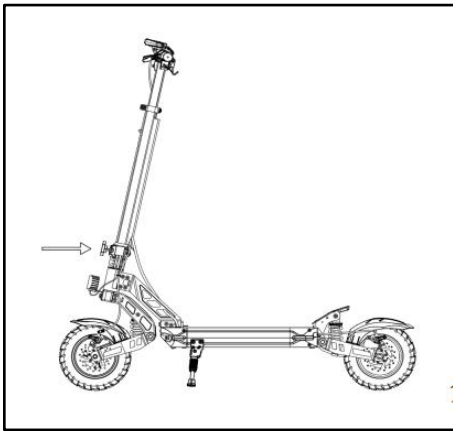

4. Lock the folding clip.



# 18. Folding the Scooter

Note: For your safety, be sure your Scooter is powered off before folding.

1. Pull the safety catch upward.

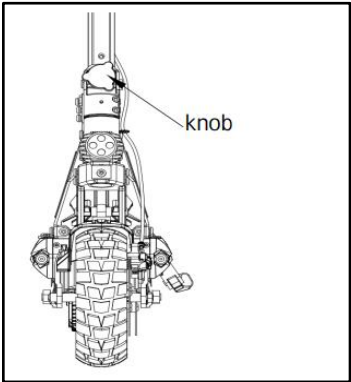

2. Pull the folding buckle outward.

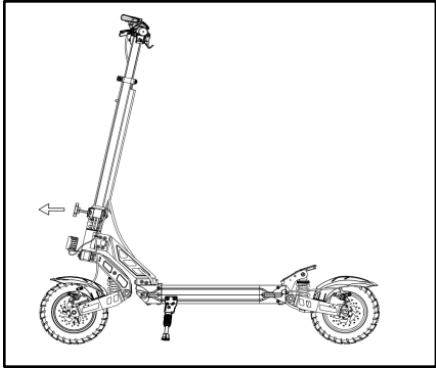

3. Push the stem down toward the deck.

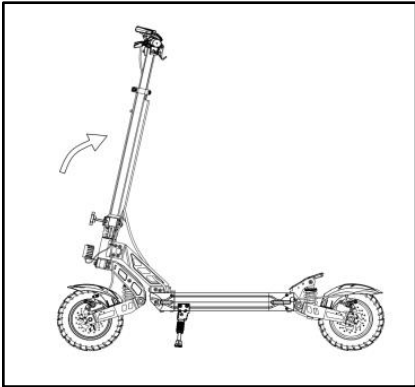

4. Push the lever hook into the hook slot.

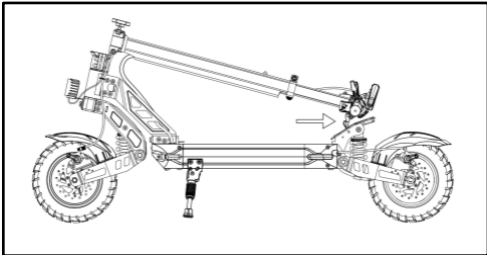

# 19. How to Carry Your Scooter

When folded up, your scooter can be carried with one or two hands.

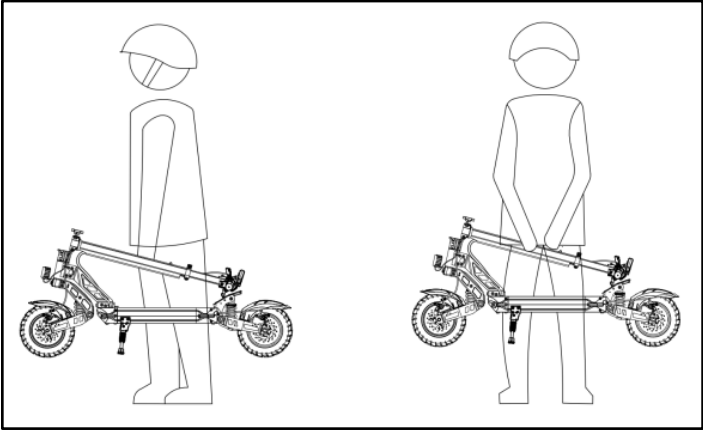

# 20. Changing the combination lock password

The factory setting password is 0 0 0. Make sure the tick marks are aligned to 0 0 0 before resetting your password.

To reset, use a small sharp object to press the reset button located inside the hole, set your new password, then release the button.

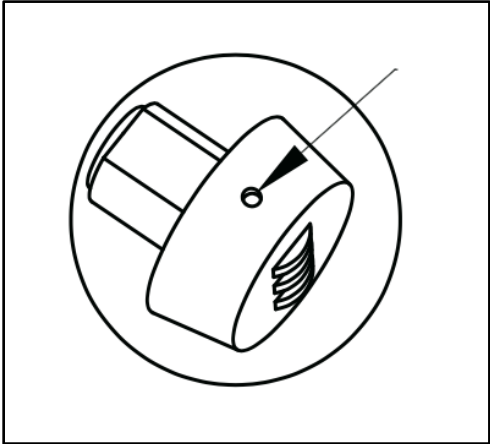

## 22. Warranty Policy

The RoadRunner RS5 Scooter comes with a one-year limited warranty. For full warranty information scan this QR code with your camera phone or visit our website at:

<https://roadrunnerscooters.com/pages/warranty-policy-1>



Words and trademarks are trademarks or registered trademarks of RoadRunner Scooters, LLC. Other companies mentioned, products or service names may be trademarks or registered trademarks of their respective owners.

This enterprise belongs to RoadRunner Scooters, LLC all rights reserved.