

INSTALLATION INSTRUCTIONS FOR LED FLAT LINEAR HIGH BAY FIXTURE



MODEL: CL-PHBXX-XXXXX-XXXX

Thank you for purchasing CLEANLIFE® LED Lighting Fixtures.

PLEASE READ CAREFULLY BEFORE INSTALLING LIGHT FIXTURE.
Save these instructions, as you may need them at a later date.

WARNINGS:

READ AND FOLLOW ALL SAFETY INSTRUCTIONS CAREFULLY:

- Turn power off before inspection, installation or removal. Use all necessary precautions while performing this procedure.
- Consult a qualified electrician to ensure correct branch circuit conductor. Min 90°C supply conductors.
- Properly ground electrical enclosure. IT IS IMPERATIVE THAT THE OUTLET BOX BE PROPERLY GROUNDED.
- DO NOT REVERSE THE HOT AND NEUTRAL CONNECTIONS, OTHERWISE SAFETY WILL BE COMPROMISED
- This Integrated LED figure has no lamp/bulb to replace.

GENERAL: All electrical connections must be in accordance with local and National Electrical Code (N.E.C.) standards. If you are unfamiliar with proper electrical wiring connections, contact and obtain the services of a qualified electrician. Use UL or IEC approved wire only for input/output connections.

DIMMING: This product is compatible with 0~10V dimmers only!
*Speak to your CLEANLIFE® sales representative for more information on 0~10V dimmers.

INCLUDED ACCESSORIES (FOR SUSPENSION MOUNT INSTALLATION ONLY):

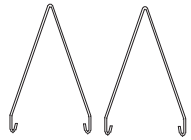

2 X SUSPENSION HOOKS

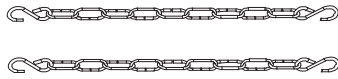

2 X SUSPENSION CHAINS

ELECTRICAL SCHEMATIC DIAGRAM:

STANDARD LED DRIVER (NON DIMMABLE)

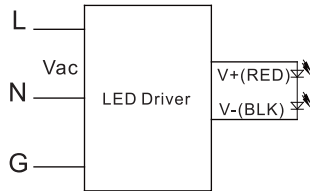

LED DRIVER WITH 0~10VDC DIMMING WIRES

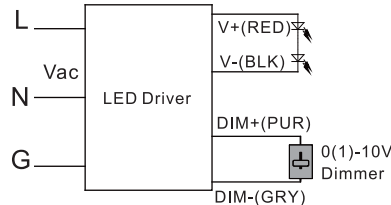

SUSPENSION MOUNT INSTALLATION:

1. SHUT OFF MAIN ELECTRICAL SUPPLY FROM THE MAIN FUSE BOX/CIRCUIT BREAKER!
2. Remove fixture and mounting components from the box, and make sure that no parts are missing by referencing the illustrations in the installation instructions.
3. Attach the suspension hooks to the driver box on the back of the lamp. (REFER TO DIAGRAMS)
4. Attach the suspension chain to "V" part if the suspension hook, and then to the mounting point on the ceiling. (REFER TO DIAGRAMS)
5. Make the wiring connections:
Connect the Line (typically black wire), Neutral (typically white wire), and Ground (typically green wire) to the corresponding wires in the J-Box.
6. **OPTIONAL:**
If the fixture is equipped with 0~10VDC dimming wires, connect the positive wire (typically purple) and the negative wire (typically grey) to the corresponding wires on the dimmer.
DIMMER NOT INCLUDED
7. Restore power at fuse box/circuit breaker. Confirm fixture is operating properly.
8. Installation complete.

SUSPENSION MOUNT DIAGRAMS:

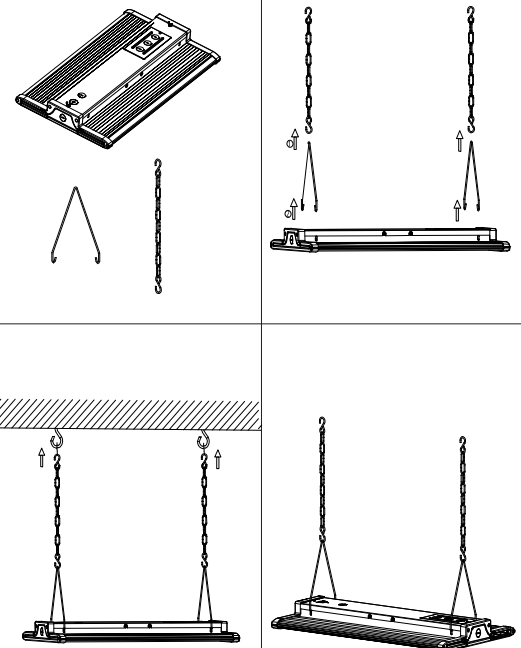

INSTALLATION CONTINUED ON REVERSE →

THREADED PIPE INSTALLATION (ACCESSORIES SOLD SEPARATELY):

1. SHUT OFF MAIN ELECTRICAL SUPPLY FROM THE MAIN FUSE BOX/CIRCUIT BREAKER!
2. Remove fixture and mounting components from the box, and make sure that no parts are missing by referencing the diagrams.
3. Attach the round ceiling base to the desired mounting area using the 3 screws provided. (REFER TO DIAGRAMS)
4. Screw the threaded pipe into the ceiling base. (REFER TO DIAGRAMS)
5. Thread the bolt onto the other end of the threaded pipe. (REFER TO DIAGRAMS)
6. Attach the I-Type bracket to the threaded pipe. Slide the washer, then lock the washer, and then tighten the other bolt onto the threaded pipe to secure the I-Type bracket to the threaded pipe. (REFER TO DIAGRAMS)
7. Use the 4 screws on the driver box to attach the I-Type bracket to the driver box. (REFER TO DIAGRAMS)
8. *Make the wiring connections:*
Connect the Line (typically black wire), Neutral (typically white wire), and Ground (typically green wire) to the corresponding wires in the J-Box.
9. **OPTIONAL:**
If the fixture is equipped with 0~10VDC dimming wires, connect the positive wire (typically purple) and the negative wire (typically grey) to the corresponding wires on the dimmer.
DIMMER NOT INCLUDED
10. Restore power at fuse box/circuit breaker. Confirm fixture is operating properly.
11. Installation complete.

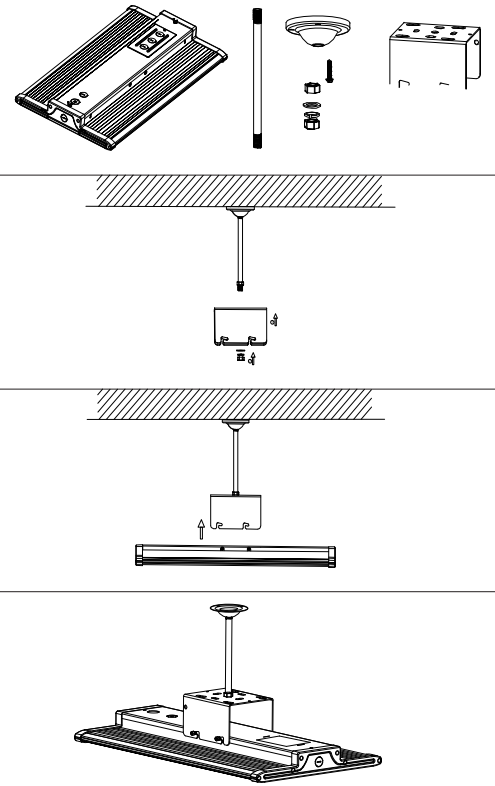
THREADED PIPE DIAGRAMS:**CEILING MOUNT INSTALLATION (ACCESSORIES SOLD SEPARATELY):**

1. SHUT OFF MAIN ELECTRICAL SUPPLY FROM THE MAIN FUSE BOX/CIRCUIT BREAKER!
2. Remove fixture and mounting components from the box, and make sure that no parts are missing by referencing the illustrations in the installation instructions.
3. Attach the I-Type bracket to desired ceiling location with the 4 provided screws. (REFER TO DIAGRAMS)
4. Use the 4 screws on the driver box to attach the I-Type bracket to the driver box. (REFER TO DIAGRAMS)
5. *Make the wiring connections:*
Connect the Line (typically black wire), Neutral (typically white wire), and Ground (typically green wire) to the corresponding wires in the J-Box.
6. **OPTIONAL:**
If the fixture is equipped with 0~10VDC dimming wires, connect the positive wire (typically purple) and the negative wire (typically grey) to the corresponding wires on the dimmer.
DIMMER NOT INCLUDED
7. Restore power at fuse box/circuit breaker. Confirm fixture is operating properly.
8. Installation complete.

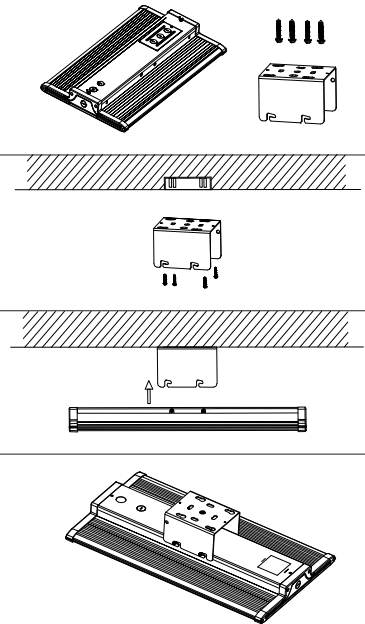
CEILING MOUNT DIAGRAMS**TROUBLE SHOOTING:**

- Check that line voltage at fixture is correct.
- Ensure that there is voltage at fixture wires.
If there is no voltage, then check all connections.
- Check that fixture is grounded properly.

If fixture does not light:

- Check switch to ensure that there are no defects.
- Check fuse box/circuit breaker for trips, then check wiring connections.

CLEANING AND MAINTENANCE:

- CAUTION: Ensure fixture temperature is cool enough to touch. DO NOT clean or perform maintenance while fixture is energized.
- Clean lens and fixture with a non-abrasive cleaning solution.
 - Do not open fixture to clean LED. Do not touch the LED
 - Do not spray liquid directly on to LED, LED driver or wiring.

5-YEAR LIMITED WARRANTY:

LIMITED WARRANTY: CLEANLIFE® LED Light Fixtures are warranted to be free and clear of defects in materials and workmanship for a period of five years from the date of purchase. This warranty covers defects in manufacturing discovered while using the product as recommended by the manufacturer and does not apply to failures caused by acts of God or as a result of any abuse, misuse, abnormal use, or use in violation of any applicable standard, code, or instructions for use in installations. If a CLEANLIFE® LED Light Fixture fails due to a defect covered by this warranty, CLEANLIFE® will, at its option, either replace the product or provide a credit equal to the current price CLEANLIFE® charges for the product. To make a warranty claim, retain the failed products and notify a CLEANLIFE® sales representative in writing within thirty (30) days of the failure.



CLEANLIFE® LED
2400 Superior Avenue, Suite 207
Cleveland, Ohio 44114
www.cleanlife.com

Technical Support Information
1-800-316-2532
Hours: 8:30am - 5:00pm Est (Monday - Friday)