

KeeHatch® Roof Hatch Railing  
 INSTALLATION  
 Model RHSR-FB 3054 (right exit  
 shown, left exit reversed)

877-723-3766 for assistance

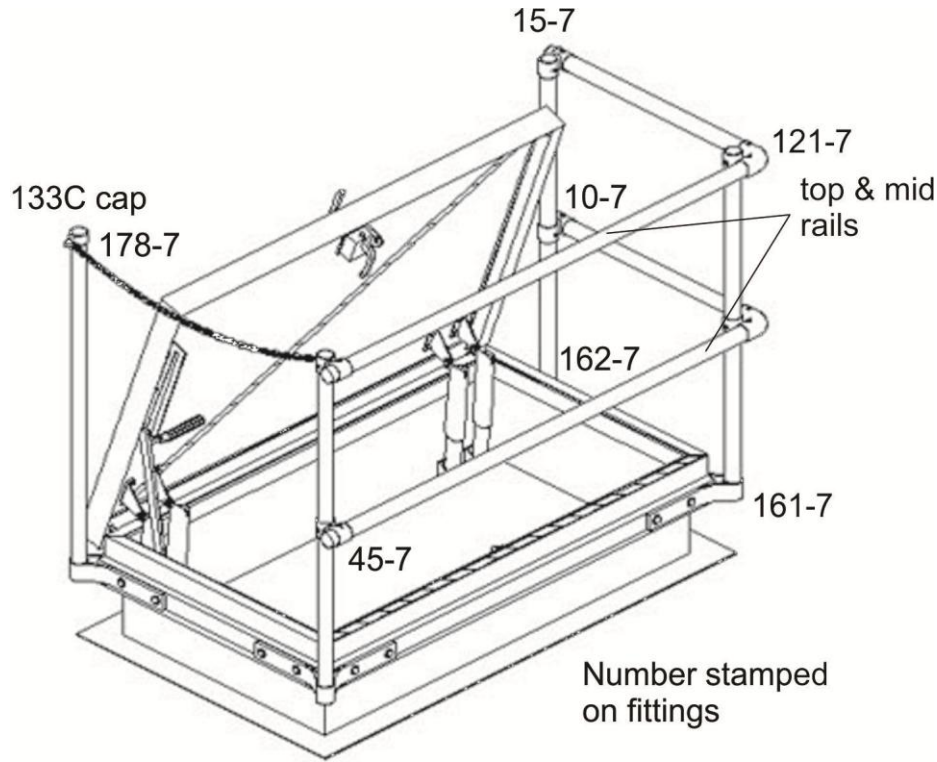

<u>Kee Klamp®</u>							
<u>#Q</u>	<u>fittings</u>	<u>#Q</u>	<u>Pipe</u>	<u>Size</u>	<u>#Q</u>	<u>Item</u>	<u>Size</u>
1	10-7	1	Post	40 1/8"	1	Chain & "S" Hook Quick Link	60"
1	15-7	3	Posts	42 3/4"	14	3/8" x 2 1/2" Bolts	
2	45-7	2	Rails	36"	14	3/8" x 1 1/4" Bolts	
5	133C	2	Rails	66"	14	Nuts	
2	121-7				14	Fender washers	
2	178-7				14	SAE flat washers	
3	161-7				1	Product Label	
1	162-7				1	Warranty Card	

<b>Tools Needed Using RailingReady® Roof Hatches</b>	<b>Tools Using Non-RailingReady® Roof Hatches</b>
2 wrenches to tighten nuts torque wrench level hacksaw or sawzall to cut off bolts and excess pipe 5/16" hex key to tighten Kee Klamp® set screws exterior caulk and gun (roofing mfg. approved) bolt cutter to remove excess chain	2 wrenches to tighten nuts torque wrench marking device level drill or drill with 3/8" drill bit eye protection hacksaw or sawzall to cut off bolts and excess pipe file or grinder to remove burrs from bolt ends 5/16" hex key to tighten Kee Klamp® set screws exterior caulk and gun (roofing mfg. approved) bolt cutter to remove excess chain



877-723-3766 for assistance

We strongly recommend mounting all KeeHatch® Railing Systems on the counter flashing. 1 ¼" bolts are provided in kit to mount 161-7 & 162-7 brackets. With RailingReady® roof hatches, holes are pre-punched for brackets.

If mounting on the roof curb, abide by industry standards for mounting, fastening and sealing KeeHatch brackets.



Counter Flashing Mounting

**Mounting on Roof Hatch Curb When Counter Flashing Mounting is Not Possible**

Corner Post Installation

STEP 1	Insert 42 3/4" posts into Kee Klamp® fittings 161-7, tighten set screws. Place corner post assembly snugly against the corner of the roof curb, plumb and position approximately ¼" below counter flashing.
STEP 2	Mark 1st hole closest to hatch corner for 161-7 fitting, remove corner post assembly, drill marked hole through roof curb.
STEP 3	Place lock and fender washers over bolt and run bolt from inside roof curb through hole.
STEP 4	Apply approved sealant around holes on Kee Klamp fitting 161-7.
STEP 5	Replace corner post assembly over bolt, plumb and tighten nut snugly.
STEP 6	Drill 2nd hole on same bracket side from outside to inside while keeping corner post assembly in place and plumb.
STEP 7	Place lock and fender washers over bolt and run bolt from inside roof curb through 2nd hole. Tighten nut snugly.
STEP 8	Move to other side of 161-7 bracket, plumb safety railing from side to side and drill 3rd hole furthest from hatch corner.
STEP 9	Place lock and fender washers over bolt and run bolt from inside roof curb through 3rd hole. Tighten nut snugly. NOTE: Your corner post assembly should now be plumb from side to side and front to back.
STEP 10	Drill 4th hole from outside to inside, install lock and fender washers over bolt and run bolt from inside to outside. Tighten nut snugly.
STEP 11	Go back and tighten all nuts with torque wrench to 30 foot-pounds.

STEP 12	IMPORTANT: Cut off all bolt ends to the nuts. File or grind burrs on bolt ends. Caulk over nuts.
STEP 13	Check roof hatch for proper unobstructed closing.
Side Post Installation	
STEP 1	Insert 40 1/8" posts into Kee Klamp fittings 162-7, tighten set screws. Place side post assembly snugly against the roof curb 4" from back edge of curb, approximately 1/4" below cap flashing. Plumb side post assembly and mark one hole.
STEP 2	Remove side post assembly and drill hole through roof curb from outside to inside.
STEP 3	Apply approved sealant around holes on Kee Klamp fitting 162-7.
STEP 4	Place lock and fender washers over bolt and run bolt from inside roof curb through hole. Place side post assembly over bolt and tighten nut snugly.
STEP 5	Plumb side post assembly, drill remaining hole, place lock and fender washers over bolt and run bolt from inside roof curb through hole, tighten nut snugly. Caulk over nuts.
Top & Mid Rail Installation	
STEP 1	Slide KeeKlamp® fittings over corner post and side post assemblies as shown in diagram.
STEP 2	Install top & mid rail as shown in diagram keeping top rail at least 42" above roof surface and positioning mid rail halfway between the top rail and the top of the hatch curb. Level rails.
STEP 3	Cut off excess top and mid rails 1/2" from clamps. Install plastic pipe plugs 133C into tops of corner post assemblies and into top and mid rails.
STEP 4	Install fittings 178-7 with bevel facing down and positioned as per diagram. Install quick link through one 178-7 fittings and chain, tighten nut. Cut off excess chain links. Chain should be reasonably taut.
STEP 5	Install yellow product label in an obvious spot on the railing system.
STEP 6	Check roof hatch for proper unobstructed closing.
STEP 7	Fill out warranty registration card and return to manufacturer.
Other Railing Components	
Install other railing components according to diagram. Tighten all KeeKlamp set screws to 29 foot-pounds.	