



Safety Rail Source®

NEXTGEN POST-TYPE ROOF ANCHOR

SPECIFICATIONS

This fall arrest anchor is for single user in fall arrest or restraint, as part of an HLL system or for window washing tie-off. Do not connect more than one worker to an anchor. For use on a low sloped roof (4/12 pitch or less) unless otherwise specified by the manufacturer. A horizontal lifeline may be used with the Tie Down CRA's when designed by a qualified person. No more than two workers may tie off to a horizontal lifeline that is connected to a Tie Down CRA.

Compliance:

When used according to instruction specifications, this product meets or exceeds all applicable OSHA 1926 Subpart M, OSHA 1910, ANSI Z359.1-2007, and ANSI A10.32-2012 standards for fall protection.

Strength Rating:

Ultimate Strength Capacity : 5,000 lbs (any direction) Capacity: 420 lbs (Worker with Tools)

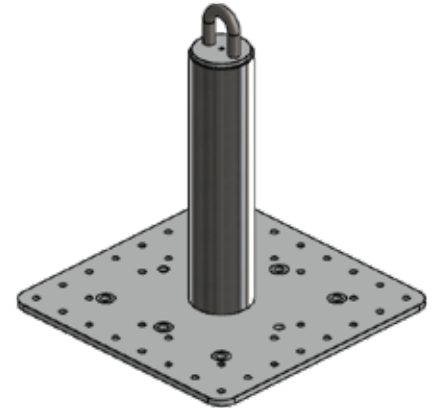

CRA-L16

8", 12", 18", 24" & 36" Risers
16"x 16" Square Base for Wood,
Metal, Concrete or Bolt On



CRA-LF

8", 12", 18", 24"
& 36" Risers
for Weld On
CRA's

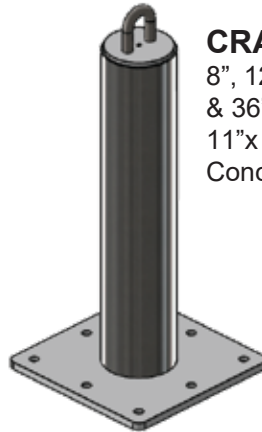

CRA-L11

8", 12", 18", 24"
& 36" Risers
11"x 11" Square Base for
Concrete or Bolt On



WARNING: This product can expose you to chemicals including Nickel, which is known to the State of California to cause cancer. For more information go to: www.P65Warnings.ca.gov



Online
CRA Instructions

Safety Information - Do not alter equipment. Do not misuse equipment.

Workplace conditions, including, but not limited to, flame, corrosive chemicals, electrical shock, sharp objects, machinery, abrasive substances, weather conditions, and uneven surfaces, must be assessed by a competent person before fall protection equipment is selected.

The analysis of the workplace must anticipate where workers will be performing their duties, the routes they will take to reach their work, and the potential and existing fall hazards they may be exposed to. Fall protection equipment must be chosen by a competent person. Selections must account for all potential hazardous workplace conditions. All fall protection equipment should be purchased new and in an unused condition.

A pre-planned rescue procedure in the case of a fall is required. The rescue plan must be project-specific. The rescue plan must allow for employees to rescue themselves, or provide an alternative means for their prompt rescue. Store rescue equipment in an easily accessible and clearly marked area.

Equipment subjected to forces of fall arrest must immediately be removed from use. Age, fitness, and health conditions can seriously affect the worker should a fall occur. Consult a doctor if there is any reason to doubt a user's ability to withstand and safely absorb fall arrest forces or perform set-up of equipment. Pregnant women and minors must not use this equipment. Physical harm may still occur even if fall safety equipment functions correctly. Sustained post-fall suspension may result in serious injury or death. Use trauma relief straps to reduce the effects of suspension trauma.



Made in USA

Safety Rail Source®

2570 Blvd of the Generals, Ste. 200

Norristown, PA 19403

(877) 723-3766

www.SafetyRailSource.com

Post-Type Roof Anchor Specifications

Material Specifications:

Loop Top Fixture: .625" Welded Loop
Finish: Hot Dip Galvanized

Loop Top Fixture:

Loop tops are designed for compatibility with snaphooks, carabiners, and SAS HLL fixtures.
DO NOT ATTACH MORE THAN ONE CONNECTOR TO A LOOP TOP AT ANY TIME

Riser	Sch	O.D.	Base Thickness	Base Size	Attachment Type	Number of Holes/Fasteners	Weight in lbs.	Tie Down Part #
8"	40	3"	3/8"	16" x 16"	Screw/Bolt On	40 Wood/Metal/8 Concrete	30.25	70861-L16
	40	3"	3/8"	11" x 11"	Bolt On	8 Concrete	16.5	70861-L11
	40	3"	N/A	N/A	Weld On	Field Weld - 5/16"	4.5	70861-LF
12"	40	3"	3/8"	16" x 16"	Screw/Bolt On	40 Wood/Metal/8 Concrete	33.0	70864-L16
	40	3"	3/8"	11" x 11"	Bolt On	8 Concrete	19.25	70864-L11
	40	3"	N/A	N/A	Weld On	Field Weld - 5/16"	7.0	70864-LF
18"	40	3"	3/8"	16" x 16"	Screw/Bolt On	40 Wood/Metal/8 Concrete	36.5	70870-L16
	40	3"	3/8"	11" x 11"	Bolt On	8 Concrete	22.75	70870-L11
	40	3"	N/A	N/A	Weld On	Field Weld - 5/16"	10.75	70870-LF
24"	40	4"	1/2"	16" x 16"	Bolt On	16 Concrete (8 required)	55.25	70873-L16
	40	4"	1/2"	11" x 11"	Bolt On	16 Concrete (8 required)	36.5	70873-L11
	40	4"	N/A	N/A	Weld On	Field Weld - 5/16"	20.25	70873-LF
36"	40	4"	5/8"	16" x 16"	Bolt On	16 Concrete (8 required)	74.75	70879-L16
	40	4"	5/8"	11" x 11"	Bolt On	16 Concrete (8 required)	51.25	70879-L11
	40	4"	N/A	N/A	Weld On	Field Weld - 5/16"	31.0	70879-LF

Swivel Cap								
Riser	Sch	O.D.	Base Thickness	Base Size	Attachment Type	Number of Holes/Fasteners	Weight in lbs.	Tie Down Part #
12"	40	3"	3/8"	16" x 16"	Screw/Bolt On	40 Wood/Metal/8 Concrete	33.0	70864-S16
	40	3"	3/8"	11" x 11"	Bolt On	8 Concrete	19.25	70864-S11
18"	40	3"	3/8"	16" x 16"	Screw/Bolt On	40 Wood/Metal/8 Concrete	36.5	70870-S16
	40	3"	3/8"	11" x 11"	Bolt On	8 Concrete	22.75	70870-S11

16" - 48 Hole Base Plate

Loop Cross Section: .625"
Tube: 4" Round
Base: 16" x 16" Square
Base Thickness: 3/8"
Strength Rating: 5,000 lbs

CRA -16" square base plates are fabricated with 40 - 3/8" holes for use with #14 screws and Headlok screws. Any one of 8 - 1/2" holes may be used for bolt or concrete embedment. Bolt holes are purposely oversized.

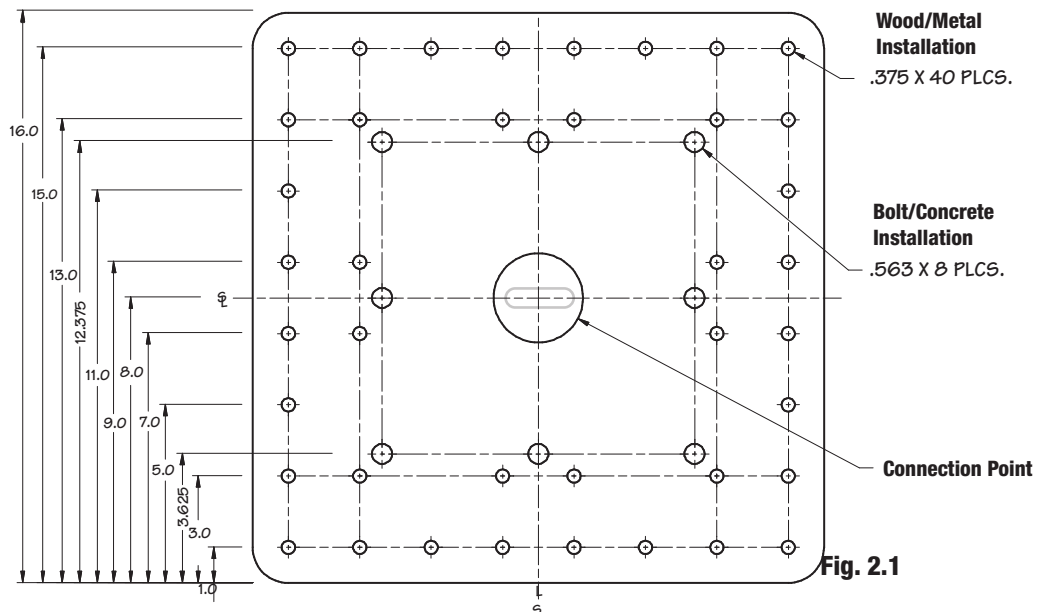

Post-Type Roof Anchor Specifications

16" - 16 Hole Base Plate

Loop Cross Section: .625"
 Tube: 4" Round
 Base: 16" x 16" Square
 Steel Thickness: .50"/.625"
 Strength Rating: 5,000 lbs.

CRA -16" square base plates are fabricated with 16 - 1/2" holes. Any one of 16 - 1/2" holes may be used for bolt or concrete embedment. Bolt holes are purposely oversized.

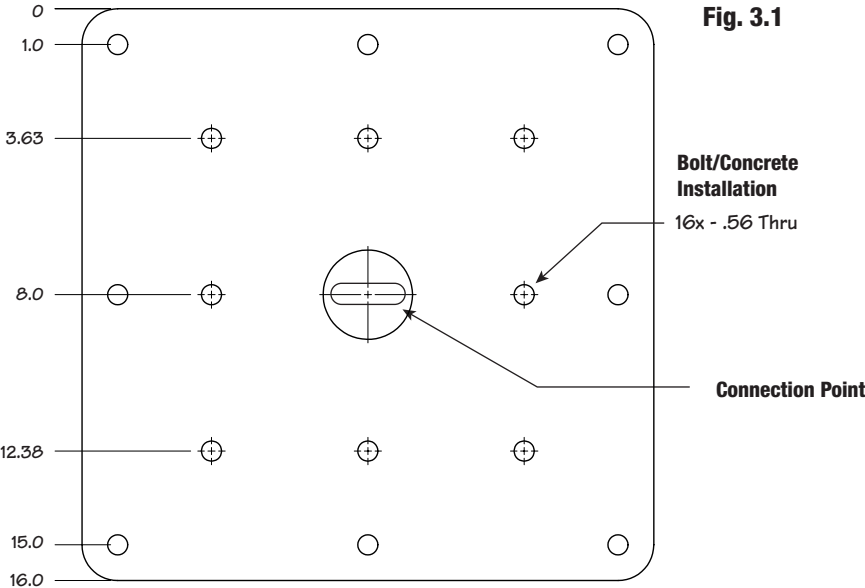

11" - 8 Hole Base Plate

Loop Cross Section: .625"
 Tube: 4" Round
 Base: 11" x 11" Square
 Steel Thickness: .625"
 Strength Rating: 5,000 lbs.

CRA -11" square base plates are fabricated with 8 - 1/2" holes. Any one of 8 - 1/2" holes may be used for bolt or concrete embedment. Bolt holes are purposely oversized.

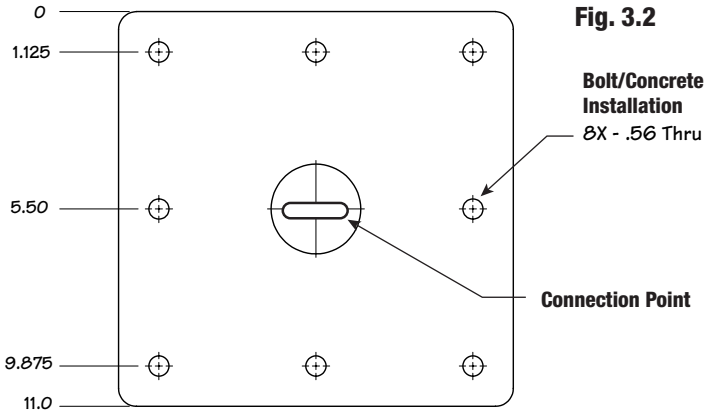

8 Hole Backer Plate

Part Number: 48691
 Base: 11" x 11" Square
 Steel Thickness: 3/16"
 Overall Height: .75"
 Strength Rating: 5,000 lbs.

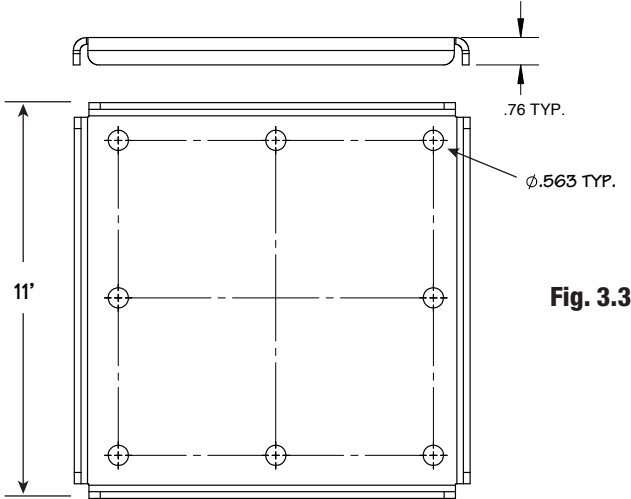

Post-Type Roof Anchor Wood Roof Installation

Fastener Specifications:

Anchors include (40) #14 x 2.5" type A milled point screws for METAL and WOOD applications. Anchors for CONCRETE applications not included. Use only Tie Down supplied or specified fastener types as shown in fig 4.1. Do not substitute with other types unless they have been engineered by a qualified person.

Bolt Attachment:

Risers over 18" are required to be bolt attached with a min. of 4 each 1/2" dia. grade 8 stainless steel or type A307 all thread w/lock nuts Steel backer plates are required unless the CRA is bolted directly to a structural steel member.

WOOD DECKING INSTALLATION:

The anchor must be installed in the center of a plywood sheet that is 48"x 48" and is secured to at least 3 top trusses see fig. 4.2. Minimum thickness of plywood decking is 1/2" with 3/4" backer, see fig. 4.2. The deck sheathing must be secured at all perimeter edges, 8" on center using deck screws. Secure a sheet of 3/4" x 48" plywood reinforcement board as shown in fig. 4.3 & 2, cut to fit between the inside width of the truss spacing. Attach the reinforcement board to the deck sheathing using the same 8" on center and screws. Anchor Fastening Specification: Attach the anchor using at least 40 -2.5"x #14 hex head screws. The fasteners must penetrate through the reinforcement board. A visual inspection should be taken to verify that the fasteners are installed through the board.

For trusses with 24" spacing, center the anchor as shown in fig. 4.3. For trusses less than 24", two reinforcement boards must be used and the anchor centered over the truss as shown in fig. 4.4. Additional screws for reinforcing decking not supplied by Tie Down. All anchorage methods must be inspected and certified by a professional engineer or qualified person.

Structural Support:

The anchor attachment point must be structurally capable of supporting 5,000 lbs. or 2 times the intended fall protection load per OSHA 1910.140(13). 3rd party structural engineering is available from Tie Down upon request.

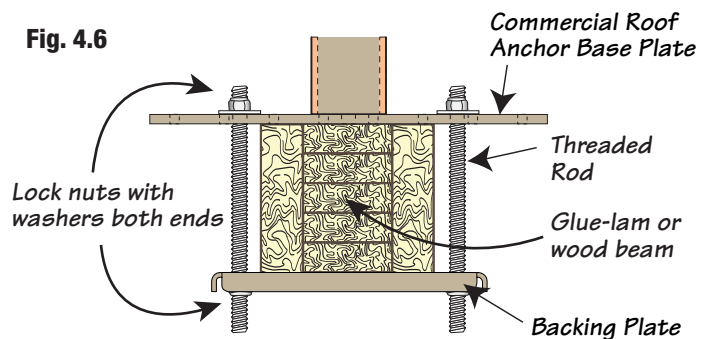
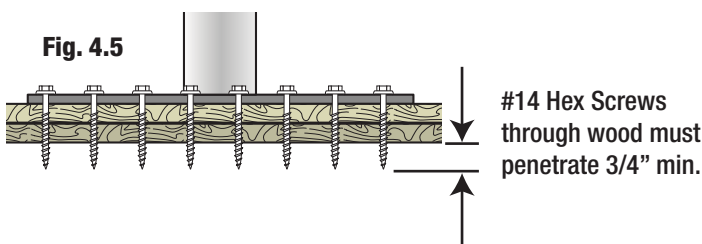
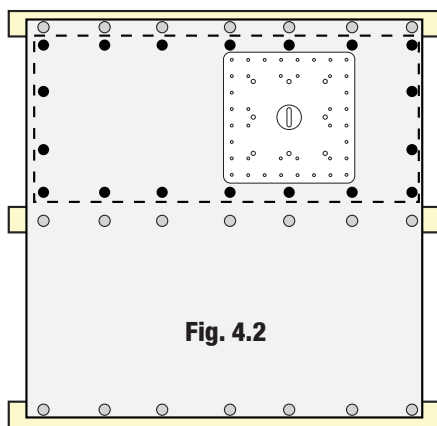
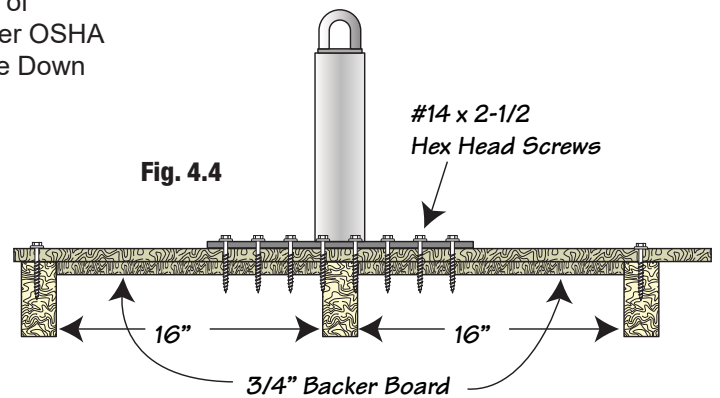
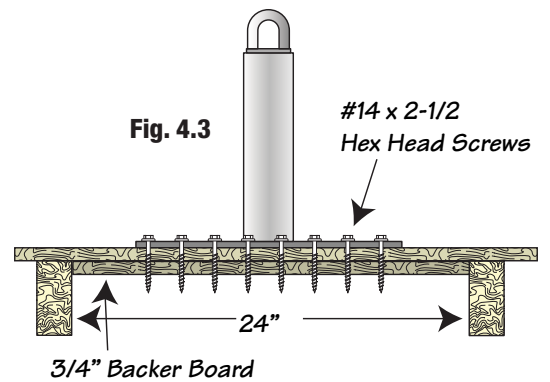
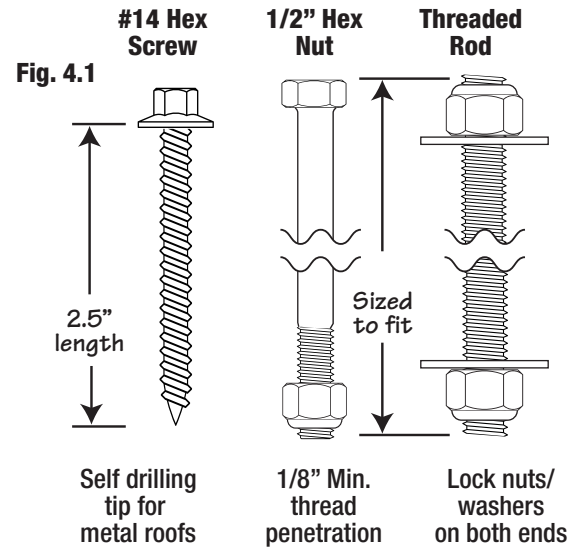

Post-Type Roof Anchor Metal Roof Installation

Fastener Specifications:

Anchors include (40) #14 x 2.5" type A milled point screws for METAL and WOOD applications. Anchors for CONCRETE applications not included. Use only Tie Down supplied or specified fastener types as shown in fig 5.1. Do not substitute with other types unless they have been engineered by a qualified person.

Bolt Attachment:

Risers over 18" are required to be bolt attached with a min. of 4 each 1/2" dia. grade 8 stainless steel or type A307 all thread w/lock nuts Steel backer plates are required unless the CRA is bolted directly to a structural steel member.

CORRUGATED STEEL ROOF DECKING

The roof structure with steel decking that the roof anchor is to be installed onto must meet the minimum strength of 5,000 lbs. A professional engineer or qualified person must certify that the anchorage meets this requirement. The steel decking material must be a minimum of 20 gauge. Additional structural members may be needed to allow the anchor to be securely attached to the primary roof structure. Align the anchor base plate fastener holes over the raised channel of the steel decking as shown in fig. 5.2. Attach the anchor to the metal deck using 40 #14 x 2.5" self tapping hex head screws. Do not over tighten fasteners. Steel Decking less than 20 gauge: Attach a second layer of metal decking 36" x 36" (915 x 915 mm) as shown in fig. 5.3, over the primary metal decking. Attach the second layer to the primary using #14 deck screws, 8" (204 mm) on center through all raised channels of the metal decking.

Fig. 5.1

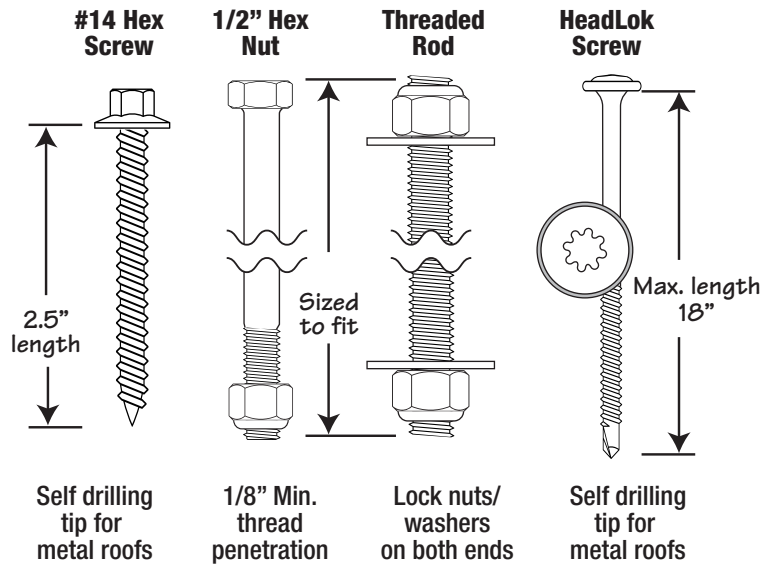

Structural Support:

The anchor attachment point must be structurally capable of supporting 5,000 lbs. or 2 times the intended fall protection load per OSHA 1910.140(13). 3rd party structural engineering is available from Tie Down upon request.

Fig. 5.2

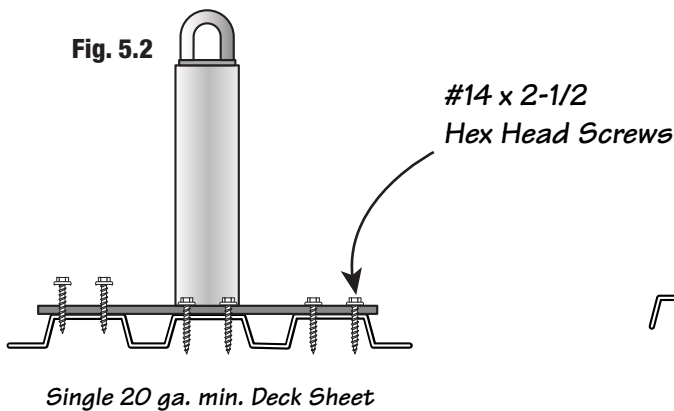

Fig. 5.3

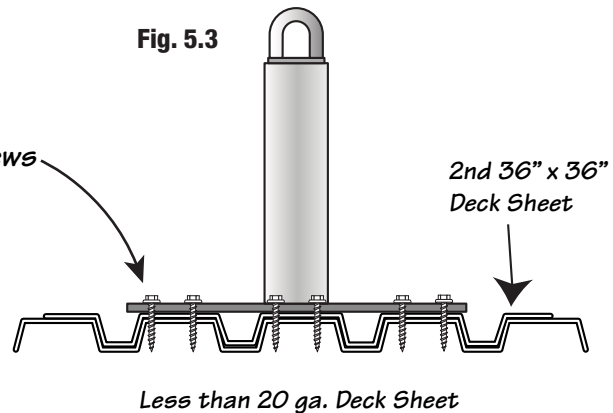

Fig. 5.4

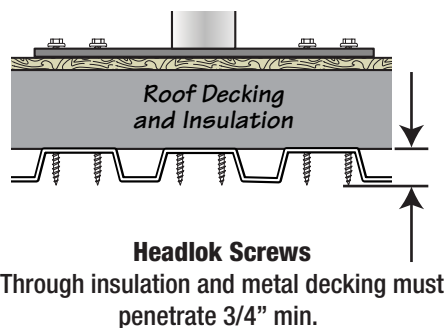
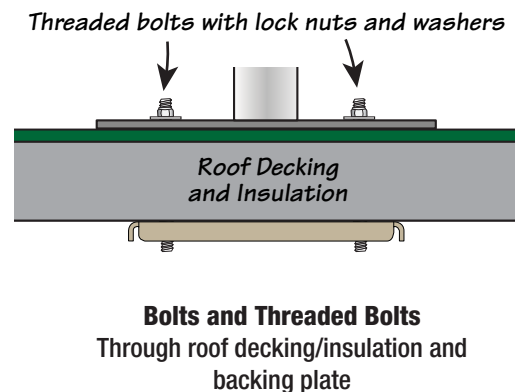

Fig. 5.5



Post-Type Roof Anchor I-Beam Installation

Beam Bolt Attachment:

Risers over 18" are required to be bolt attached with a min. of 4 each 1/2" dia. grade 8 stainless steel or type A307 all thread w/ lock nuts steel backer plates are required unless the CRA is bolted directly to a structural steel member

Structural Support:

The anchor attachment point must be structurally capable of supporting 5,000 lbs. or 2 times the intended fall protection load per OSHA 1910.140(13). 3rd party structural engineering is available from Tie Down upon request.

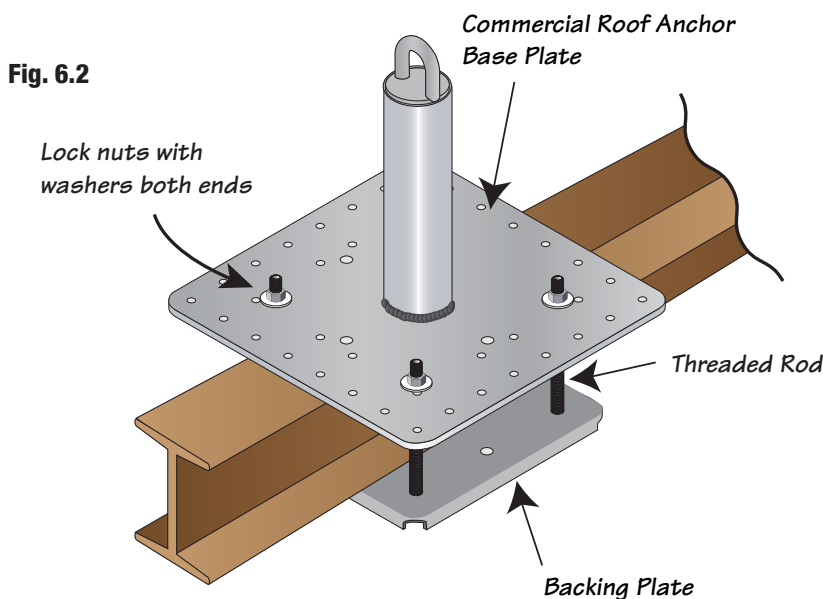

Field Welded:

For the field weld CRA's they will need to be welded to a material that is structurally as strong as the equivalent base plate thickness for the same size CRA. Welding required to be performed by a certified welder. All field welds must be inspected by engineer or structural inspector.

Structural Support:

The anchor attachment point must be structurally capable of supporting 5,000 lbs. or 2 times the intended fall protection load per OSHA 1910.140(13). Third party structural engineering is available from Tie Down upon request.

Fig. 6.1

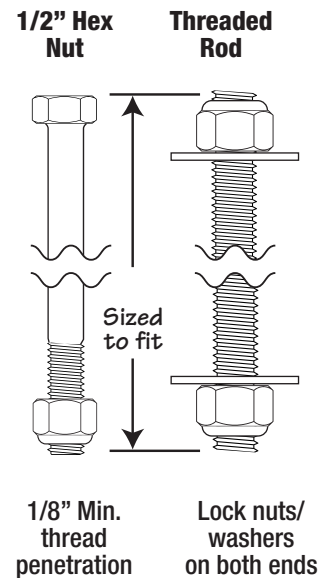
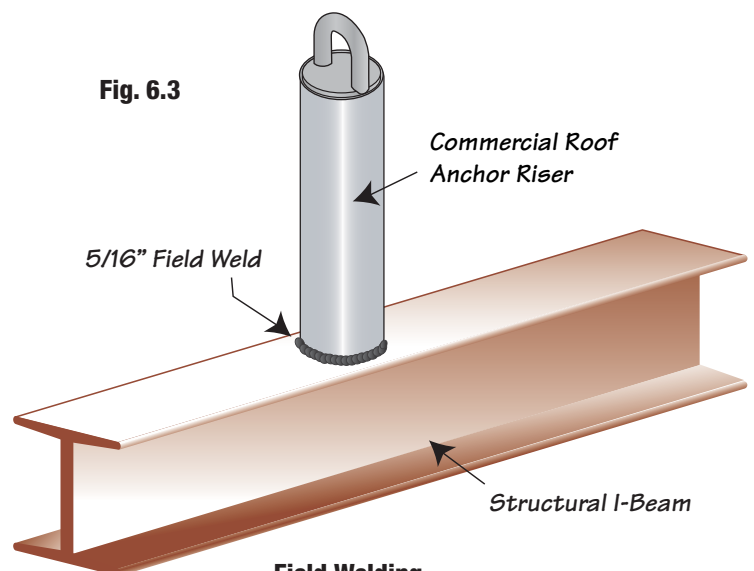

Fig. 6.3



Field Welding

Apply 2 coats or more of a rust preventative coating to all field welds and raw risers

Post-Type Roof Anchor Concrete Installation

Concrete:

The concrete that the roof anchor is to be installed onto must have a minimum thickness of 4" and be rated at 2,000 psi. min. Use 8 - 1/2" wedge anchors (not supplied) rated at 6,000 lbs, to attach and align as shown in fig. 6. The concrete must be fully cured to withstand the required 5,000 lb. load before using.

Concrete Embedment Bolts:

Wedge type 1/2" dia. to be specified by project architect/engineer and installed per bolt mfg. specifications. Flat washers are required.

Poured in Place:

1/2" dia. J bolts or equivalent specified by architect or engineer.

Concrete PSI:

2500 lbs. min. concrete must be sufficiently cured to support the fall protection load.

Anchor/Bolt Attachment:

Risers over 18" are required to be bolt attached with a min. of 4 each 1/2" dia. grade 8 stainless steel or type A307 all thread w/lock nuts steel backer plates are required unless the CRA is bolted directly to a structural steel member.

Structural Support:

The anchor attachment point must be structurally capable of supporting 5,000 lbs. or 2 times the intended fall protection load per OSHA 1910.140(13). 3rd party structural engineering is available from Tie Down upon request.

Fig. 7.1

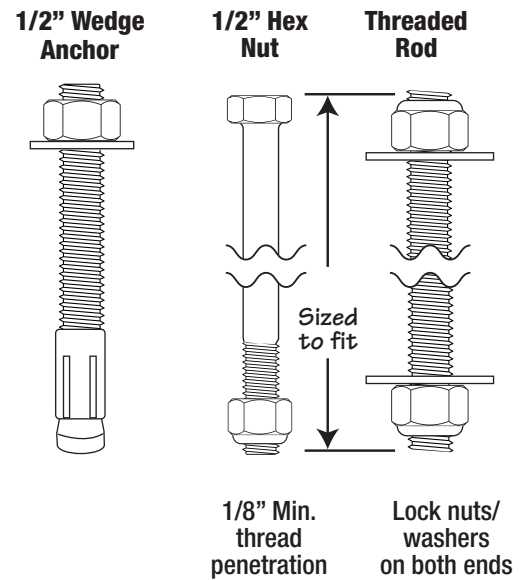

Concrete Embedment (Min.)

CRA Size	Bolt Size	Base
8 inch	3.5"	
12 inch	3.5"	11" x 11"
18 inch	3.5"	&
24 inch	4.5"	16" x 16"
36 inch	5.5"	

Fig. 7.3

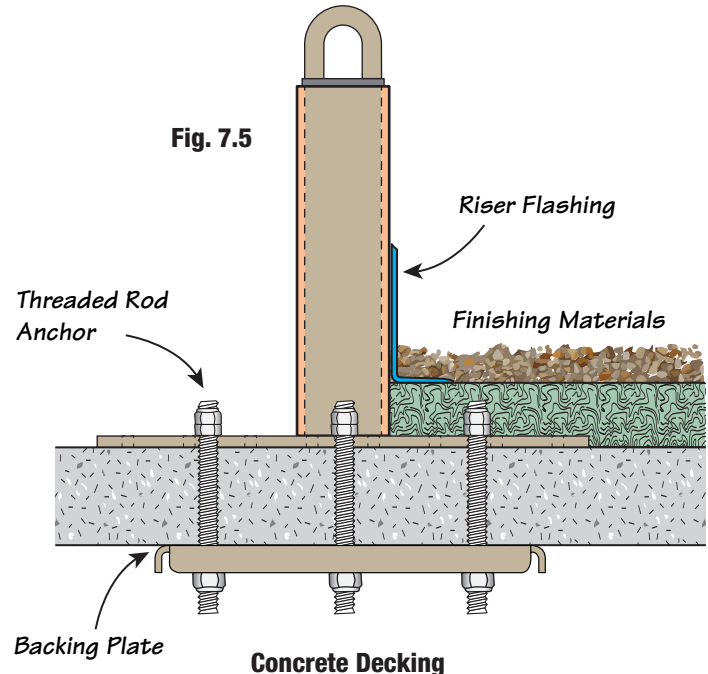
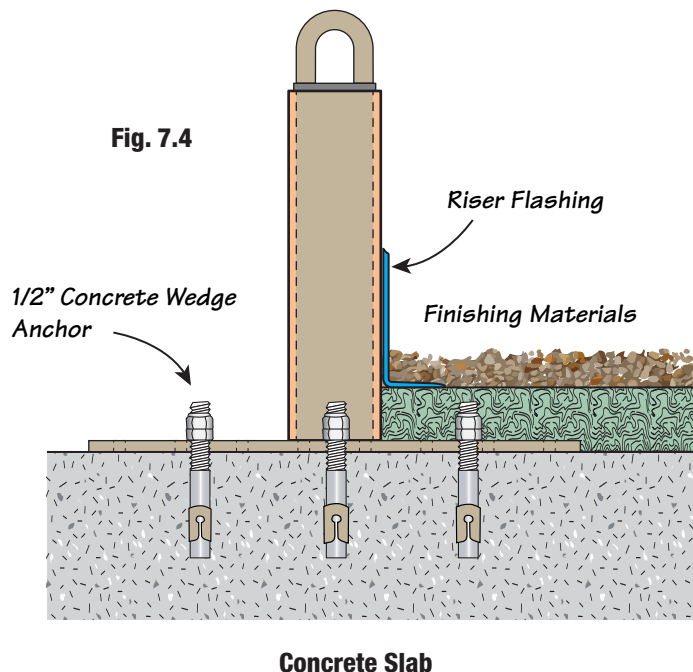

Window Washing Anchors

Bolt attached, reference fig (4.6, 5.5, 6.2), field welded, reference fig (6.3) or concrete embedded, reference fig (7.3, 7.4) . Two anchors are required for each drop point designation: 1 suspension rope anchor use for the workers boatswain chair and one fall arrest anchor.

Users/Installers must adhere to spacing requirements noted below.

Max. Spacing of 12' between Fall Arrest Anchor and Suspension Anchor @ Max. 15° Angle from Perpendicular

Min. Spacing of 2' between Fall Arrest Anchor and Suspension Anchor @ Max. 15° Angle from Perpendicular

Do not locate anchors closer than 6 ft. to the edge.
Always protect rope exposure to edge surface and abrasion.

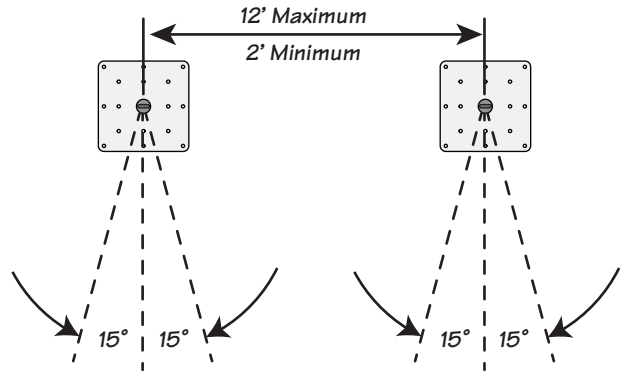

ANSI/IWCA.1-14.1 Applicable Standards:

- 1) Analysis of the anchors structural supporting member shall be performed by a registered professional engineer*. 9.1.7
- 2) Anchors used for fall arrest shall be independent from the anchorage used for the suspension system. 13.3.3
- 3) Fall arrest lifeline max. angle 15° from perpendicular. 5.7.17(d)
- 4) Workers may not reach more than 6 ft left or right from the drop point. 5.7.10
- 5) Anchors closer than 6 ft from the roof edge, parapet wall or drop point. Max spacing between anchors is 12 ft. Appendix C
- 6) Anchors inspected annually by a “qualified” person. 9.1.9
- 7) Anchors re-certified at least every 10 yrs. 9.1.9 by a registered professional engineer. 9.1.10 *Project architect/ engineer.

CRA ID and Inspection Tag

The Competent Person must sign their initials in the box corresponding to the month and year the inspection took place. If either tag or labels are damaged or unreadable please contact Tie Down for replacements.

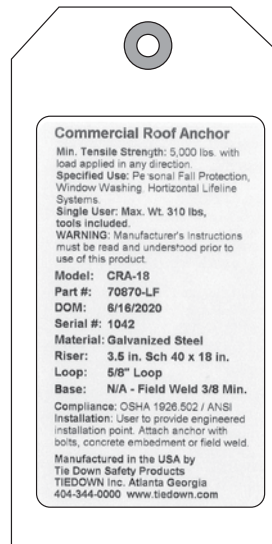
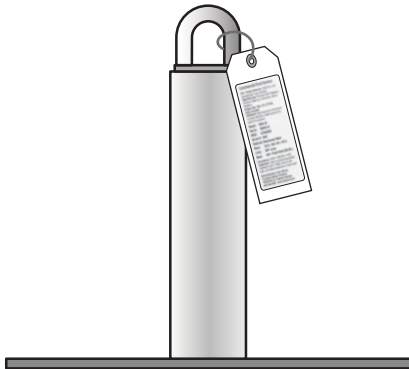

CRA ID Tag

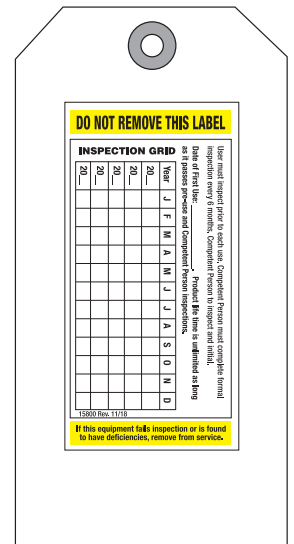

Inspection Tag on Reversed Side



Made in USA