



Safety Rail Source®

LADDER SAFETY-LEGS

INSTALLATION INSTRUCTIONS

- Point Safety-Leg toward the wall
- Set mounting plate against ladder rail
- Wrap strap around ladder rail and thru ratchet axle slot
- Pull strap tight
- Operate ratchet to tighten strap
(Note: make sure leg is touching the ground)

**Remember to
always erect
your ladder
using the 4:1
rule**

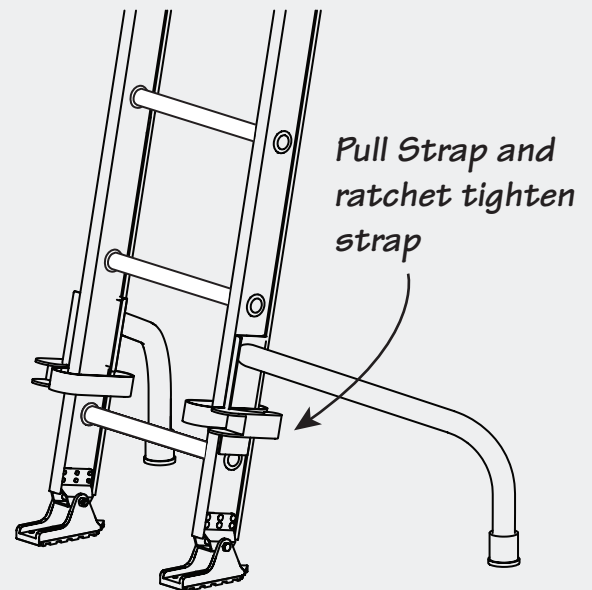
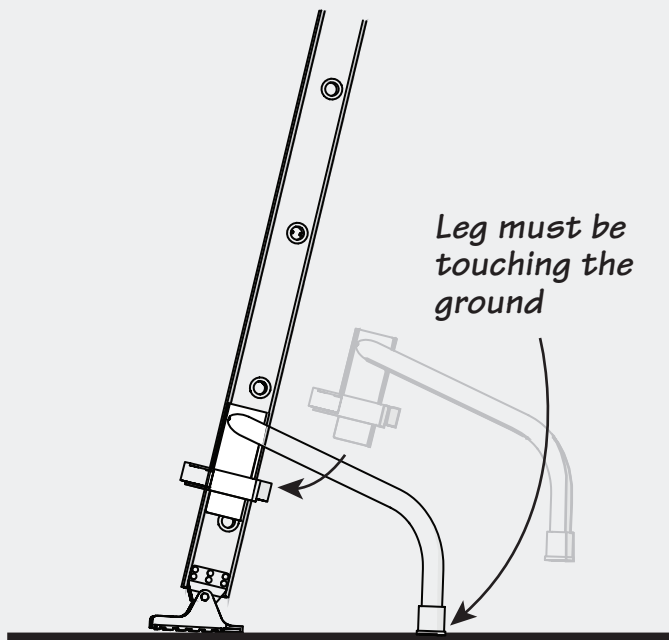

Warning: Do not attempt to climb the ladder unless the ladder is installed per manufacturer's requirements. Do not alter or use the Ladder Safety-Legs for any reason other than what is depicted in the instructions and shown in the images. If you have any questions, please contact Safety Rail Source at (877) 723-3766.



Made in USA

Safety Rail Source®
2570 Blvd of the Generals, Ste.200
Norristown, PA 19403
(877) 723-3766
www.SafetyRailSource.com