

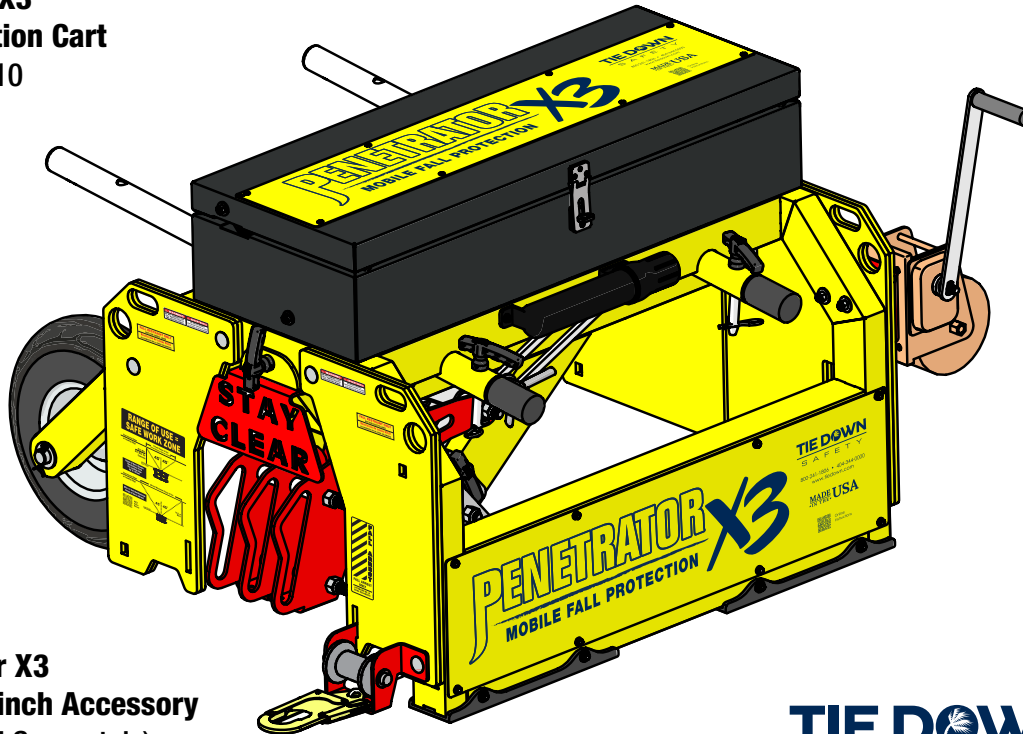

PENETRATOR X3 MOBILE FALL PROTECTION

**Penetrator X3
Fall Protection Cart**
Part ID: 72810



**Penetrator X3
Rescue Winch Accessory**
(Purchased Separately)
Part ID: 72819

TIE DOWN
MANUFACTURING INGENUITY

⚠️ **WARNING** ⚠️

Serious injury or death may occur if this equipment is used for purposes other than intended. Tie Down Engineering provides the following instructions for the use and care of this equipment. It is the responsibility of the user to understand and convey proper instruction to any and all individuals who use this product for Fall Arrest and or Fall Restraint. The Penetrator X3 complies with the requirements set forth by the Federal Occupational Safety and Health Administration (OSHA) when used according to the manufacturers' instructions.

WARNING: This product can expose you to chemicals including Nickel, which is known to the State of California to cause cancer. For more information go to: www.P65Warnings.ca.gov

Instruction #08383 (E1847 - Rev. 9/24/21)

PENETRATOR

X3 MOBILE FALL PROTECTION

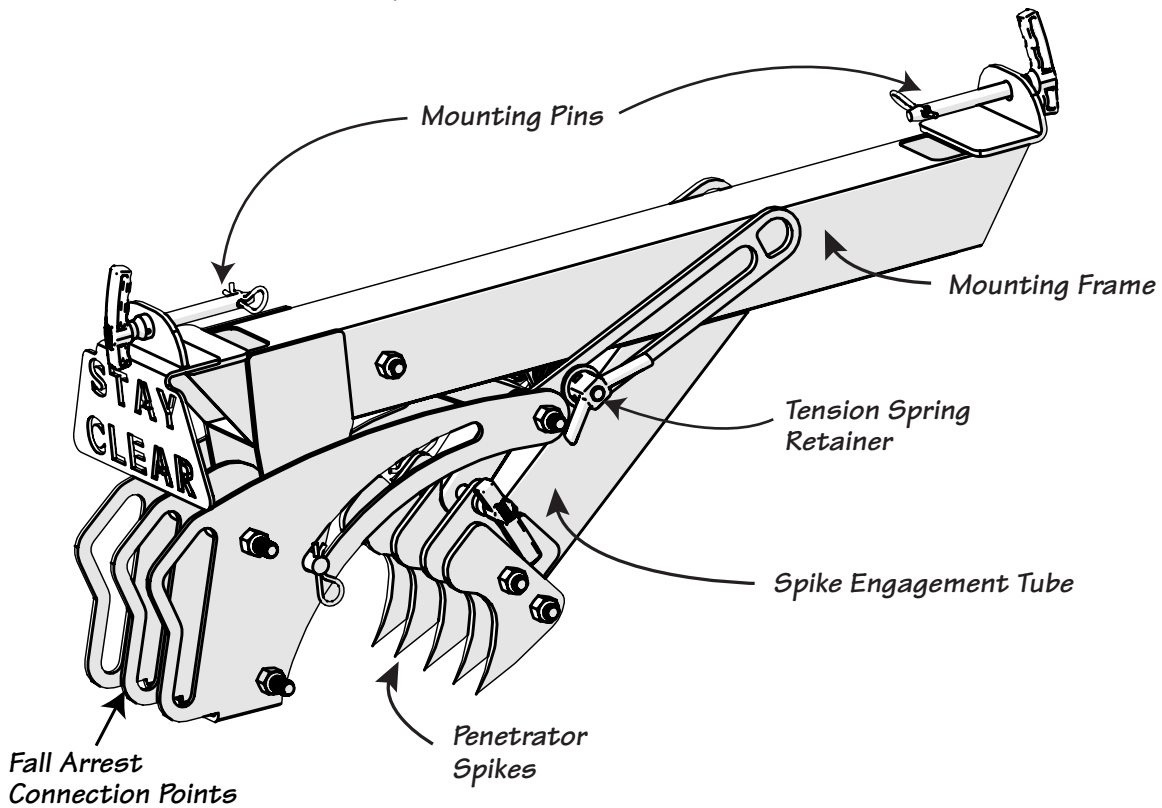
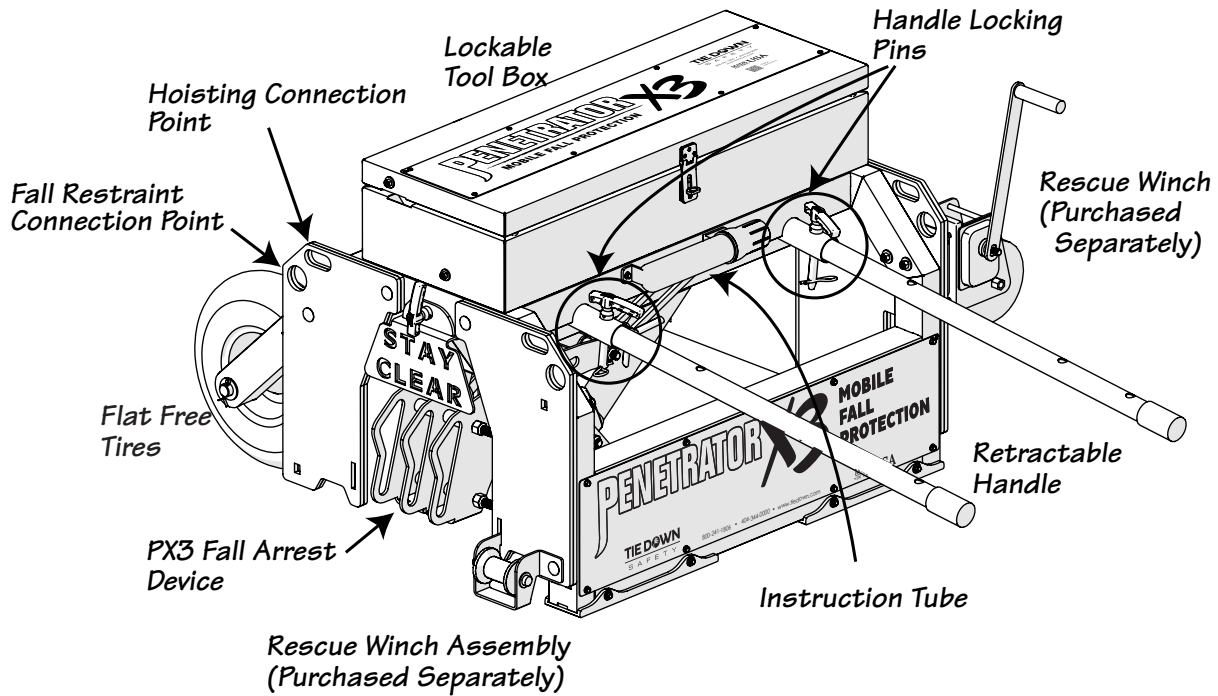

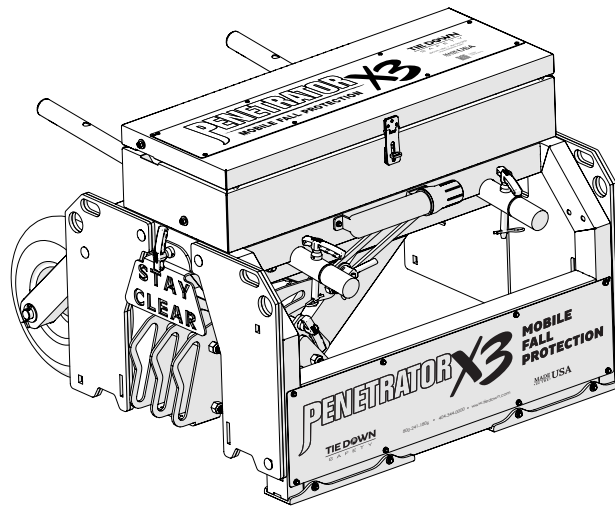

PENETRATOR X3 MOBILE FALL PROTECTION

Applications

When set up properly the Penetrator X3 allows for two workers to be tied off for fall arrest using the specially designed fall arrest connection mechanism with two individual attachment points. An additional two workers can be tied-off for fall restraint at the specified attachment points.

Fall Restraint System – A fall restraint system (FRS) prevents the user from falling. The system is comprised of a body harness along with an anchorage, connectors and other equipment. The components typically include a lanyard and also may include a lifeline and other devices. The Penetrator X3 can be used as an anchorage in a fall restraint system for up to two workers.

Personal Fall Arrest System – A personal fall arrest system (PFAS) arrests a fall after a fall incident has occurred. The system is comprised of an anchor point, connecting device, body harness, connectors, and a body harness and must include a deceleration system, or suitable combinations. Note that a PFAS does NOT prevent a fall from occurring. The Penetrator X3 can be used as an anchorage in a PFAS for up to two workers. A Personal Fall Arrest System must meet the following OSHA requirements:

- Limit maximum arresting force on an employee to 1,800 pounds when used with a body harness;
- Be rigged (lifeline plus deceleration device) so that an employee can neither free-fall more than 6 feet (1.8 meters) nor contact any lower level;
- Bring an employee to a complete stop and limit maximum deceleration distance an employee travels to OSHA 3.5 feet (1.07 meters); and 4 ft. per ANSI 359.
- Have sufficient strength to withstand twice the potential impact energy of an employee free-falling a distance of 6 feet (1.8 meters) or the free-fall distance permitted by the system, whichever is less.

Anchorage — An anchorage is a secure point of attachment for lifelines, lanyards, or deceleration devices. The Penetrator X3 is a mobile anchorage.

Penetrator X3 Use - Flat surfaces to slopes up to 1:12.

Applications: Surfaces

Recommended Surfaces:

- ✓ Thermoplastic Polyolefin (TPO) Membranes
- ✓ Polyisocyanurate (ISO)
- ✓ Expanded Polystyrene (EPS)
- ✓ EPDM Roofing Membranes
- ✓ Ballasted EPDM Membrane
- ✓ Metal Deck (20 ga. and 22 ga. ONLY)
- ✓ Plywood

Do Not Use on the Following Surfaces:

- ✗ Metal Deck less than 22 ga.
Or over 20 ga. (Structural Deck)
- ✗ Loose laid material not part of a complete finished system.
- ✗ Ice
- ✗ Snow
- ✗ Tectum Deck
- ✗ Concrete

Roofing Load Requirements

Before the Penetrator X3 and cart are hoisted to any roofing deck the user MUST VERIFY THAT THE DECK CAN ACCOMMODATE THE LOAD REQUIREMENTS.

Verify that the surface that the Penetrator X3 will be used on is capable of supporting both the unit and personnel using it. Inspect that the entire area to determine if the working surfaces have the strength and to support users safely.

CAPACITY: The Penetrator X3 Mobile Fall Protection System is designed for a maximum of three persons for fall arrest and two for fall restraint with a combined weight (clothing, tools) of no more than 310 lbs. per person. No more than four persons may be connected to the Penetrator X3 at any time.

IMPORTANT: DO NOT start work for which fall protection is required until the Penetrator X3 and corresponding FRS or PFAS have been completely installed. Do NOT disable any part of the FRS or PFAS, including the Penetrator X3 unit, or reposition the unit, until work for which fall protection is required has ceased.

Range of Use

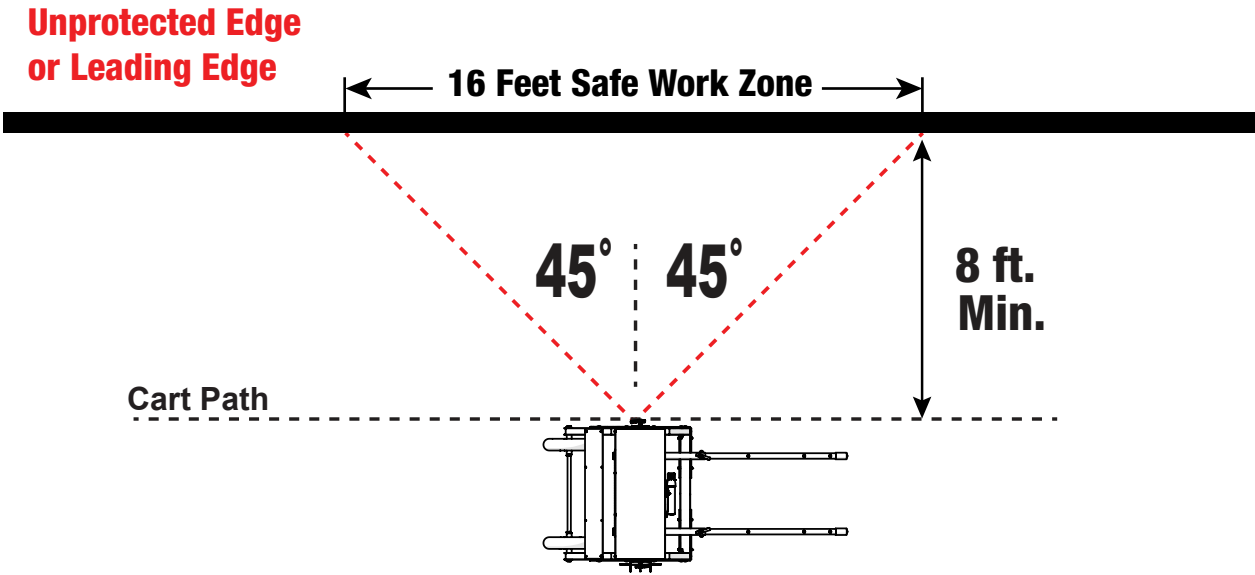

Range of Use is double the distance from the leading edge up to 15 feet.

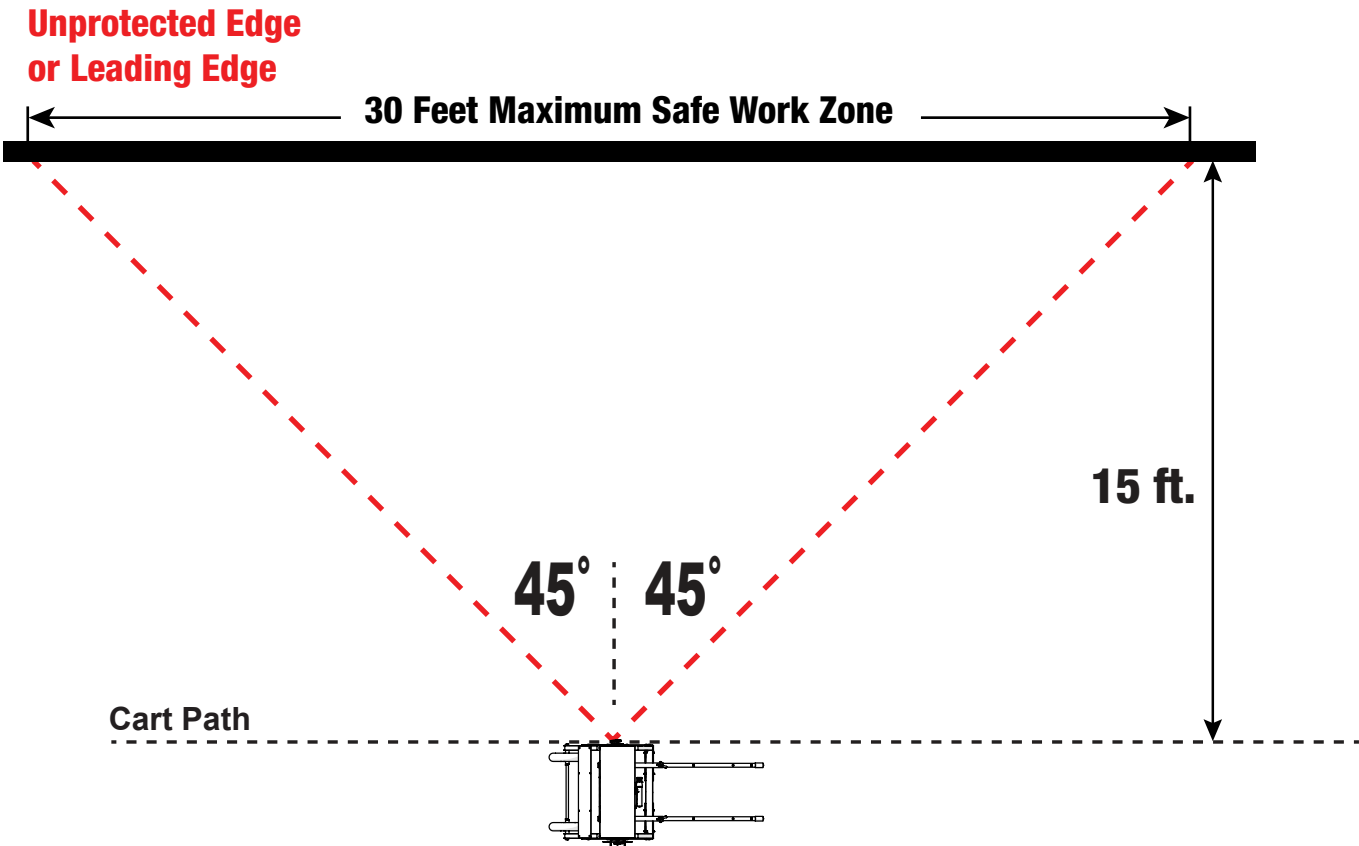

After 15 feet the maximum Range of Use is 30 feet.

Connecting to the Penetrator X3

DO NOT hook Personal Fall Arrest System (PFAS) to any point except a Fall Arrest or Fall Restraint Tie-off Anchor Point.

When making connections, only use double-locking snap hooks and double-locking carabiners with this equipment. Only use connectors that are suitable to each application. Ensure all connections are compatible in size, shape and strength. Do not use equipment that is not compatible. Ensure that all connectors are fully closed and locked.

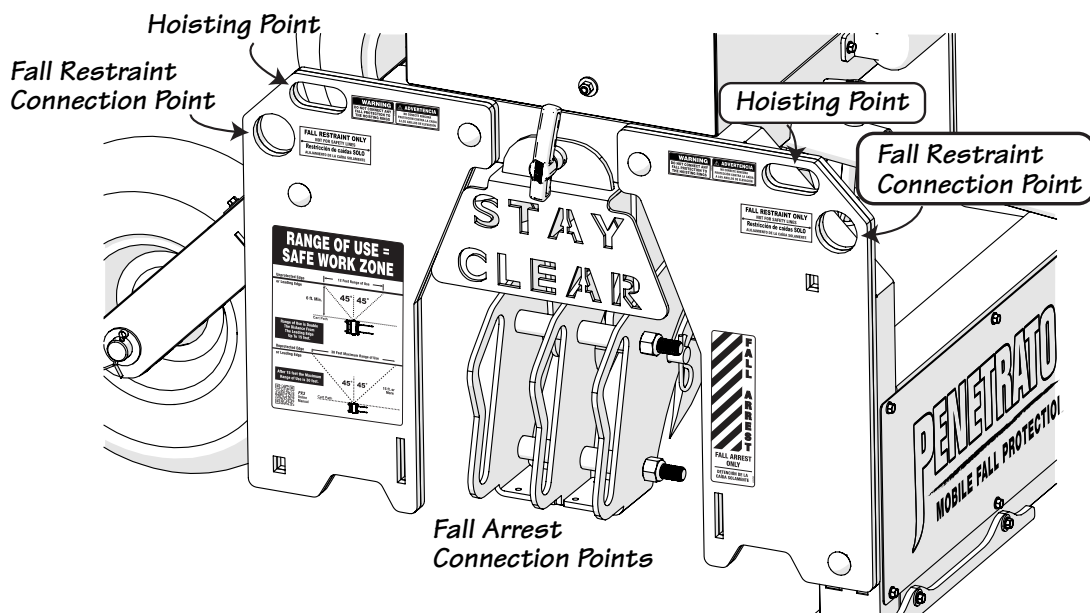

The Fall Restraint Tie-Off

Two Fall Restraint Anchor tie off's are located on the top corners of the Penetrator X3 where labeled. The Fall Restraint tie off's DO NOT arrest falls. The user must insure that the Fall Restraint worker is personally equipped with lanyards, harnesses, safety lines, etc., when working in conjunction with potential fall arrest workers.

Do not attached fall restraints to the hoisting ring locations.

Do Not allow the fall restraint users to work close to any roof edge.

FALL ARREST TIE-OFF

The three Fall Arrest Tie Off points are located on the lower side of the Penetrator X3 in bright red, under of the stay clear guard. The user must insure that the lanyards and harness are properly attached.

IMPORTANT: DO NOT allow workers to cross paths (cross lines) at anytime! Fall Restraint/Fall Arrest lines must never cross over each other. Crossed lines will cause the unit to not function as intended. Failure to maintain clear lines may cause a accident or death.

DO NOT OPERATE DAMAGED EQUIPMENT. DO NOT OPERATE EQUIPMENT THAT HAS BEEN MODIFIED.
(Please use the Inspection and Maintenance Log contained within the instructions manual)

Before Using the Penetrator X3

OSHA requires that before operating the system there must be an inspection for damaged equipment.

- 1 Check for loose, bent or damaged parts, including the three penetrating spikes.
- 2 Check welded components for distortion, cracks, or other damage.
- 3 Check Tie-off shackles for distortion or damage and confirm that they are properly tightened.
- 4 Check retaining slide bars for rusting and/or wear before each use.
- 5 All labels must be present and fully legible. (Copies of all labels are attached at the back of this section for accurate inspection.)
- 6 Check for all pull pins that they are fully inserted and the safety cotter pin clips are attached to each pull pin.

Maintenance and Care

- ✓ Inspect Penetrator X3 before and after each use.
- ✓ Keep wheels free from roofing debris.
- ✓ Regularly inspect for damaged or missing parts and do not place the Penetrator X3 into service until all missing and or damaged parts have been replaced.
- ✓ Store the Penetrator X3 in a place protected from weather and where only authorized employees have access. Optional Penetrator X3 all weather protective cover may be purchased separately.
- ✓ Maintain finish to prevent corrosion.

General Safety Precautions

- **USE COMMON SENSE!** Most accidents can be avoided by using common sense and concentrating on the job at hand. Look around and confirm a safe distance from the roof edge is being maintained.
- The Penetrator X3 should not be used by persons whose ability or alertness is impaired by fatigue, intoxicating beverages, illegal or prescription drugs, or any other physical cause that exposes the user or others to injury.
- Always wear proper safety attire.
- Keep hands and feet clear of moving parts. **DO NOT** stick hands or fingers in the equipment when workers are attached to the Penetrator X3.
- Do not operate the equipment near electrical power lines. **ELECTRICITY KILLS!**
- Ensure that all areas directly underneath, and in front of the cart, are clear and free of debris.
- Do not use on roofs with ice or snow.
- Only use the unit on a surface or roof composition for which it has been tested.
- Do not set unit atop unfastened materials. Materials may slide if not mechanically attached to the roof.

Hoisting Safety Precautions

Loads may slip, if the Penetrator X3 is not hoisted properly, this could result in injury or death.

Do not use with damaged slings or chains.

Utilize appropriate rigging gear for overhead lifting.

Utilize rigging gear within the industry standards and the manufacturer's recommendations.

Conduct regular inspection and maintenance of the rigging gear.

DO NOT hook to the fall arrest or fall restrain shackle safety line connectors when lifting the cart.

Rescue Winch (Purchased Separately)

Rescue Winch Accessory

The Rescue Winch is designed to be used only in case of emergency. The winch is stored safely in the storage tool box and can be quickly installed in case of rescue.

Rescue Winch Kit

Winch, brackets, roller and all hardware.

Part ID: 72819

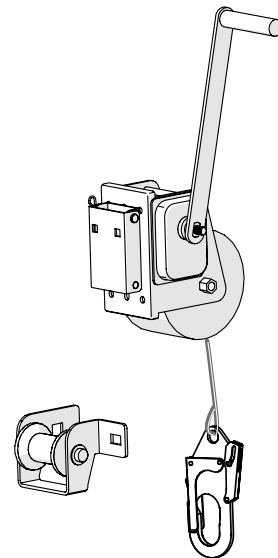

Install the Permanent Winch Mount

From the back side of the PX3 mount the permanent winch mount. Mount the bracket using the mounting holes closest to the handles. Pass 2 - 3-1/2" carriage bolts through the winch mount and PX3 frame. Attach nuts/washers and then tighten nylock nuts. As shown right.

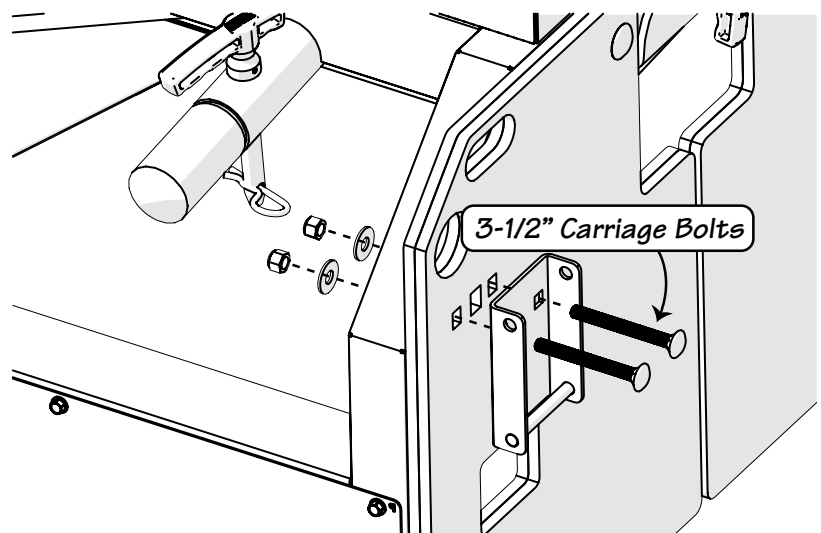

Rescue Winch Installation

Install the Permanent Roller Guide Bracket

It is recommended to use a 1/2" impact wrench for this part of the installation.

There are two options for installing the permanent roller guide bracket assembly:

1. Access the nylock nut by working from the top inside and reaching down.
2. Remove the 8 self tapping screws and the PX3 metal plate.

Use a 1/2" impact wrench to remove the 3.5" carriage bolt, washer and nylock nut.

WARNING - Be careful not to come in contact with the five penetrating spikes.

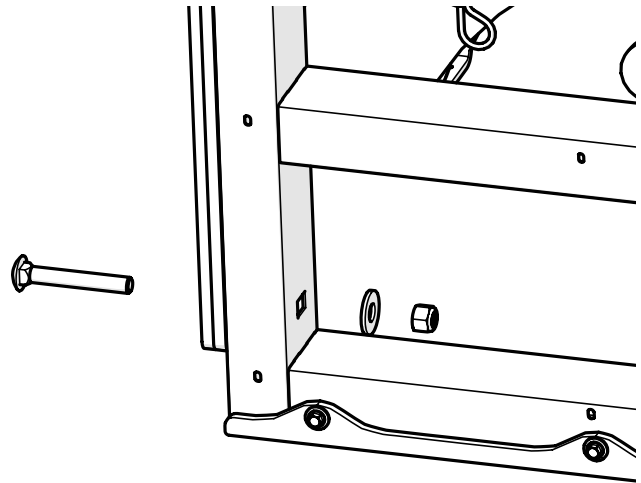

The roller cable guide bracket is assembled and it slides in through the mounting slot and drops down once in position. Make sure the square mounting hole on the right side is aligned with the bracket and PX3 frame.

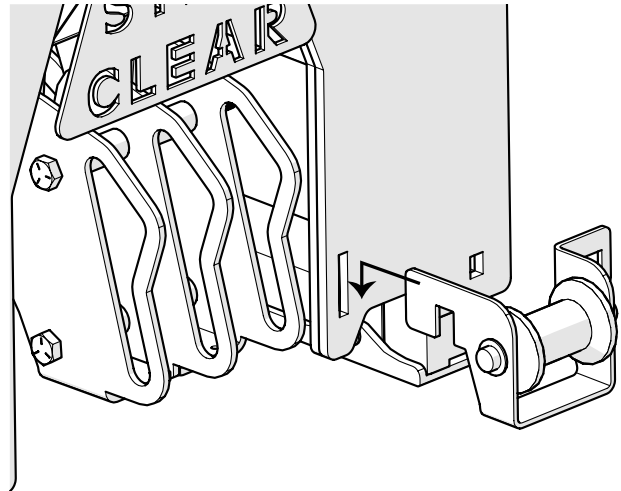

From the front of the PX3 insert the 3.5" carriage bolt through the roller bracket and PX3 frame. Attach 1/2" washer and nut. Use the impact wrench and tighten the nylock nut.

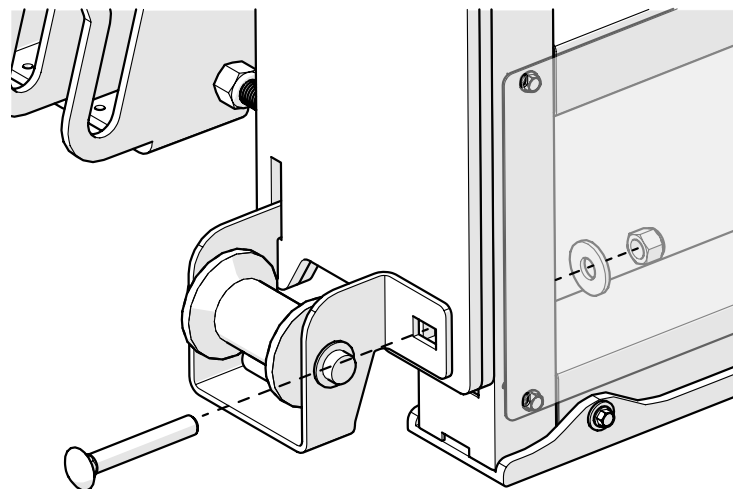

Rescue Event

Rescue Event

In the event of a rescue, remove the rescue winch from the tool storage box. Slide the winch base over and down on the permanent mounted bracket. Make sure the lower slots fit over the mounting pin on the lower portion of the permanent bracket.

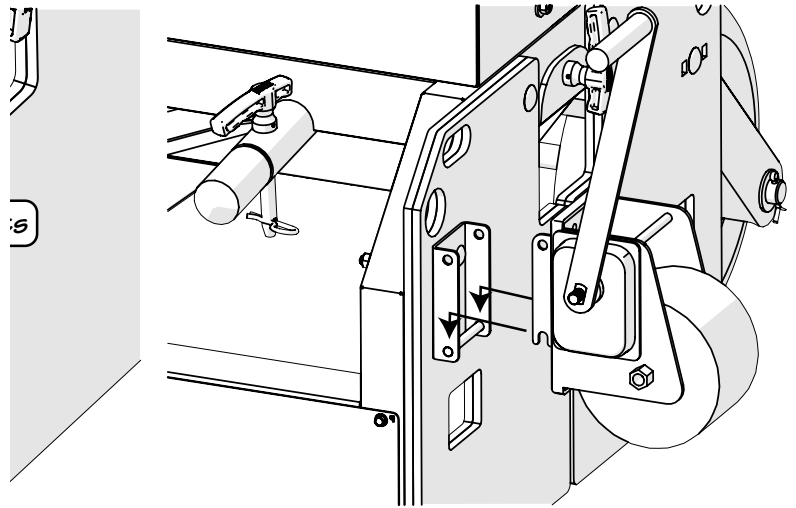

With one hand holding the winch in place, slide the mounting pin in through both winch bracket and the permanent bracket. Slide the pin completely through the other side and secure with a safety pin as shown.

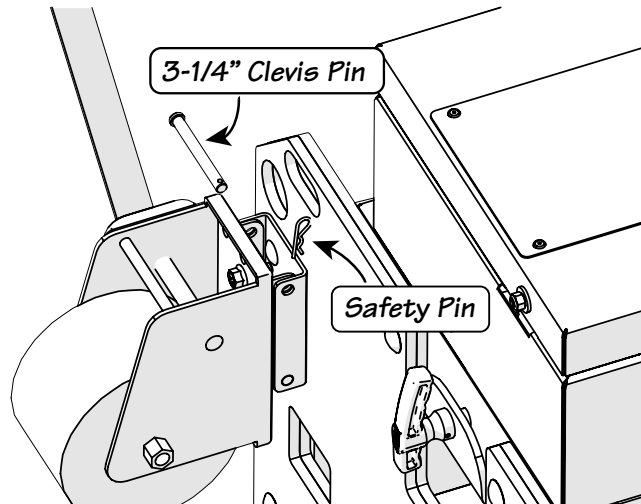

Rescue Event

In the event of a rescue, remove the rescue winch from the tool storage box. Slide the winch base over and down on the permanent mounted bracket. Secure the winch with the 3/8" clevis pin. Release about 4 ft. of cable from the winch. Slide the rescue hook through the hole below the winch. Standing above the PX3, bend over and pass the rescue hook/cable through the roller cable guide bracket. The rescue hook should pass under the roller and about the bottom of the roller bracket.

WARNING - Be careful not to come in contact with the five penetrating spikes.

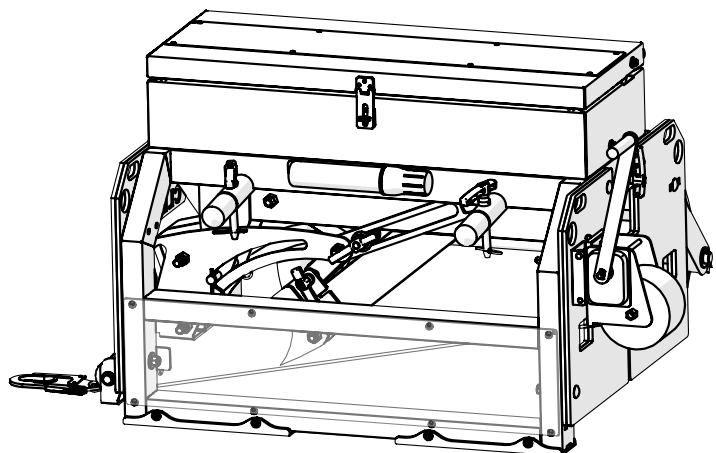

Procedure for Handling the Penetrator X3 After a Fall

Before rescuing a fallen employee....

It is recommended to call 911 before making rescue attempt

Any rescuer must be tied off in a FRS before attempting to aid in a rescue. The number of rescuers allowed to tie off to the Penetrator X3 is 3 minus the number of fallen workers. Up to 2 (two) additional rescuers may tie off to the Penetrator X3 utilizing the two fall restraint tie-off shackles marked for FRS.

To use the Tie Down Rescue System for the Penetrator X3, you will need to also have a rescue pole accessible to properly reach the back dorsal D-ring of the worker who is being rescued. **DO NOT ATTEMPT TO RESCUE THE WORKER UNLESS YOU ARE PROPERLY TIED OFF TO AN APPROPRIATE ANCHORAGE CONNECTION. ATTEMPTING TO RESCUE A WORKER WHEN NOT BEING PROPERLY CONNECTED TO AN APPROVE ANCHORAGE CONNECTION CAN RESULT IN SERIOUS INJURY INCLUDING DEATH.**

Workers must be properly trained in the use of the Tie Down Rescue System PRIOR to use. Do not use the Tie Down Rescue System unless you are trained by a competent person and that training must be documented to have been conducted prior to use. Failure to properly train on the safe use of the Tie Down Rescue System could result in serious injury including death.

Evaluate the situation

The event that led to the fall may create additional risk that need to be addressed. Determine weather the fallen worker is to lifted back to the roof top or lowered to the ground.

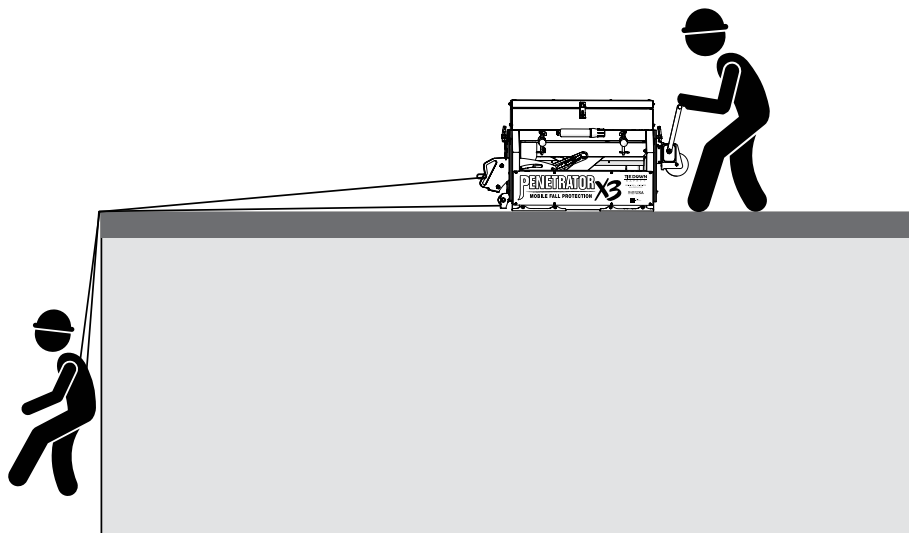

If the Worker is Conscious

Release the cable from the winch and lower it to the fallen worker. Have the fallen worker hook the cable to his harness.

If the cable length and ground conditions allow, it is recommended to lower the worker safely to the ground. If the ground environment is not safe or the cable length is not long enough, then raise the fallen worker to the roof top.

Procedure for Handling the Penetrator X3 After a Fall

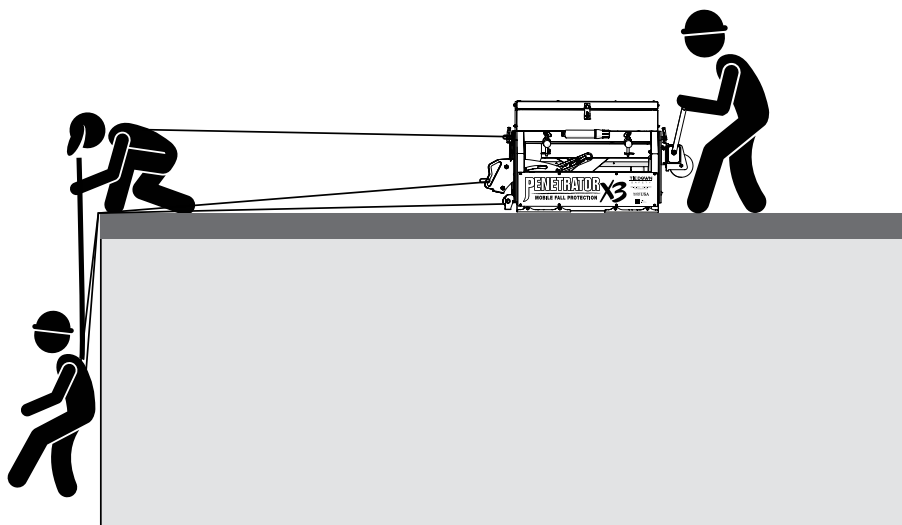

If the Worker is Unconscious

If the fallen worker is unconscious or unable to hook themselves up to the rescue cable additional rescue help will be needed. The additional worker must be tied off to the Penetrator X3. Using a rescue pole attach the hook/cable to the fallen worker.

If the cable length and ground conditions allow, it is recommended to lower the worker safely to the ground. If the ground environment is not safe or the cable length is not long enough, then raise the fallen worker to the roof top.

Treat the worker for suspension trauma and any other injuries.

Arrange for transportation to the nearest hospital.

Procedure for Resetting the Penetrator X3 After a Fall

Prior to disengaging the Penetrator X3 after deployment as the result of an fall incident, make certain that the rescue procedure has been successfully completed.

The five penetrating spikes will be somewhat buried into the roof after activation.

Follow these steps to reset the Penetrator X3 Device:

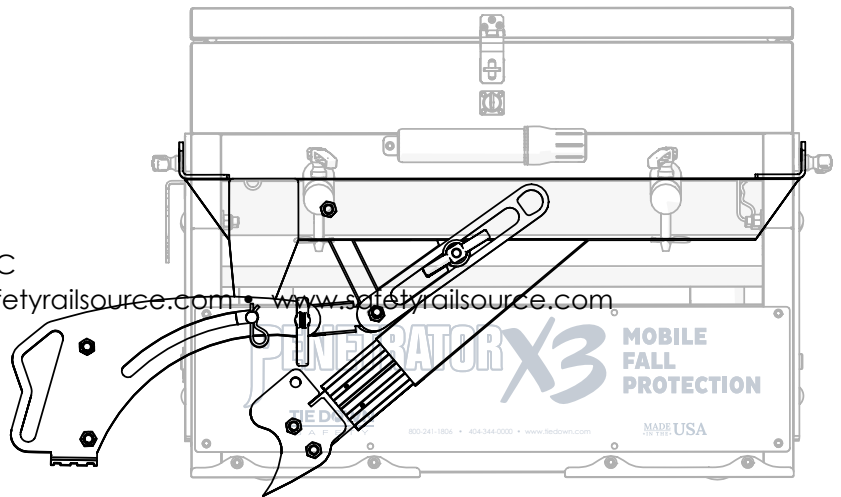

PX3 Device shown in the engaged position

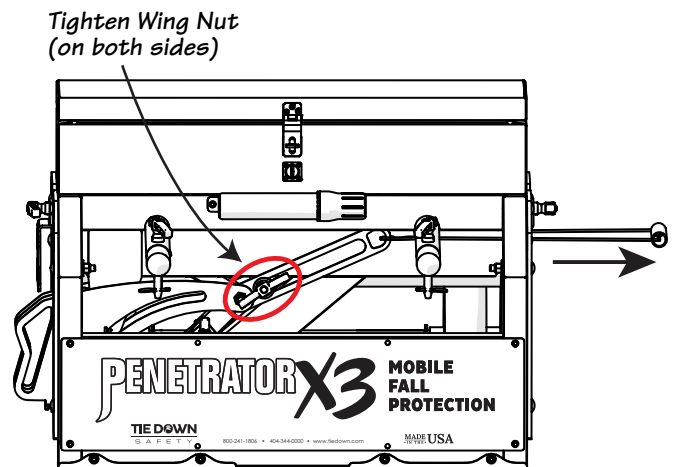
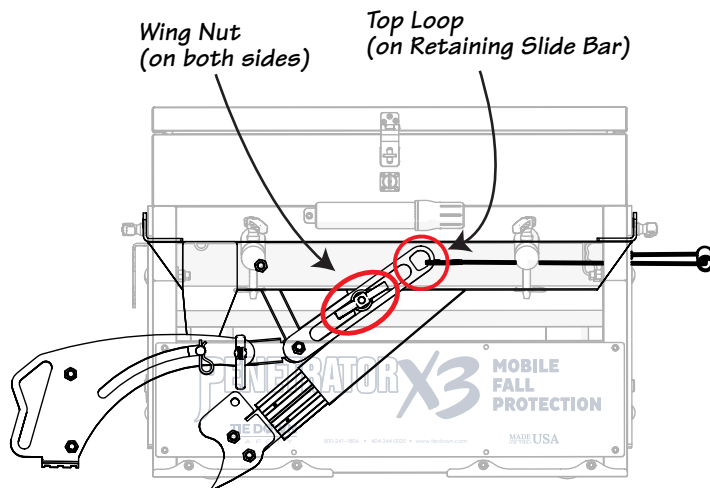

1. Loosen the large wing nuts on both sides of the PX3 device.
2. Attach the pull hooks to the top loop of the retaining slide bar. Repeat for opposite side.

3. With a firm pull, pull the handle outward away from the PX3 cart. The Spike assembly will slide back to it's original position.
4. Re-tighten the large wing nuts on both sides.

Do not reuse the Penetrator after incident until fully inspected and any damaged parts have been replaced and recertification and inspection has been performed. See inspection check list on back cover.

DECLARATION OF CONFORMITY

Declaration Date: 08.11.2021
Rev. 0

DECLARATION NO.	ETR-72810, 72841_R0
PART NUMBER(S):	72810, 72841
PART DESCRIPTION:	Penetrator X3 Cart (PX3)
ADDITIONAL INFORMATION REGARDING THIS DOCUMENT OR STANDARD(S) EVALUATED:	
•	

TIE DOWN ENGINEERING DECLARES THAT THE PRODUCT(S) LISTED ABOVE IS IN CONFORMITY WITH THE REQUIREMENTS OF THE FOLLOWING PERFORMANCE STANDARDS.

STANDARD(S):
<ul style="list-style-type: none">• OSHA 1926 Fall Protection Criteria• OSHA 1910 Personal Fall Protection Systems

*** This certificate declares that the above standard(s) was met by the requirements of such standard(s). Testing was performed under normal operating measures. The results of testing apply only to the sample(s) tested and to the specific test(s) performed. This certificate is only issued for products which have passed the testing requirements of the standard(s) listed. The end-user is responsible for using the product(s) for its intended purpose(s) only and must review all manuals and instructional documentation prior to use. ***

Tie Down Engineering, Inc.
605 Stonehill Drive, SW
Atlanta, GA 30336

404-344-0000
sales@tiedown.com
www.tiedown.com

Safety Rail Source, LLC
2570 Blvd of the Generals, Suite 200
Norristown, PA 19403



Test Report		
Test Operator(s):	Wilson Ha, Lynea Rivera, Daniel Mathis	
Test Date:	8/9/2021	
Part Number(s):	72810, 72841	
Part Revision:	0	
Internal Test Report:	ITR-72810, 72841_R0	
Third Party (if applicable):		
Test Specification	Test Summary	
OSHA 1910 Subpart I App D	Test Criteria	
OSHA 1926 Subpart M App C	Test Result	
	<ul style="list-style-type: none"> 6 ft. freefall drop test using a 310 lb. test mass Test performed with 6 ft. PEA's. Test mass must not hit the ground or floor. 	PASS
	<p>1910.140(d)</p> <ul style="list-style-type: none"> Personal fall arrest systems— 1910.140(d)(1) System performance criteria. In addition to the general requirements in paragraph (c) of this section, the employer must ensure that personal fall arrest systems: <ul style="list-style-type: none"> 1910.140(d)(1)(i) Limit the maximum arresting force on the employee to 1,800 pounds (8 kN); 1910.140(d)(1)(ii) Bring the employee to a complete stop and limit the maximum deceleration distance the employee travels to 3.5 feet (1.1 m); 1910.140(d)(1)(iii) Have sufficient strength to withstand twice the potential impact energy of the employee free falling a distance of 6 feet (1.8 m), or the free fall distance permitted by the system; 	PASS

OSHA 1910 & OSHA 1926

The Penetrator X3 Cart (72810) successfully passed a 310 lb. drop test up to 3 consecutive drops. The Penetrator Device (72841) successfully deployed into the substrates. The test weights did not contact the ground or lower structure. See table below for the substrate layers tested.

Part Numbers	Test Material	Max Fall arrest
72810 72841	TPO	3
	2" EPS/ISO Foam	
	1/2" Plywood	
72810 72841	EPDM	3
	2" EPS/ISO Foam	
	1/2" Plywood	
72810 72841	20ga Steel Roof Deck	3
	24ga Steel Roof Deck	
	1/2" Plywood	
72810 72841	1/2" Plywood	3

Penetrator X3 (PN 72810)

- Weight of Cart: 430 lbs.
- Max # of Workers in Fall Arrest: 3
- Minimum setup distance from the leading edge: 8 feet



877-723-3766
info@safetyrailsource.com
www.safetyrailsource.com

404-344-0000
sales@tiedown.com
www.tiedown.com

Tie Down Engineering, Inc.
605 Stoneshill Drive, SW
Atlanta, GA 30336



877-723-3766
info@safetyrailsource.com
www.safetyrailsource.com

404-344-0000
sales@tiedown.com
www.tiedown.com

Tie Down Engineering, Inc.
605 Stoneshill Drive, SW
Atlanta, GA 30336



Inspection Checklist and Maintenance Log



Penetrator X3 Model # _____	Date of Purchase: _____
Serial Number: _____	Purchased From: _____

Cart	Date:								
Frame: Free of Rust?									
Frame: Welded Connections?									
Axles/Wheels Rotate Properly?									
Overall Cart Parts?									

Penetrator X3 Device	Date:								
Frame: Free of Rust?									
Frame: Welded Connections?									
Mounting Pins (2)?									
Penetrator X3 Spikes Free of Damage?									
Spike Guard Shield Present?									
Anchor Shackles and Pins Available (4)?									
Anchor Shackles and Pins Tightened?									
Retaining Slide Bar Clear of Any Obstructions?									
Wing Nut Tightened/Retaining Slide Bar?									
Inner/Outer Spike Tube Engaged?									
(If "Yes" DO NOT USE)									
Pull Pins (5) Secured with Safety Cotter Pin?									
Safety and Warning Labels Readable?									

Date	Corrective Action Taken: