

**E ERECTA STEP®**

**Industrial Stairs Series**



# OWNER'S MANUAL

## Industrial Stairs Series



Safety Rail Source, LLC  
2570 Blvd. of the Generals  
Suite 200  
Norristown, PA 19403  
(877) 723 3766  
[www.safetyrailsource.com](http://www.safetyrailsource.com)

**E ERECTA STEP**

219 Safety Avenue / Andrews, SC 29510 / Ph 888 878 1839 / Fx 843 264 8584

# UNIVERSAL MODULAR PLATFORM SYSTEM

**WARNING! READ CAREFULLY AND UNDERSTAND ALL INSTRUCTIONS BEFORE STARTING INSTALLATION. FAILURE TO FOLLOW ALL INSTRUCTIONS MAY RESULT IN DEATH OR SERIOUS PERSONAL INJURY.**

## IMPORTANT

- Equipment should not be altered or modified from its original design without consultation with the manufacturer.
- Equipment which is damaged or becomes damaged during use, handling, or shipping should be set aside and not used.

 **WARNING!** Failure to anchor unit properly with the correct layout dimensions can result in product damage not covered under warranty – product is not designed to be self supported without anchor bolts. Failure to secure all fasteners may result in death or serious personal injury.

- Do not assemble unit off of anchor bolts and then lift onto them. System should only be assembled in its final location. Never move an assembled system.

 **WARNING!** Backing plates must be used where designated in the instruction manual. Failure to use backing plates where designated may cause equipment to fail and may result in death or serious personal injury.

- **TORQUE DATA:**  
All ½” bolted connections = 678 in lbs. (56 ft lbs.) lubricated or 904 in lbs. (75 ft lbs.) dry +/- 10%.  
For 5/8” anchor bolts = 900 in lbs. (75 ft lbs.) lubricated or 1080 in lbs. (90 ft lbs.) dry +/- 10%.  
Use of impact wrenches NOT sanctioned.

 **WARNING!** After a usage period of 60-90 days, check all fasteners to ensure connections are secure. Periodic inspection is recommended to ensure all fasteners are secured. Failure to secure all fasteners may result in death or serious personal injury.

This product and/or it's components may be covered by one or more patents.

For more information, go to [www.erecastep.com/patents](http://www.erecastep.com/patents)

 **WARNING!** This product can expose you to chemicals including cadmium, which is known to the State of California to cause cancer, and/or birth defector other reproductive harm.

For more information, go to [www.p65warnings.ca.gov](http://www.p65warnings.ca.gov)

**⚠ IMPORTANT ASSEMBLY ALERT**

**SUPPORTED PLATFORM  
PREFERRED STAIR ASSEMBLY PROCEDURE**

STEP 1

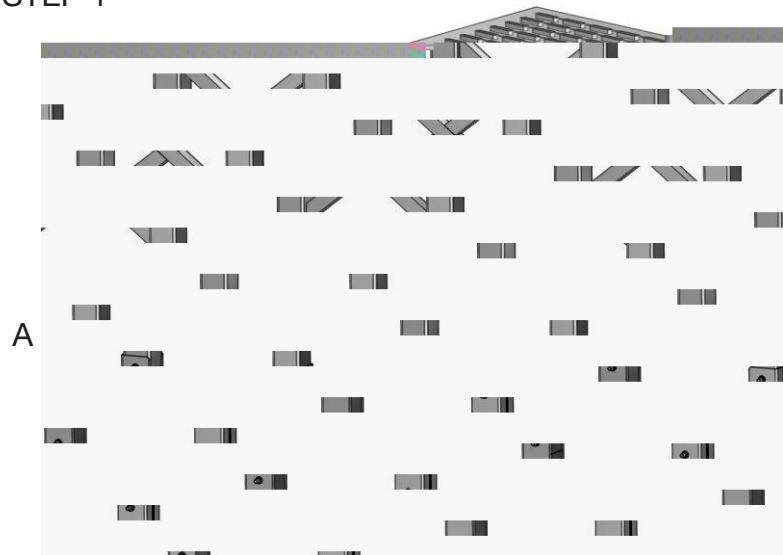

When a platform is being supported by a tower support at the stair location, **the tower should first be located on the anchor bolts and secured in the final assembly location.**

Install the Tower/Platform brackets with the bolts to the tower upper u-bracket hand tight. The platform can then be set on top of the tower and should be supported at both ends. If a tower is not present at the opposite end of the platform (opposite the stairs), then some other means of support **MUST** be applied.

- A)** Position the platform so that the stair mounting surface of the platform is flush with the upper tower u-bracket “A”.
- B)** Torque the bolts “B” between the platform and tower first.
- C)** Next torque the bolts “C” connecting the upper tower u-bracket to the tower/platform brackets.
- D)** Finally torque the bolts “D” connecting the tower/platform brackets to the platform.

Tower/platform brackets are used on units with 3 or more steps.

# SUPPORTED PLATFORM PREFERRED STAIR ASSEMBLY PROCEDURE

## STEP 1

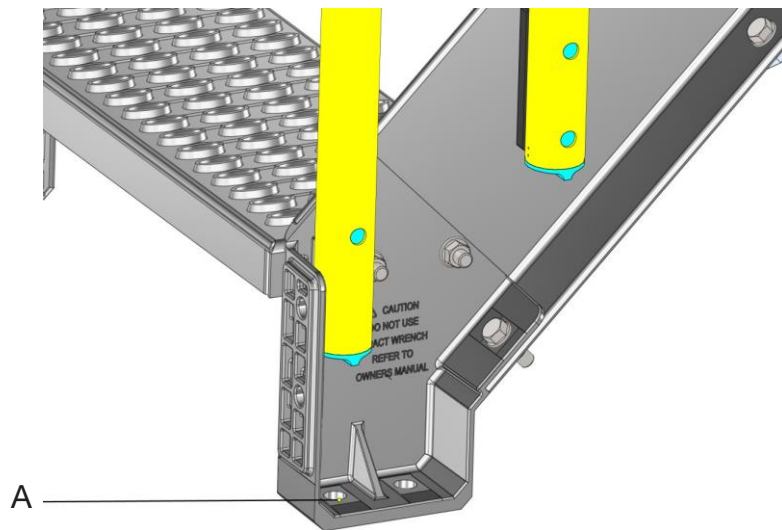

With the stair assembly fully assembled (in this configuration, tower supported) no stair to platform bracket is required. Properly locate the stair unit on the pad layout anchor bolts "A".

- A)** Use the closest hole "A" to the bottom edge of the stairs for standard anchor bolt pad layout. Additional anchor bolt hole towards the platform can be added if additional holding force is required and for systems higher than 6 steps. Start anchor bolt nuts so that the stairs can be adjusted but will not come off of the anchor bolt.
- B)** With pre-installed stair castings bolts in the platform mounting slots, install platform backing plate and nuts "B".
- C)** Check to ensure upper stair casting is flush with platform face. (ref. Step1 page1)

**⚠ IMPORTANT ASSEMBLY ALERT**

**SUPPORTED PLATFORM  
PREFERRED STAIR ASSEMBLY PROCEDURE**

STEP 1

A

With the stair assembly fully assembled, properly locate the stair unit on the pad layout anchor bolts “A”.

B

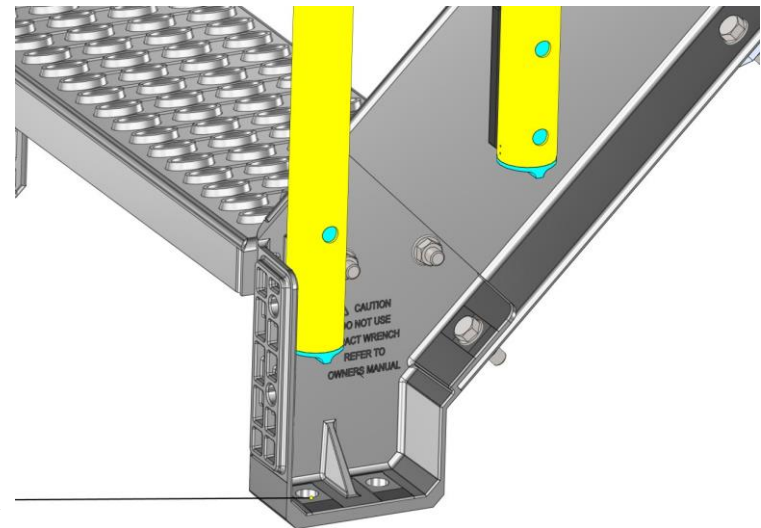

- A)** Use the closest hole “A” to the bottom edge of the stairs for standard anchor bolt pad layout. Additional anchor bolt hole towards the platform can be added if additional holding force is required and for systems higher than 6 steps. Start anchor bolt nuts so that the stairs can be adjusted but will not come off of the anchor bolt.
- B)** Support the stair assembly using forklift, crane, or temporary support (as shown in “B”). Temporary support can be built to stand under one of the highest step treads.
- C)** Height of temporary support can be calculated by multiplying the number of steps by 9”, then subtract 3/8”.

# SUPPORTED PLATFORM

## PREFERRED STAIR ASSEMBLY PROCEDURE

### STEP 2

C

D

B

A

- A)** When fitting the platform to the stairs, care should be taken to make ABSOLUTELY sure the stair bracket, stair casting, and platform mounting surface are flush and in alignment to one another (as seen in “A”).
- B)** First, hand tighten the bolts and nuts “B” connecting the stair/platform bracket to the stair casting.
- C)** Next, with the pre-installed stair casting bolts in the platform mounting slots, install platform backing plate and nuts “C”. These should be hand tightened only.
- D)** Next, hand tighten the bolts and nuts “D” connecting the stair/platform bracket to the platform. Tower/platform brackets are used on units with 3 or more steps.
- E)** Next torque the bolts and nuts “B” ensuring that the bracket is flat and flush to the upper stair casting. Failure to do so will damage the casting.
- F)** Next torque the bolts and nuts “C” (again ensuring that the platform is flat and flush to the upper stair casting). Failure to do so will damage the casting.
- G)** Finally, torque bolts and nuts “D”. Tower/platform brackets are used on units with 3 or more steps.

# UNIVERSAL MODULAR PLATFORM SYSTEM

## ASSEMBLY CRITERIA

Verify proper installation according to ErectaStep installation manual. In addition, make sure to check the following:

- Ensure all anchor bolts are installed properly at the stair base and tower.
- Ensure leading edge of platform and stair gusset are flush.
- Ensure tower is vertically plumb.
- Ensure all bolts are properly tightened according to ErectaStep installation manual.
  - Tighten all bolts by hand. No impact wrenches are to be used.
- Ensure that stair guardrail posts are vertically plumb.

# UNIVERSAL MODULAR PLATFORM SYSTEM

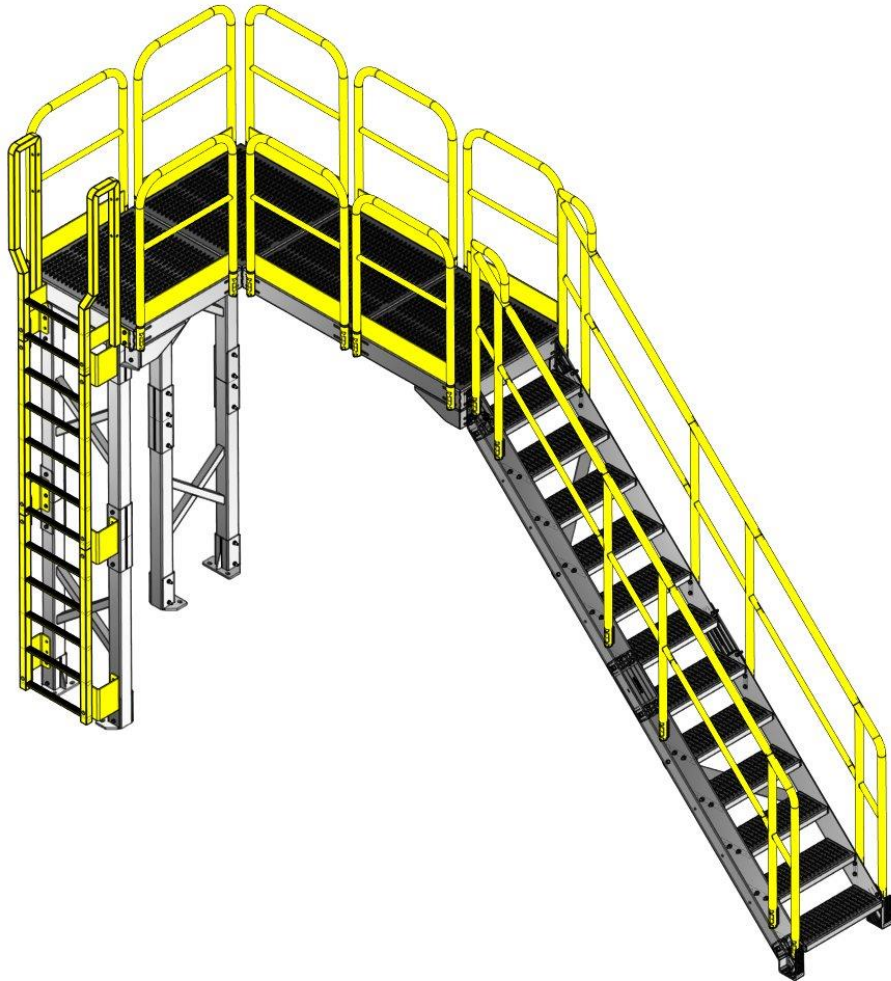

## INTRODUCTION:

ErectaStep modular platform and stair systems are pre-engineered and designed for unlimited configurations. This universal design allows for optimum flexibility to gain access and egress over and/or around obstructions, equipment, walls, etc.

ErectaStep uses only the highest quality material in the construction of its modular system to ensure the quality, strength, and dependability for years. It is very important to follow configuration guidelines and installation instructions for your ErectaStep system. Design limitations can exist with respect to required supports, adequate footings, and prescribed application.



# COMPONENTS

Universal Platforms

Stair Units  
(Base & Extension)

Tower Supports  
(Base & Extension)

- Minimum of 2 people are recommended for assembly.
- Forklift or crane may be required based on height and complexity of assembly configuration.

Ladders  
(Base & Extension)

Handrails

# SYSTEM ANCHOR LAYOUT

PLAN VIEW

PAD LAYOUT

## ANCHOR BOLT POSITION

Verify proper installation according to ErectaStep installation manual. In addition, make sure to check the following:

- Anchor bolt positions should be laid out by mathematically calculating positions of anchors. (See component anchor layout or ErectaStep configurator pad layout for your system.)
- **NOTICE:** Four anchor bolts are required on units with 6 or more steps.
- Layout area for location of your ErectaStep system using measuring tape and chalk lines, keeping anchor lines square and parallel.
- Drill or wet set anchor bolts in the mathematically correct location prior to assembly. Follow any curing procedures recommended by your concrete/anchor bolt supplier.
- Using a level slab/foundation is recommended for anchoring the ErectaStep unit to achieve a good contact point between the bottom of the stairs/supports and the concrete in lieu of utilizing leveling anchors and shims.
- Once pad layout is complete and you are ready to assemble unit, continue with instructions. Assemble unit on anchor bolts starting with supports and stairs. Then connect platforms, handrails, gussets, etc.
- **NOTICE:** Do not assemble unit off of anchor bolts and then lift onto them. System should only be assembled in its final location. Never move an assembled system.

# COMPONENT ANCHOR LAYOUT

## Stair Unit

5/8" diameter anchor bolts required for 3/4" diameter holes in base plate.

Two (2) anchor bolts required for units less than 6 steps.

Four (4) anchor bolts required per stair unit for units with 6 or more stairs.

## Dimensions:

$$A = (\# \text{ of step} \times 9") + 9"$$

$$B = (\# \text{ of step} \times 9") + 1/2"$$

## Tower Supports

5/8" diameter anchor bolts required for 3/4" x 1 1/4" slots in base plate.

Four (4) anchors required per tower.

SECTION A-A

SECTION B-B

# STACKING COMBINATIONS

## Stacking:

Towers, ladders, and stairs with 3 - 6 stairs can be stacked to create systems greater than 6 steps high. See samples below:

7 step = 4 step + 3 step

8 step = 5 step + 3 step  
= 4 step + 4 step

9 step = 5 step + 4 step

12 step = 6 step + 6 step  
= 4 step + 4 step + 4 step

It is recommended that larger sections be positioned at the bottom of stacked sections.



### **WARNING!**

15 steps is maximum size without special stair rules. For 16 - 20 step systems, see ErectaStep configurator or sales representative. Failure to adhere to special stair rules may result in death or serious injury.

**NOTICE:** One and two step towers, ladders and stairs are not used in stacking.

# PLATFORM SLOT USAGE

Platforms are designed with slots to allow for adjusting positions of handrails and stair units.

**CAUTION!** Certain configurations can create pinch points.

Platform slot design allows for mounting adjustments to deter pinch points.

Handrails or stair units can make use of these slots in order to avoid pinch points.

**NOTICE:** Be sure to account for dimensional change in anchor bolt layout when sliding stair unit over.

# TOWER BASE COMPONENTS

## 1 - 2 STEP

### TOWER BASE ORDER NUMBERS

1 step – Part #90011B

2 step – Part #90012B

Hardware kit for 1 or 2 Step  
Part #55996

**NOTICE:** 1 and 2 step can not be  
used when stacking towers.

# TOWER BASE COMPONENTS

## 3 - 6 STEP

ES TOWER HARDWARE  
Kit – 3 - 6 – 55997

ES TOWER-PLT BRACKET  
RIGHT – 54302

ES TOWER-TOP  
U BRACKET WELD – 52558

ES TOWER-TOP  
HORZ TUBE – 52557

ES TOWER-PLT BRACKET  
LEFT – 54303

ES TOWER-WELDMENT  
6 STEP – 54306

ES TOWER-BASE  
WELDMENT – 52559

### TOWER BASE ORDER NUMBERS

3 step – Part #90013B  
4 step – Part #90014B  
5 step – Part #90015B  
6 step – Part #90016B

Some components may  
ship pre-assembled.

# TOWER EXTENSION COMPONENTS

## 3 THRU 6 STEP

ES TOWER-MID  
U-BRACKET – 52556

ES TOWER- WELDMENT  
6 STEP – 54306

Some components may  
ship pre-assembled.

### TOWER EXTENSION ORDER NUMBERS

3 step – Part #90013X  
4 step – Part #90014X  
5 step – Part #90015X  
6 step – Part #90016X

### ES TOWER EXTENSION HARDWARE

Kit – 3 - 6 – Part#72300



# TOWER INSTRUCTIONS

## SINGLE / STACKED

Single  
Configuration

Stacked  
Configuration

# TOWER INSTRUCTIONS – BASE

## 3 - 6 STEP

STEP 1: Orient components as shown.

STEP 2: Attach hardware as shown and tighten hardware.

**NOTICE:** Some components may ship pre-assembled. Disassemble base from tower if used as middle or upper section when stacking.

# TOWER INSTRUCTIONS – TOP MEMBER

## 3 - 6 STEP

STEP 3: Orient components as shown.

STEP 4: Attach hardware and tighten as shown.

**NOTICE:** Some components may ship pre-assembled. Disassemble top member from tower if used as middle or lower section of stacking.

# TOWER INSTRUCTIONS – TOP BRACKETS

## 3 - 6 STEP

STEP 5: Orient components  
and add as shown.

STEP 6: Tighten  
hardware.

# TOWER INSTRUCTIONS – STACKED SECTION

## 3 - 6 STEP

STEP 1: Orient components needed for the desired tower height.

STEP 2: At each stacked section joint, attach brackets and add hardware as shown and tighten hardware.

See previous sheets for instruction on base, top member, and top bracket connections.

**NOTICE:** If ladder assembly is to be attached to the tower, this should be done at this time prior to installation at final anchor location for ease of installation.

# TOWER/PLATFORM CONNECTIONS

Flush bolting arrangement used when supporting one platform.

Split bolting arrangement used when supporting two platforms (tower located at joint between platforms).

## BOLTING DIAGRAM

Flush bolting (shown) uses outside set of holes in tower.

Split bolting uses inside set of holes in tower.

**NOTICE:** Bolt orientation should be with bolt head up.

**NOTE:** Tower/platform brackets used on units with 3 or more steps.

# TOWER/PLATFORM CONNECTIONS

OMIT  
HARDWARE  
FROM THESE  
HOLES

When tower and stairs are both used at the end of a platform, omit indicated hardware from tower assembly. These bolts will interfere with top step of stair unit.

Tower base plate and top cross member are slotted. Slide the tower as indicated to allow for flush mount of the stair unit to the platform.

**NOTICE:** Stair unit brackets will not be used in this configuration.

# LADDER/TOWER BASE COMPONENTS

## 1 AND 2 STEP

ES LADDER UPPER  
SECTION WELD

ES LADDER UPPER  
SECTION WELD

ES LADDER  
BRACKETS

ES LADDER  
BRACKETS

ES LADDER SPACER  
SECTION WELD

### LADDER/TOWER ORDER NUMBERS

1 step – Part #90031B  
2 step – Part #90032B  
(These part numbers include tower  
components shown.)

### HARDWARE KIT FOR

1 or 2 Step – Part #55988

**NOTICE:** 1 and 2 steps can not be  
used when stacking ladders.



# LADDER/TOWER BASE COMPONENTS

## 3 - 6 STEP

ES LADDER UPPER  
SECTION WELD

ES LADDER  
SECT 6 STEP WELD

ES LADDER  
BRACKETS

### LADDER/TOWER ORDER NUMBERS

3 step – Part #90033B

4 step – Part #90034B

5 step – Part #90035B

6 step – Part #90036B

(These part numbers include  
tower components shown.)

### HARDWARE KIT FOR

3 - 6 Step – Part #55995

See tower instructions for tower  
section of ladder/tower unit.

# LADDER/TOWER EXTENSION COMPONENTS

## 3 - 6 STEP

ES LADDER  
SECT 6 STEP  
WELD

ES LADDER  
SPACER  
SECTION WELD

ES LADDER  
BRACKETS

### LADDER/TOWER ORDER NUMBERS

3 step – Part #90033X

4 step – Part #90034X

5 step – Part #90035X

6 step – Part #90036X

(These part numbers include  
tower components shown.)

### HARDWARE KIT FOR

3 - 6 Step – Part #55995

See tower instructions for tower  
section of ladder/tower unit.

### ES LADDER EXTENSION HARDWARE KIT

3 - 6 – Part #723732

# LADDER INSTRUCTIONS

## LADDER CONFIGURATION 3 - 6 STEP ASSEMBLY

**NOTICE:** Mount ladder to tower during tower assembly prior to setting towers for ease of installation.

### STEP 1

Orient components as shown for non stacked sections (3 - 6 step). Use carriage bolts and nuts to attach ladder sections to each other using ladder bracket.

**NOTE:** Holes of ladder bracket orient towards ladder. Slots of ladder bracket orient towards tower.

**IMPORTANT:** Before attaching ladder brackets, brackets must be aligned using holes and slots to both tower bolts and ladder section holes (see next page). A ladder bracket must be used to join each section of ladder.



UPPER SECTION  
WELD ALWAYS  
USES 3 RD HOLE  
FROM TOP AND  
BOTTOM HOLE ON  
LADDER BRACKET

# LADDER/TOWER INSTRUCTIONS

## LADDER CONFIGURATION 3 - 6 STEP ASSEMBLY

### STEP 2:

Attach assembled ladder to tower as shown. Upper hardware will attach to platform. Tighten hardware both sides of ladder (only one side shown).

**NOTICE:** Ladder step size must match tower size in order for mounting holes to line up.

**NOTICE:** Backing plates supplied with platform.



**WARNING!** Backing plate must be used at this connection. Failure to use backing plates may cause equipment to fail and may result in death or serious personal injury.

# LADDER INSTRUCTIONS

## LADDER CONFIGURATION STACKED ASSEMBLIES (GREATER THAN 6 STEP)

**NOTICE:** Mount ladder to tower during tower assembly prior to setting towers for ease of installation.

### STEP 1

Orient components as shown for stacked sections (greater than 6 step). Use carriage bolts and nuts to attach ladder sections to each other using ladder bracket.

**NOTE:** Holes of ladder bracket orient towards ladder. Slots of ladder bracket orient towards tower.

**IMPORTANT:** Before attaching ladder brackets, brackets must be aligned using holes and slots to both tower bolts and ladder section holes (see next page). A ladder bracket must be used to join each section of ladder.



UPPER SECTION WELD ALWAYS USES 3rd HOLE FROM TOP AND BOTTOM HOLE ON LADDER BRACKET

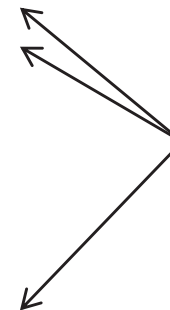

ALL OTHER LADDER BRACKETS WILL USE HOLES BASED ON TOWER BOLT LOCATION TO LADDER SPLICE LOCATION

# LADDER INSTRUCTIONS

## LADDER CONFIGURATION STACKED ASSEMBLIES (GREATER THAN 6 STEP)

### STEP 2

Attach assembled ladder to tower as shown. Upper hardware will attach to platform. Tighten hardware both sides of ladder (only one side shown).

**NOTICE:** Ladder step size configuration must match tower size configuration in order for mounting holes to line up.

Example: If tower is configured as 6 step on bottom and 4 step on top, then lower unit of ladder must be 6 step and upper unit of ladder must be a 4 step.

**NOTICE:** Backing plates supplied with platform.



**WARNING!** Backing plate must be used at this connection. Failure to use backing plates may cause equipment to fail and may result in death or serious personal injury.

# LADDER/TOWER INSTRUCTIONS

## LADDER CONFIGURATION STACKED ASSEMBLIES (GREATER THAN 6 STEP)

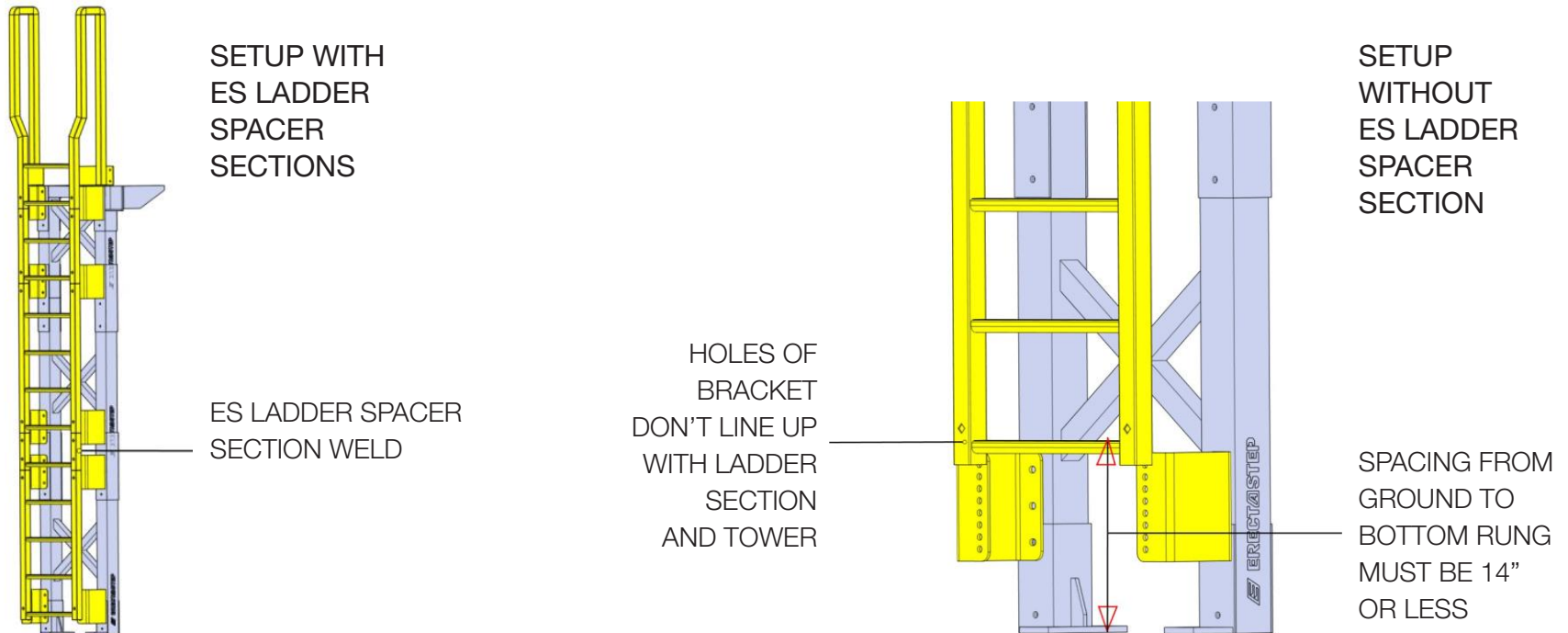

**NOTE:** ES ladder spacer section should be located between ladder sections as need to have brackets located at tower bolt holes.

**IMPORTANT:** Due to ladder rung spacing of 10" and tower/stair heights based on 9" spacing, some configurations will require use of "ES LADDER SPACER SECTION" between ladder sections in order to meet two criteria:

- 1) Ladder brackets must align to use tower bolts while still connecting ladder sections to one another.
- 2) Dimension from ground to bottom rung to be no more than 14".

# LADDER/TOWER INSTRUCTIONS

## LADDER CONFIGURATION STACKED ASSEMBLIES (GREATER THAN 6 STEPS)

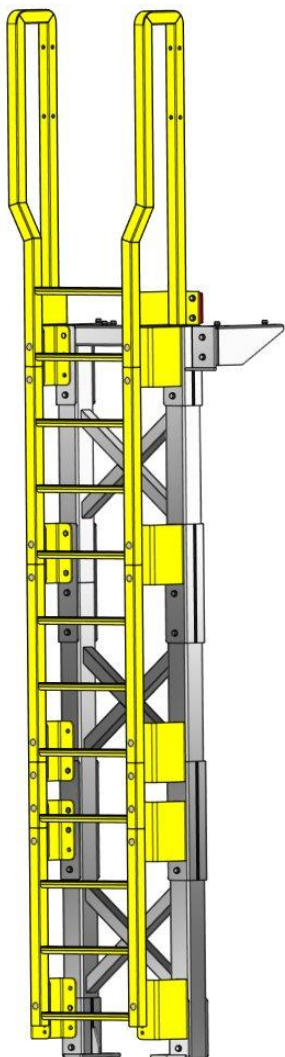

### NUMBER OF ES LADDER SPACER SECTIONS REQUIRED:

#### Example 1–12 Step System

#### Tower Stack

(4) 3 Step Tower Sections,  
 Ground to Platform Distance =  
 $(12 \times 9") + 9" = 117"$  (see sheet 10)

#### Ladder Stack

(4) 3 Step Ladder Section +  
 (1) Upper Section  
 Calculate # of Rungs =  
 $4 \times 2 + 2 = 10$  rungs  
 (see # of Rungs per Section above)  
 Rung spacing is 10", therefore  
 $10 \text{ rungs} \times 10" = 100"$

#### Number of Spacers

Tower Stack minus Ladder Stack =  
 $117" - 100" = 17"$   
 Number of Spacers Required =  
 $17"/10" = 1.7$  (round down to 1)

#### RUNGS PER SECTION

Ladder Section	# of Rungs
ES Upper	2
ES 3 Step	2
ES 4 Step	3
ES 5 Step	4
ES 6 Step	5
ES Spacer	1

**NOTICE:** It is recommended to use as few sections as possible when stacking tower and ladder.



# LADDER/TOWER INSTRUCTIONS

## LADDER CONFIGURATION STACKED ASSEMBLIES (GREATER THAN 6 STEPS)

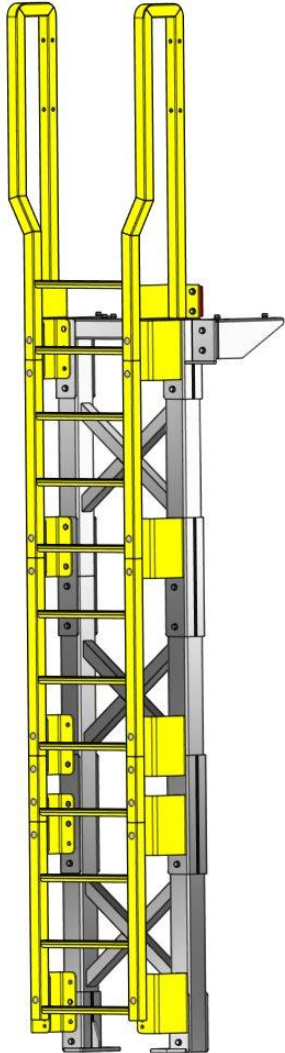

### NUMBER OF ES LADDER SPACER SECTIONS REQUIRED: Example 1–12 Step System

#### Tower Stack

(4) 3 Step Tower Sections,  
Ground to Platform Distance =  
 $(12 \times 9") + 9" = 117"$  (see sheet 10)

#### Ladder Stack

(4) 3 Step Ladder Section +  
(1) Upper Section  
Calculate # of Rungs =  
 $4 \times 2 + 2 = 10$  rungs  
(see # of Rungs per Section above)  
Rung spacing is 10", therefore  
 $10 \text{ rungs} \times 10" = 100"$

#### Number of Spacers

Tower Stack minus Ladder Stack =  
 $117" - 120" = 3"$   
Negative number means ground to first  
rung is less than 10" =  $10" - 3" = 7"$

#### RUNGS PER SECTION

Ladder Section	# of Rungs
ES Upper	2
ES 3 Step	2
ES 4 Step	3
ES 5 Step	4
ES 6 Step	5
ES Spacer	1

**NOTICE:** It is recommended to use as few sections as possible when stacking tower and ladder.

# STAIR BASE COMPONENTS

## 1 AND 2 STEP

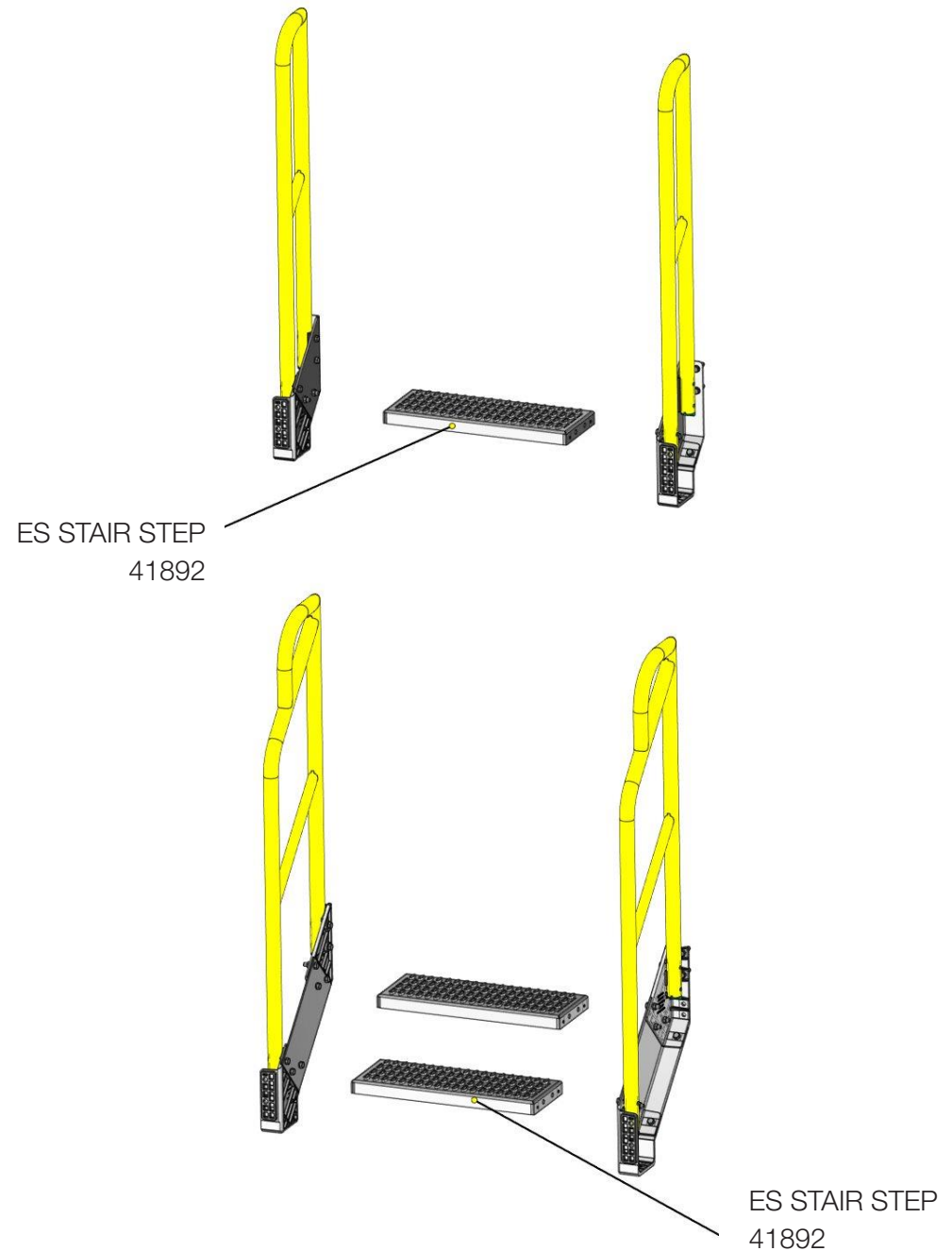

### STAIR ORDER NUMBERS

1 step – Part #90001B

2 step – Part #90002B

**NOTICE:** 1 and 2 steps not used when stacking stairs.

# STAIR BASE COMPONENTS

## 3 - 6 STEP

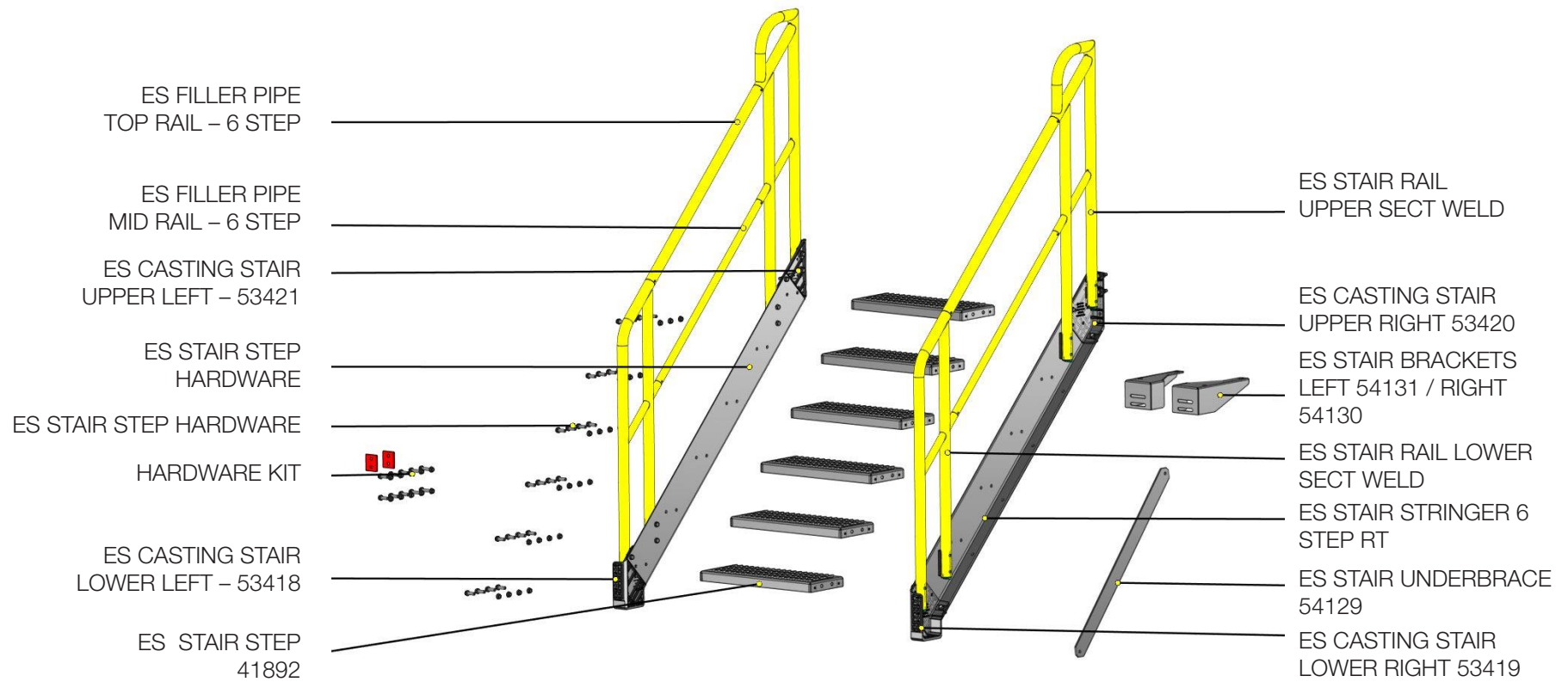

### STAIR ORDER NUMBERS

- 3 step - Part #90003B
- 4 step - Part #90004B
- 5 step - Part #90005B
- 6 step - Part #90006B

### HARDWARE KIT FOR

- 3 - 6 Step - Part #56000

# STAIR EXTENSION COMPONENTS

## 3 - 6 STEP

### ES STAIR EXTENSION HARDWARE KIT

3 - 6 – Part#56001

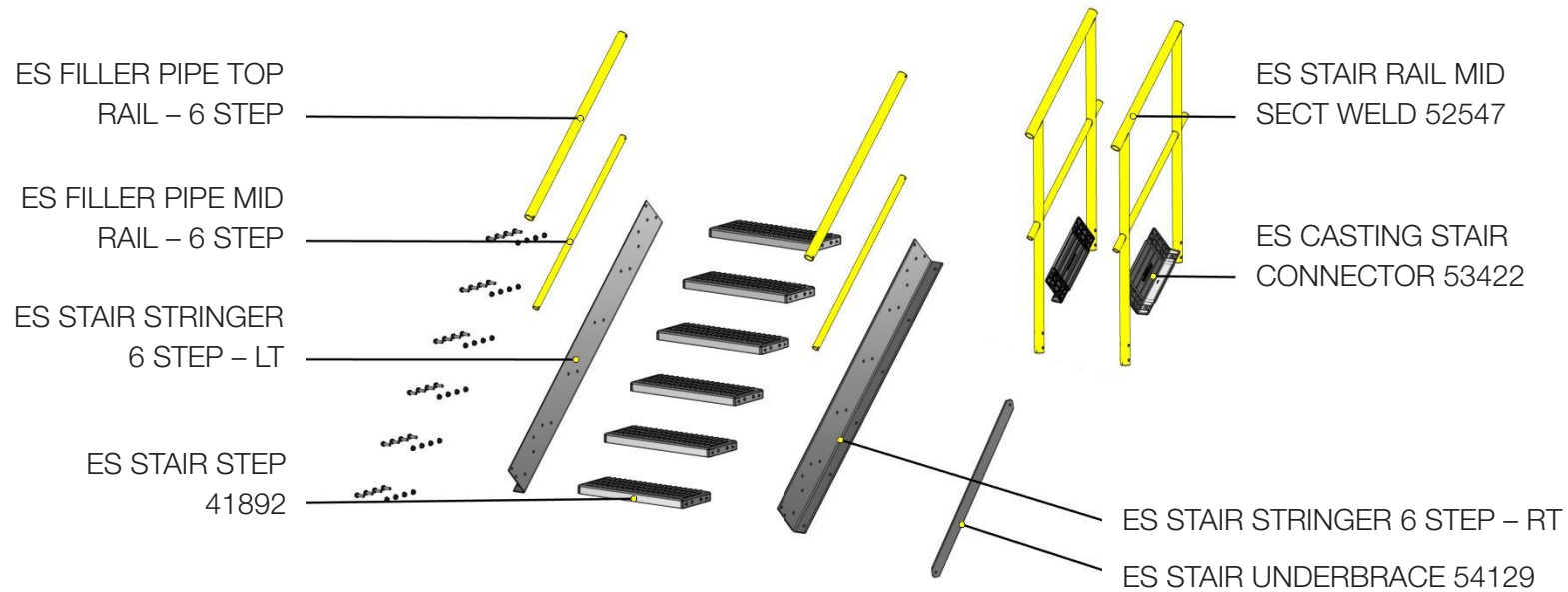

### STAIR ORDER NUMBERS

- 3 step – Part #90003X
- 4 step – Part #90004X
- 5 step – Part #90005X
- 6 step – Part #90006X

### HARDWARE KIT FOR

3 - 6 Step – Part #56000

# STAIR RAIL INSTRUCTIONS

## 3 - 6 STEP

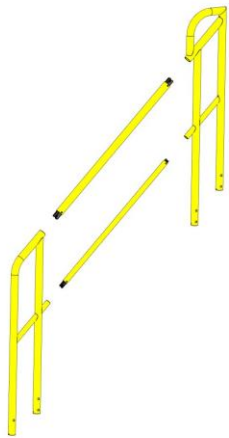

STEP 1  
Orient components  
as shown.

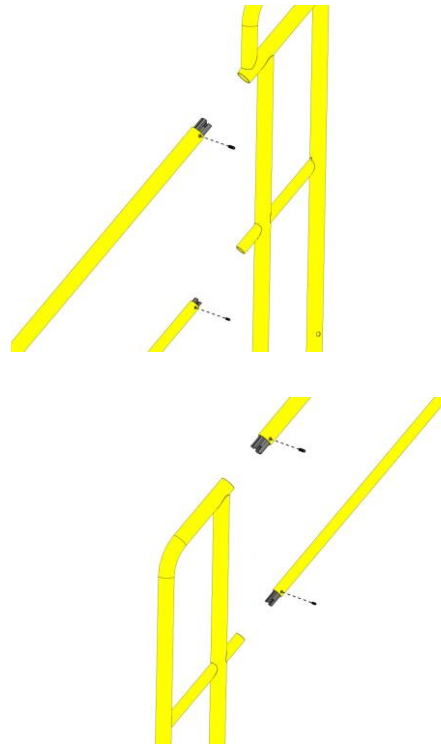

STEP 2  
Insert pipe couplers into the  
filler pipes. Insert coupler set  
screw and loosely tighten.

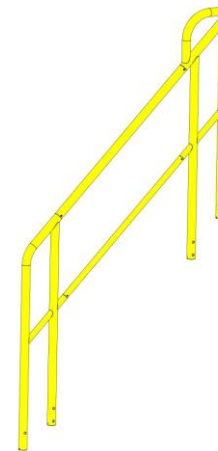

STEP 3  
Slide all components  
together, then securely  
tighten coupler set screw.

# STAIR STRINGER INSTRUCTIONS

## 3 - 6 STEP

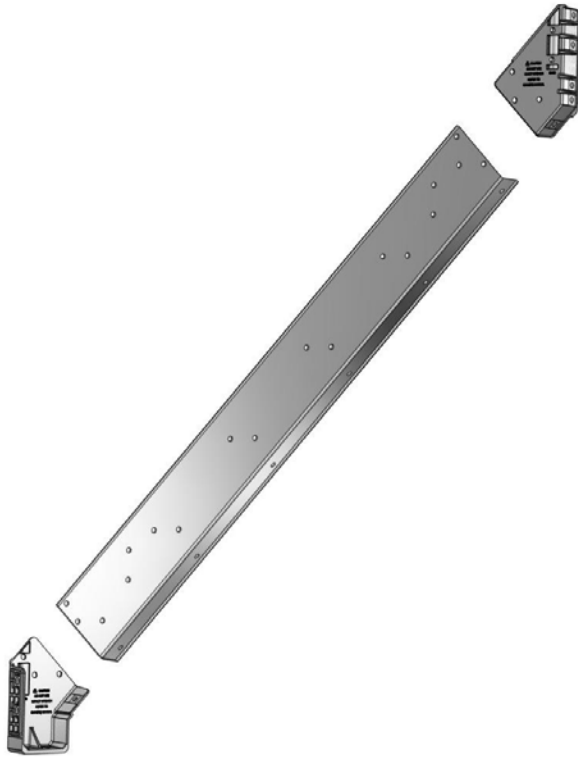

**STEP 1**  
Orient components as shown.

Some components may ship pre-assembled.



**STEP 2**  
Insert and securely tighten hardware (see next sheet for detailed views).

**⚠ WARNING!** Do not use impact wrench. May cause damage to unit which could result in serious personal injury or death. See torque data.

# STAIR STRINGER INSTRUCTIONS

## 3 - 6 STEP

HOLES FOR BOLTING  
STAIR HANDRAILS

HOLES FOR BOLTING  
STAIR STEPS

HARDWARE FOR  
STRINGER ASSEMBLY

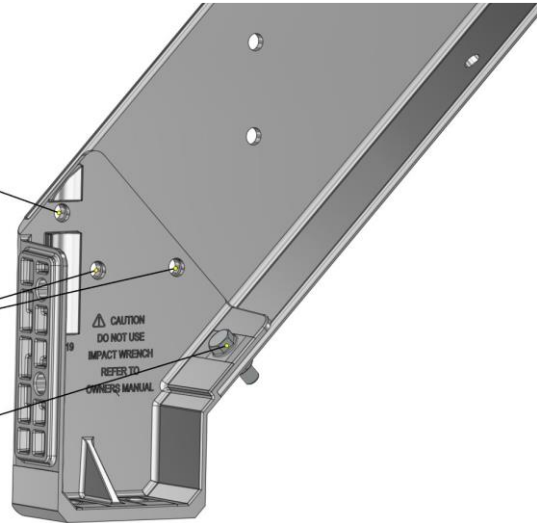

**NOTICE:** Some holes are used both to connect casting to stringer and stair steps and/or handrails.

Platform hardware must be inserted prior to installing stair handrails.



**WARNING!** Do not use impact wrench. May cause damage to unit which could result in serious personal injury or death. See torque data.

HOLES FOR BOLTING  
STAIR HANDRAILS

HOLES FOR BOLTING  
STAIR STEPS

HOLES FOR BOLTING  
TO PLATFORM

HARDWARE FOR  
STRINGER ASSEMBLY

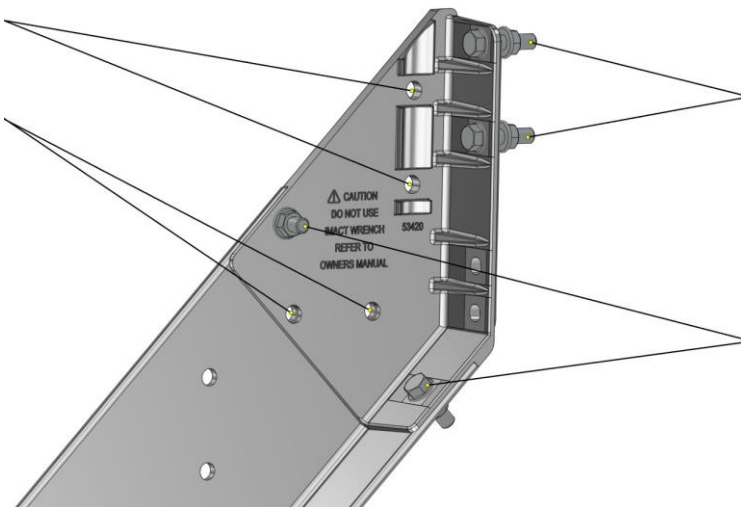

# STRINGER/STAIR RAIL INSTRUCTIONS

## 3 - 6 STEP

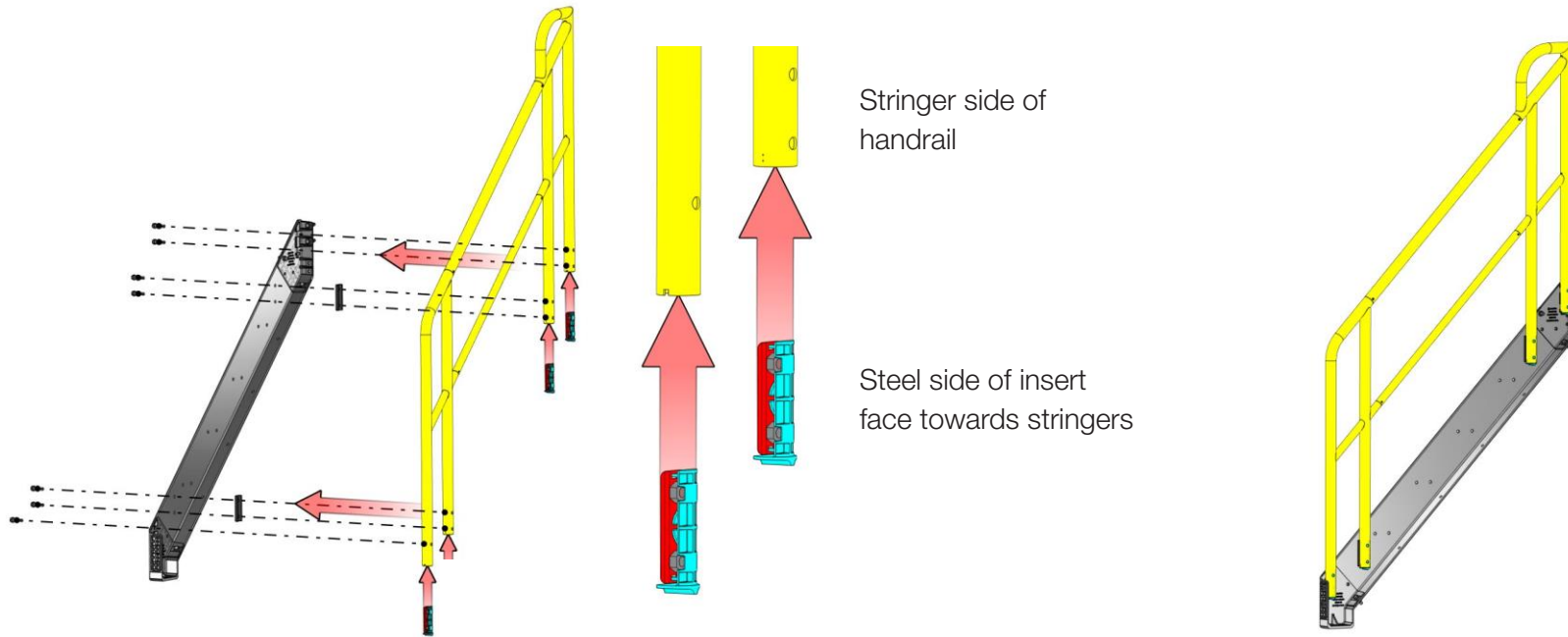

Some components may ship pre-assembled.

**!** **WARNING!** Do not use impact wrench. May cause damage to unit which could result in serious personal injury or death. See torque data.

**STEP 1**  
Slide rail insert into stair handrails. Orient steel side towards stringer. (May require tape to hold in place while assembling).

**STEP 2**  
Position stair handrails onto stringer with handrail spacers (spacers are only required at stringer connection – castings have spacer incorporated.)

**STEP 3**  
Insert hardware and tighten hardware.



# STAIR UNIT INSTRUCTIONS

## 1 - 6 STEP

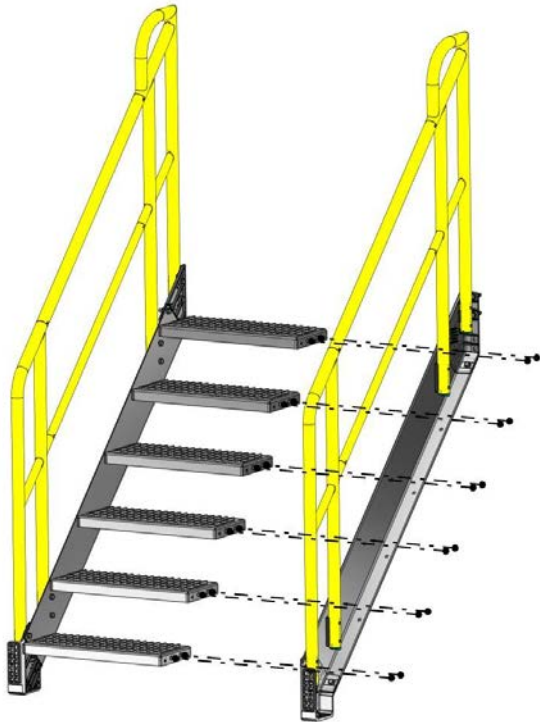

STEP 1  
Orient left and right stringer assembly sections as shown and bolt in all steps.

STEP 2  
Securely tighten all step hardware.

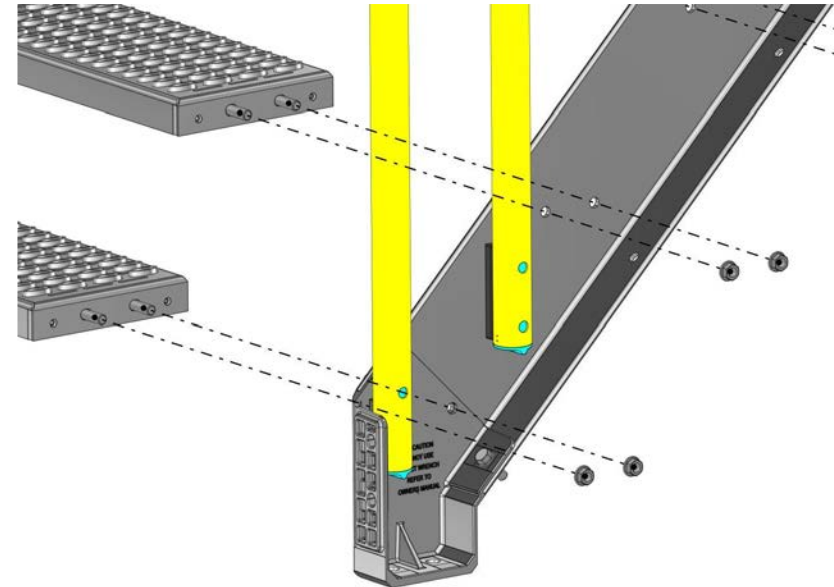

**⚠ WARNING!** Do not use impact wrench. May cause damage to unit which could result in serious personal injury or death. See torque data.

# STAIR UNIT INSTRUCTIONS

## 3 - 6 STEP

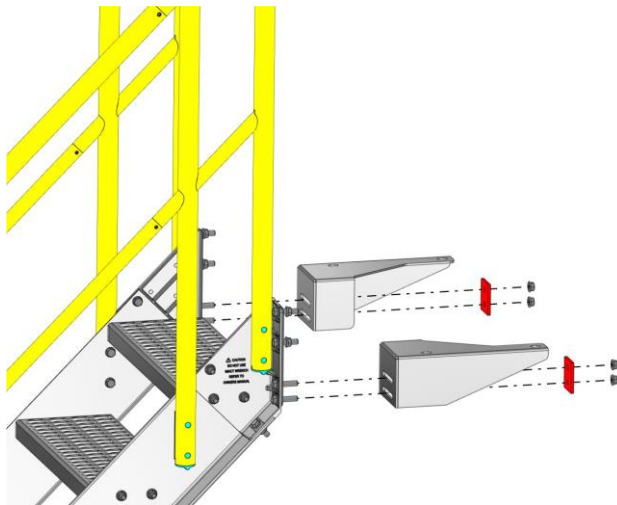

### STEP 3

Attach both left and right brackets with backing plate as shown and securely tighten hardware.

### STEP 4

Attach cross brace under stairs as shown and securely tighten hardware. Position of cross brace should be in middle of stringer.

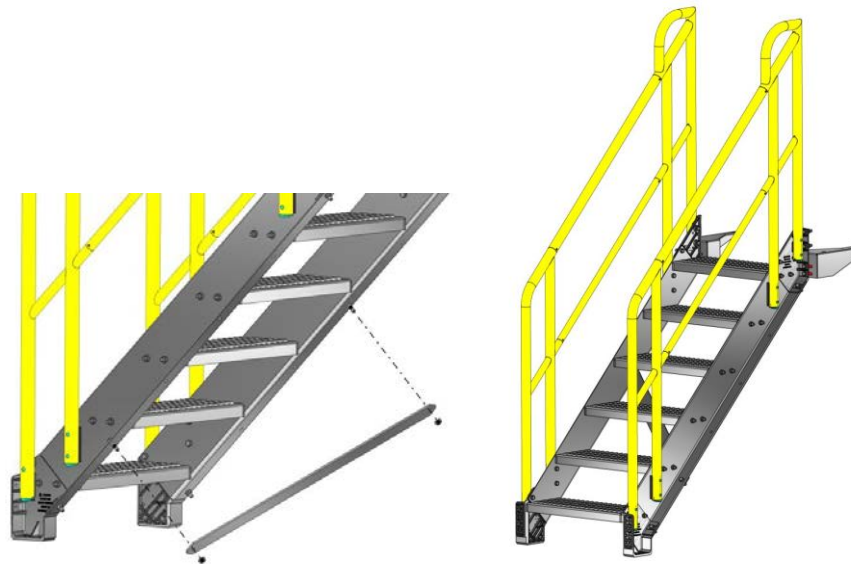

**WARNING!** Do not use impact wrench. May cause damage to unit which could result in serious personal injury or death. See torque data.

**NOTICE:** The hardware orientation for stair cross braces should be installed with bolt head down to avoid injury when accessing under stair unit.

# STAIR UNIT INSTRUCTIONS

## STAIR CONFIGURATION STACKED ASSEMBLIES (GREATER THAN 6 STEP)

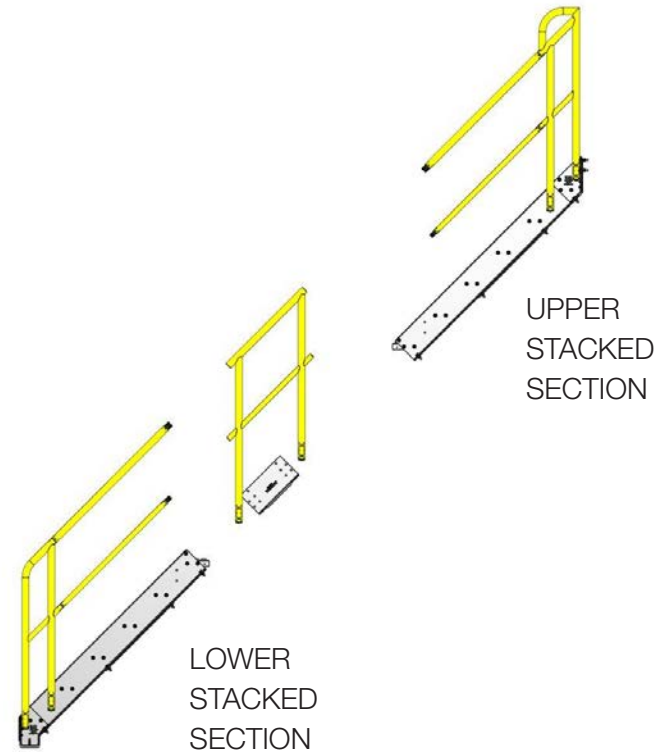
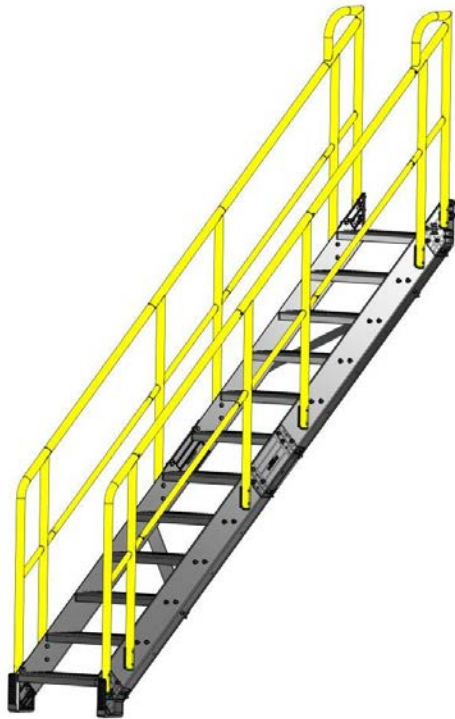

When stacking stair units, stringer and stair handrails are connected using the stair rail mid-section and the casting stair connector between each stacked section.

Crossbrace under stairs should alternate direction from one stacked section to another.

**NOTICE:** Follow all instructions for the 3 - 6 step units.

# PLATFORM COMPONENTS



PLATFORM



PLATFORM  
BACKING PLATE

## PLATFORM ORDER NUMBER

Platform – Part #11394

## HARDWARE KIT FOR

3 - 6 Step – Part #56003

# PLATFORM CONNECTIONS

## PLATFORM TO PLATFORM

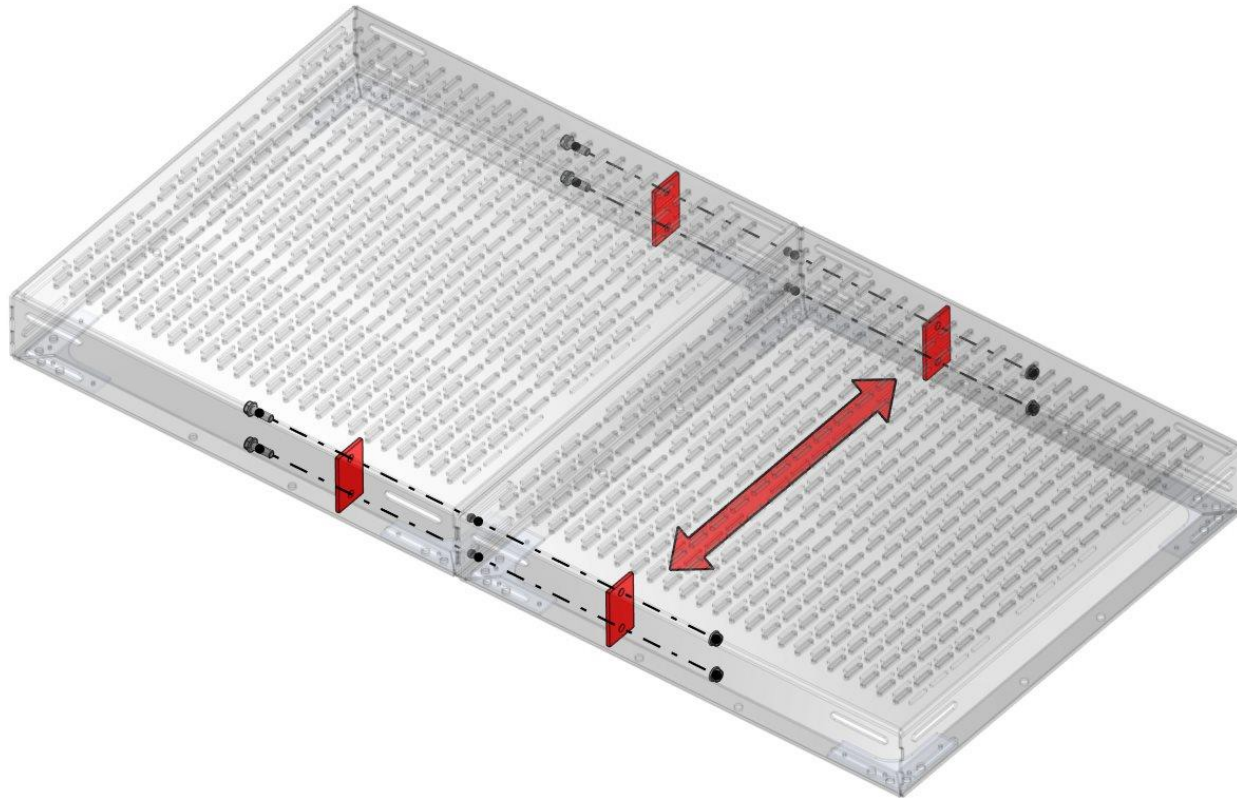

STEP 1  
Align platforms as shown.

STEP 2  
Insert hardware and tighten securely as shown.

**WARNING!** Backing plate must be used at this connection. Failure to use backing plates may cause equipment to fail and may result in death or serious personal injury.

Position backing plates as close to platform corners as possible.

**NOTICE:** No more than 3 platforms can be connected without supports

**WARNING!** Do not use impact wrench. May cause damage to unit which could result in serious personal injury or death. See torque data.

# PLATFORM COMPONENTS

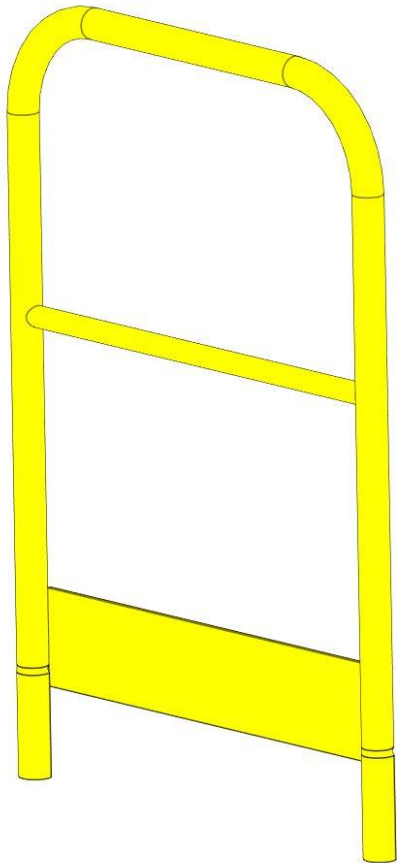

PLATFORM HANDRAIL  
(ES PLATFORM HANDRAIL)

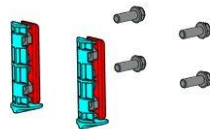

PLATFORM  
HANDRAIL BOLT KIT

PLATFORM HANDRAIL  
ORDER NUMBER

Platform Handrail – Part #55574

HARDWARE KIT FOR

Platform Handrail – Part #56004

# PLATFORM CONNECTIONS

## HANDRAIL TO PLATFORM

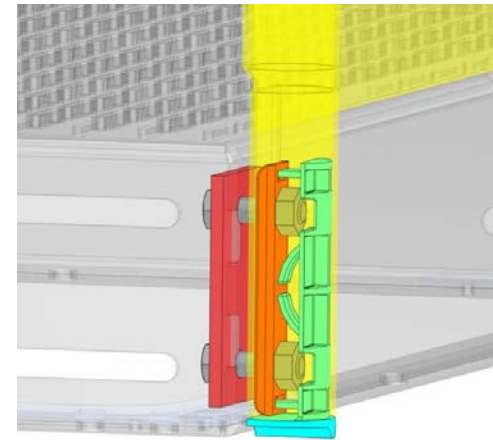
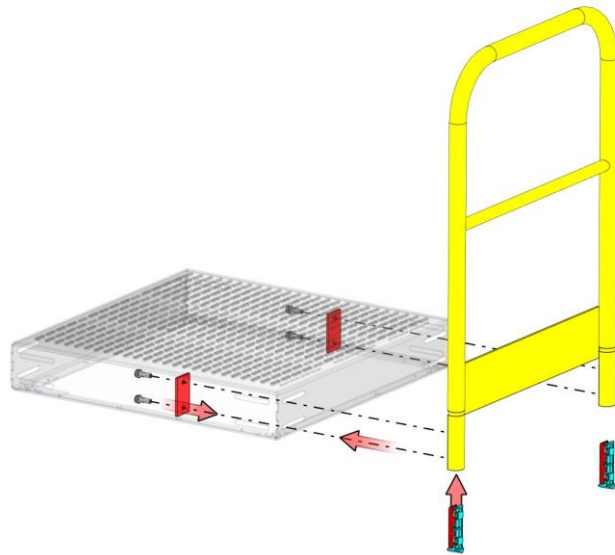

**NOTICE:** Metal piece should be oriented so that nuts are facing plastic.

**STEP 1**  
Slide rail insert into handrails. Orient steel side towards platform. May require tape to hold in place while assembling.

**STEP 2**  
Position handrails onto platform as shown.

**STEP 3**  
Insert hardware and tighten hardware.

**WARNING!** Backing plate must be used at this connection. Failure to use backing plates may cause equipment to fail and may result in death or serious personal injury.

**WARNING!** Do not use impact wrench. May cause damage to unit which could result in serious personal injury or death. See torque data.

# PLATFORM CONNECTIONS

## STAIRS TO PLATFORM

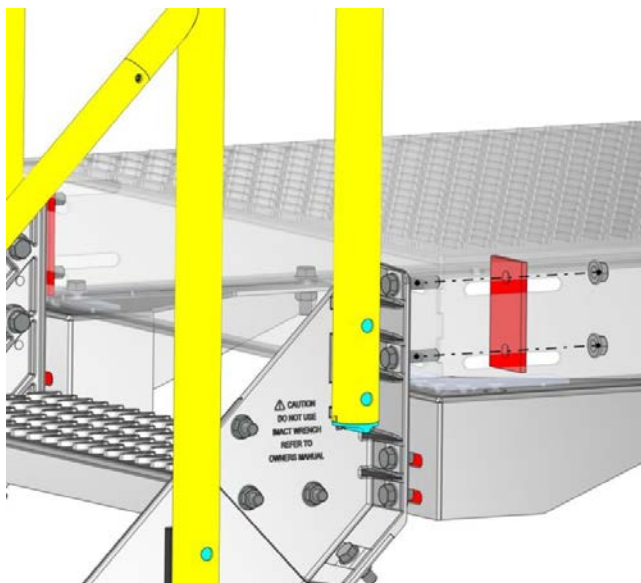

### STEP 1

Position platform and stairs as shown. Connect vertical face of stairs to vertical face of platform using bolt inserted during stair stringer instructions. Securely tighten hardware.

**!** **WARNING!** Backing plate must be used at this connection. Failure to use backing plates may cause equipment to fail and may result in death or serious personal injury.

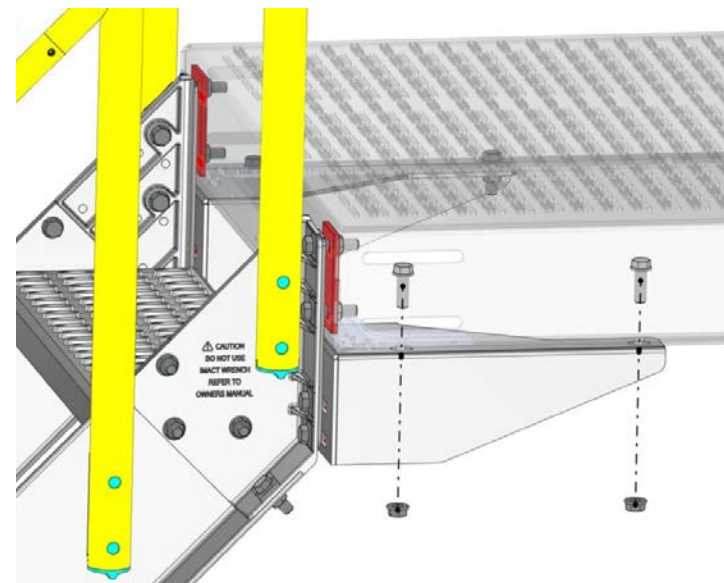

### STEP 2

Connect platform to stair bracket with hardware as shown and securely tighten.

Tower/platform brackets used on 3 step units and taller.

**!** **WARNING!** Do not use impact wrench. May cause damage to unit which could result in serious personal injury or death. See torque data.



## PLATFORM CONNECTIONS

### PLATFORM TO BOTTOM OF STAIRS

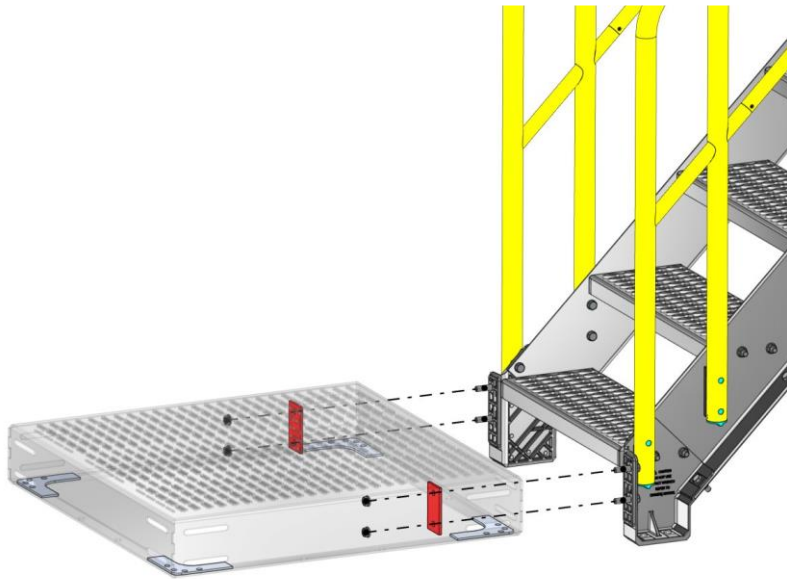

#### STEP 1

Position platform and stairs as shown. Connect using hardware and backing plates as shown. Securely tighten hardware.



**NOTICE:** When using this configuration, bolts used to attach platform to stair must be installed before attaching stair handrails.



**WARNING!** Backing plate must be used at this connection. Failure to use backing plates may cause equipment to fail and may result in death or serious personal injury.



**WARNING!** Do not use impact wrench. May cause damage to unit which could result in serious personal injury or death. See torque data.

# PLATFORM CONNECTIONS

## REMOVABLE HANDRAIL TO PLATFORM

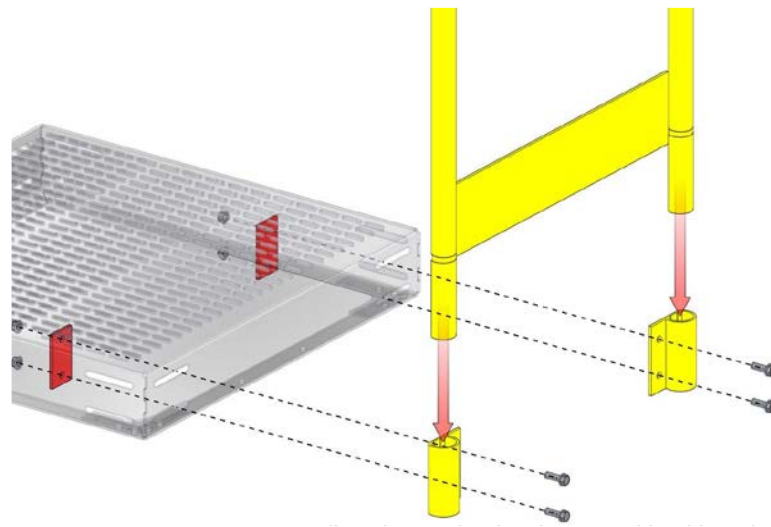

### STEP 1

Loosely attach handrail sockets using hardware and backing plates.

### STEP 2

Slide handrails into sockets for fit and alignment, then tighten hardware.

**NOTICE:** Sockets should be plumb and square to allow handrails to slide in and out.



**WARNING!** Backing plate must be used at this connection. Failure to use backing plates may cause equipment to fail and may result in death or serious personal injury.



**WARNING!** Do not use impact wrench. May cause damage to unit which could result in serious personal injury or death. See torque data.

# HARDWARE CONNECTIONS

## LADDER HARDWARE KIT

1 & 2 step:

Bolt 1/2" x 1 1/2",

Bolt 1/2" x 5 1/2"

Nut 1/2"

Carriage Bolt 1/2" x 3"

3 - 6 step:

Bolt 1/2" x 1 1/2"

Nut 1/2"

Carriage Bolt 1/2" x 3"

## STAIR HARDWARE KIT

1 & 2 step:

3 - 6 step:

Bolt 1/2" x 1 1/2"

Nut 1/2"

Stair bracket backing plate

## STEP HARDWARE KIT

Bolt 1/2" x 1 1/2", Nut 1/2"

## STAIR PRE-ASSEMBLED HARDWARE

Bolt 1/2" x 1 1/2", Nut 1/2", Bolt 1/2" x 2" (stair rail to stringer), 1 1/2" pipe coupling (set screw 3/8" x 1 3/8" Long 3/16" allen wrench), 1" pipe coupling (set screw 5/16" x 7/8" Long 5/32" allen wrench)

## TOWER HARDWARE KIT

1 & 2 step:

Bolt 1/2" x 1 1/2", Nut 1/2"

3 - 6 step:

Bolt 1/2" x 1 1/2", Nut 1/2"

## TOWER PREASSEMBLED HARDWARE

Bolt 1/2" x 5 1/2", Nut 1/2"

# SYSTEM DESIGN

## 1910.29(b)(1)

The top edge height of top rails, or equivalent guardrail system members, are 42 inches (107 cm), plus or minus 3 inches (8 cm), above the walking working surface. The top edge height may exceed 45 inches (114 cm), provided the guardrail system meets all other criteria of paragraph (b) of this section.

## 1910.29(b)(2)(i)

Midrails are installed at a height midway between the top edge of the guardrail system and the walking working surface;

## 1910.29(b)(3)

Guardrail systems are capable of withstanding, without failure, a force of at least 200 pounds (890 N) applied in a downward or outward direction within 2 inches (5 cm) of the top edge, at any point along the top rail.

## 1910.29(b)(4)

When the 200-pound (890-N) test load is applied in a downward direction, the top rail of the guardrail system must not deflect to a height of less than 39 inches (99 cm) above the walking-working surface.

## 1910.29(b)(5)

Midrails, screens, mesh, intermediate vertical members, solid panels, and other equivalent intermediate members are capable of withstanding, without failure, a force of at least 150 pounds (667 N) applied in any downward or outward direction at any point along the intermediate member.

## 1910.29(b)(6)

Guardrail systems are smooth-surfaced to protect employees from injury, such as punctures or lacerations, and to prevent catching or snagging of clothing.

## 1910.29(b)(7)

The ends of top rails and midrails do not overhang the terminal posts, except where the overhang does not pose a projection hazard for employees.

## 1910.29(f)(1)(ii)(B)

The height of stair rail systems installed on or after January 17, 2017 is not less than 42 inches (107 cm) from the leading edge of the stair tread to the top surface of the top rail.

## 1910.29(f)(2)

Finger clearance. The minimum clearance between handrails and any other object is 2.25 inches (5.7 cm).

## 1910.29(f)(3)

Surfaces. Handrails and stair rail systems are smooth-surfaced to protect employees from injury, such as punctures or lacerations, and to prevent catching or snagging of clothing.

## 1910.29(f)(4)

Openings in stair rails. No opening in a stair rail system exceeds 19 inches (48 cm) at its least dimension.

## 1910.29(f)(6)

Projection hazards. The ends of handrails and stair rail systems do not present any projection hazards.

## 1910.29(f)(7)

Strength criteria. Handrails and the top rails of stair rail systems are capable of withstanding, without failure, a force of at least 200 pounds (890 N) applied in any downward or outward direction within 2 inches (5 cm) of any point along the top edge of the rail.

## 1910.29(g)(4)

Platforms used with fixed ladders provide a horizontal surface of at least 24 inches by 30 inches (61 cm by 76 cm).

## 1910.29(k)(1)

The employers must ensure toeboards used for falling object protection:

### 1910.29(k)(1)(i)

Are erected along the exposed edge of the overhead walking-working surface for a length that is sufficient to protect employees below.

### 1910.29(k)(1)(ii)

Have a minimum vertical height of 3.5 inches (9 cm) as measured from the top edge of the toeboard to the level of the walking-working surface.

### 1910.29(k)(1)(iii)

Do not have more than a 0.25-inch (0.5-cm) clearance or opening above the walking-working surface.

## 1910.25(b)(3)

Stairs have uniform riser heights and tread depths between landings;

## 1910.25(b)(4)

Stairway landings and platforms are at least the width of the stair and at least 30 inches (76 cm) in depth, as measured in the direction of travel;

## 1910.25(b)(6)

Each stair can support at least five times the normal anticipated live load, but never less than a concentrated load of 1,000 pounds (454 kg) applied at any point;

## 1910.25(c)

Standard stairs. In addition to paragraph (b) of this section, the employer must ensure standard stairs:

### 1910.25(c)(1)

Are installed at angles between 30 to 50 degrees from the horizontal;

### 1910.25(c)(2)

Have a maximum riser height of 9.5 inches (24 cm);=

### 1910.25(c)(3)

Have a minimum tread depth of 9.5 inches (24 cm); and

### 1910.25(c)(4)

Have a minimum width of 22 inches (56 cm) between vertical barriers (see Figure D-8 of this section).

# SYSTEM DESIGN

## 1910.25(c)(5)

Exception to paragraphs (c)(2) and (3) of this section. The requirements of paragraphs (c)(2) and (3) do not apply to standard stairs installed prior to January 17, 2017. OSHA will deem those stairs in compliance if they meet the dimension requirements specified in Table D-1 of this section or they use a combination that achieves the angle requirements of paragraph (c)(1) of this section.

**Table D-1 Stairway Rise and Tread Dimensions**

Angle to horizontal [mm]	Rise (in inches) [mm]	Tread run (in inches) [mm]
30 deg. 35' [10668mm]	6-1/2 [165mm]	11 [279mm]
32 deg. 08' [2438mm]	6-3/4 [171mm]	10-3/4 [273mm]
33 deg. 41' [12497mm]	7 [178mm]	10-1/2 [267mm]
35 deg. 16' [4877mm]	7-1/4 [184mm]	10-1/4 [260mm]
36 deg. 52' [15850mm]	7-1/2 [191mm]	10 [254mm]
38 deg. 29' [8839mm]	7-3/4 [197mm]	9-3/4 [248mm]
40 deg. 08' [2438mm]	8 [203mm]	9-1/2 [241mm]
41 deg. 44' [13411mm]	8-1/4 [210mm]	9-1/4 [235mm]
43 deg. 22' [6706mm]	8-1/2 [216mm]	9 [229mm]
45 deg. 00' [0mm]	8-3/4 [222mm]	8-3/4 [222mm]
46 deg. 38' [11582mm]	9 [229mm]	8-1/2 [216mm]
48 deg. 16' [4877mm]	9-1/4 [235mm]	8-1/4 [210mm]
49 deg. 54' [16459mm]	9-1/2 [241mm]	8 [203mm]

## 1910.28(b)(11)(ii)

Each flight of stairs having at least 3 treads and at least 4 risers is equipped with stair rail systems and handrails as follows:

**Table D-2 Stairway Handrail Requirements**

Stair width	Enclosed	One open side	Two open sides	With earth built up on both sides
Less than 44 inches (1.1 m)	At least one handrail	One stair rail system with handrail on open side.	One stair rail system with handrail on open side.	One stair rail system with handrail on open side.
44 inches (1.1 m) to 88 inches (2.2 m)	One handrail on each enclosed side	One Stair rail system with handrail on open side and one handrail on enclosed side.	One Stair rail system with handrail on open side and one handrail on enclosed side.	One Stair rail system with handrail on open side and one handrail on enclosed side.
Greater than 88 inches (2.2 m)	One handrail on each enclosed side and one intermediate handrail located in the middle of the stair	One stair rail system with handrail on open side, one handrail on enclosed side, and one intermediate handrail located in the middle of the stair.	One stair rail system with handrail on open side, one handrail on enclosed side, and one intermediate handrail located in the middle of the stair.	One stair rail system with handrail on open side, one handrail on enclosed side, and one intermediate handrail located in the middle of the stair.
Exterior stairs less than 4.4 inches (1.1 m)				

## 1910.144(a)(3)

Yellow. Yellow shall be the basic color for designating caution and for marking physical hazards such as: Striking against, stumbling, falling, tripping, and “caught in between.”

## 1926.451(f)(16)

Platforms shall not deflect more than 1/60 of the span when loaded.

## 1910.23(b)(1)

Ladder rungs, steps, and cleats are parallel, level, and uniformly spaced when the ladder is in position for use;

## 1910.23(b)(2)

Ladder rungs, steps, and cleats are spaced not less than 10 inches (25 cm) and not more than 14 inches (36 cm) apart, as measured between the centerlines of the rungs, cleats, and steps, except that:

## 1910.23(b)(4)

Ladder rungs, steps, and cleats have a minimum clear width of 11.5 inches (29 cm) on portable ladders and 16 inches (41 cm) (measured before installation of ladder safety systems) for fixed ladders

## 1910.23(d)(1)

Fixed ladders are capable of supporting their maximum intended load;

## 1910.23(d)(2)

The minimum perpendicular distance from the centerline of the steps or rungs, or grab bars, or both, to the nearest permanent object in back of the ladder is 7 inches (18 cm)

## 1910.23(d)(5)

For through ladders, the steps or rungs are omitted from the extensions, and the side rails are flared to provide not less than 24 inches (61 cm) and not more than 30 inches (76 cm) of clearance.

## 1910.23(d)(12)

The step-across distance from the centerline of the rungs or steps is:

## 1910.23(d)(12)(i)

For through ladders, not less than 7 inches (18 cm) and not more than 12 inches (30 cm) to the nearest edge of the structure, building, or equipment accessed from the ladders;





219 Safety Avenue / Andrews, SC 29510  
Ph: 888 878 1839 / Fx: 843 264 8584