



BARDE Bull Bar Installation Instructions

PART NO. IBCJT04

Fits: 2005 - Current Toyota Tacoma



60-120 min



Cutting May
Required



Drilling Not
Required

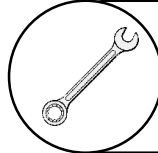

- **4mm ALLEN WRENCH (INCLUDED).**
- **13mm, 16mm & 18mm RATCHET WRENCH / RATCHET SOCKET (NOT INCLUDED).**

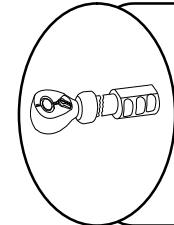

DO NOT OVER TORQUE. PLEASE FOLLOW THE TIGHTEN OPERATING LOAD STANDARD BELOW:

- 6mm BOLTS & NUTS: FROM 7 TO 8.5 FOOT POUND.**
- 8mm BOLTS & NUTS: FROM 18 TO 20 FOOT POUND.**
- 10mm BOLTS & NUTS: FROM 35 TO 40 FOOT POUND.**
- 12mm BOLTS & NUTS: FROM 60 TO 70 FOOT POUND.**



TO PROTECT YOUR INVESTMENT, DO NOT USE ANY TYPE OF POLISH OR WAX THAT MAY CONTAIN ABRASIVES THAT COULD DAMAGE THE FINISH. MILD SNOOP MAY BE USED TO CLEAN THE RUNNING BOARD.

REMOVE CONTENTS FROM BOX. VERIFY ALL PARTS ARE PRESENT DEPEND ON THE PARTS LIST. READ INSTRUCTIONS CAREFULLY BEFORE STARTING INSTALLATION. CUTTING MAY BE REQUIRED.



PARTS LIST:

No.	Description	Qty	Image
①	Bull Bar Body	1	
②	Mesh Panel	1	
③	Driver/Left Frame Bracket	1	
④	Passenger/Right Frame Bracket	1	
⑤	Driver/Left Mounting Bracket	1	
⑥	Passenger/Right Mounting Bracket	1	
⑦	Driver/Left L-Bracket	1	
⑧	Passenger/Right L-Bracket	1	
⑨	License Plate Bracket	1	
⑩	License Plate Plugs	2	
For Mounting the Brackets on the Frame			
⑪	10mm x 120mm Hex Bolts	2	
⑫	Spacer Washers	4	
⑬	10mm x 30mm OD x 2.5mm Flat Washers	4	
⑭	10mm Nylon Lock Nuts	2	
For Link the Mounting the Brackets and the Frame Bracket			
⑮	10mm x 30mm Hex Bolts	4	
⑬	10mm x 30mm OD x 2.5mm Flat Washers	8	
⑭	10mm Nylon Lock Nuts	4	
For Mounting the Brackets on the Bull Bar			
⑯	10mm x 25mm Hex Bolts	6	
⑰	10mm Lock Washers	6	
⑬	10mm x 30mm OD x 2.5mm Flat Washers	6	
For L Brackets and Mesh Panel Mount			
⑱	8mm x 20mm Hex Bolts	4	
⑲	8mm x 24mm OD x 2mm Flat Washers	8	
⑳	8mm Lock Washers	4	
㉑	8mm Hex Nuts	4	
For License Plate Bracket Mount			
㉒	6mm x 20mm Button Head Combo Bolts	2	
㉓	6mm Serrated Flange Nuts	2	
㉔	4mm Hex Wrench	1	

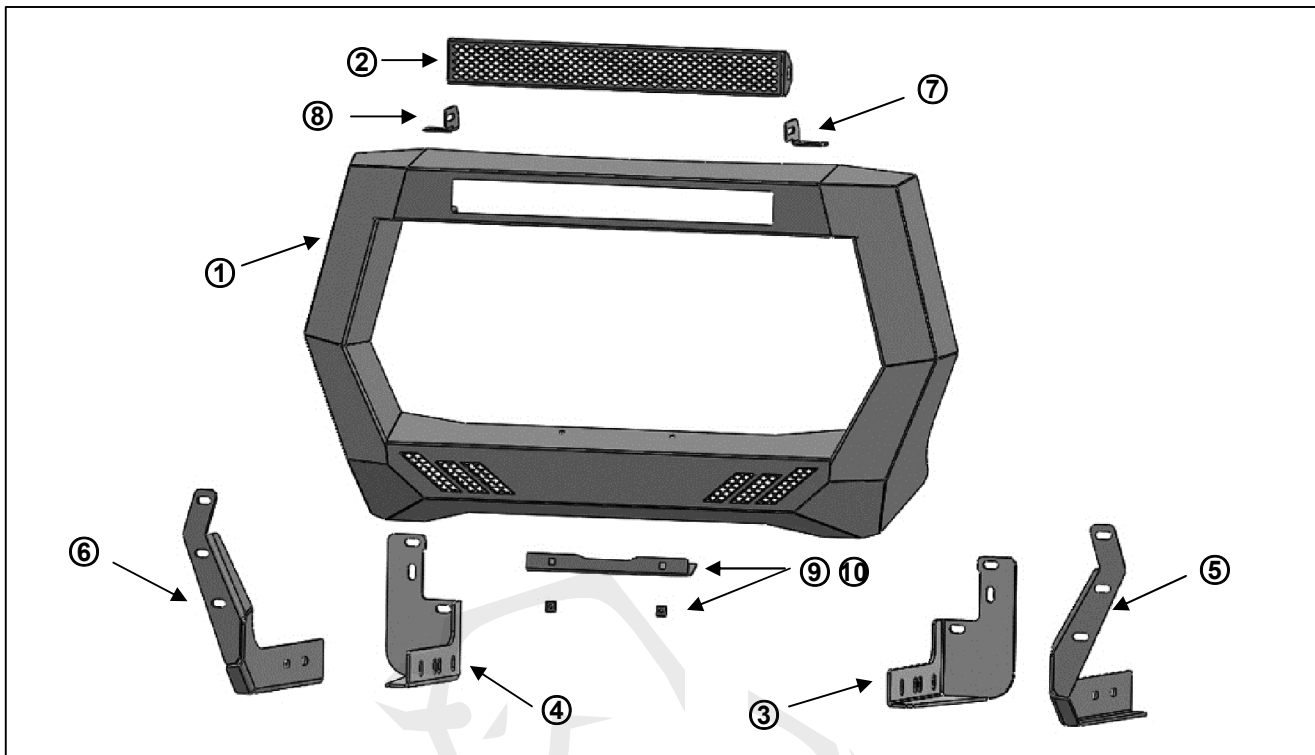

PROCEDURE:

1. Start installation at the passenger side, front of the vehicle. Remove the (2) outer factory hex nuts attaching the bumper mount to the end of the frame, **(Figure 1)**.
NOTE: It may be necessary to temporarily remove the factory tow hook from the passenger side.

Passenger/right Side Installation Pictured

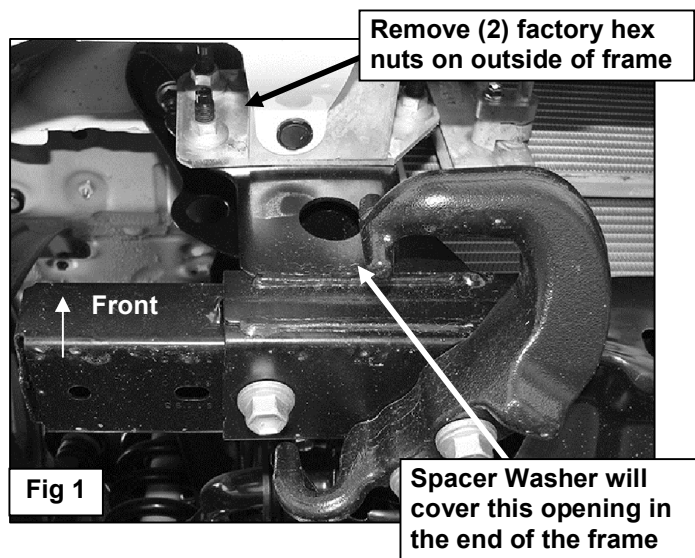
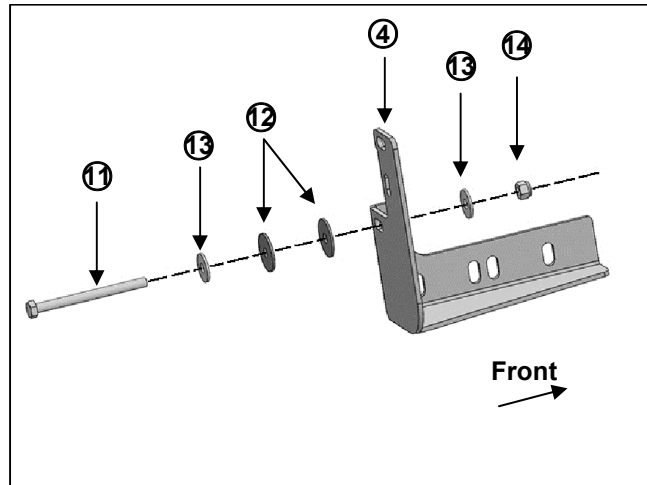

Fig 1

PROCEDURE:

2. Select the passenger side frame bracket ④. Slide the Bracket over the (2) threaded studs. Secure the Bracket to the studs with the factory hex nuts, (**Figure 2**). Leave hardware loose.

3. Insert (1) Spacer Washer ⑫ between the Frame Bracket and the frame cross member. Insert (1) 10mm x 120mm Hex Bolt ⑪ with (1) 10mm x 30mm Flat Washer ⑬ and (1) 10mm x 40mm Spacer Washer ⑫ into and through the hole in the back of the cross member, (**Figures 2 & 3**). Make sure the Spacer Washer is against the cross member covering the large hole, (**Figures 2 & 4**). Push the long bolt through the cross member, outer Spacer Washer and Frame Bracket. Secure the Bracket to the Bolt with (1) 10mm x 30mm Large Flat Washer ⑬, (1) 10mm Lock Nut ⑭, (**Figures 2—4**). Do not tighten hardware. Repeat this **Step** to attach the Driver/Left Frame Bracket ③ to the frame.

Passenger/right Side Installation Pictured

(Fig 2) Attach the Passenger/Right Frame Bracket to the end of the frame

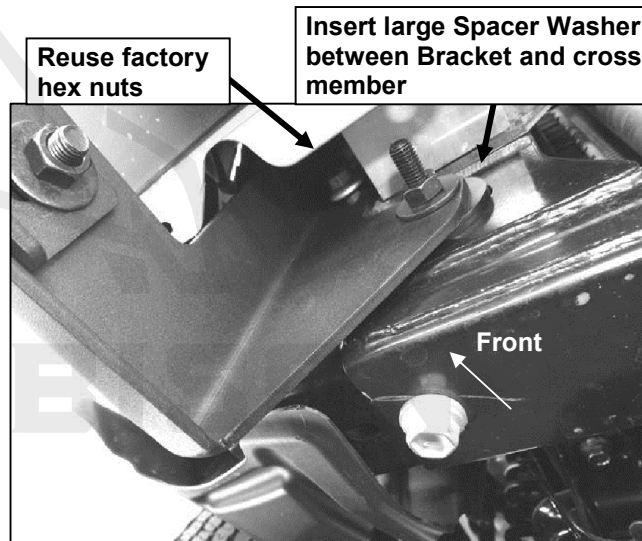

(Fig 3) Insert Spacer Washer between the Mounting Bracket and the frame before inserting long Hex Bolt through frame

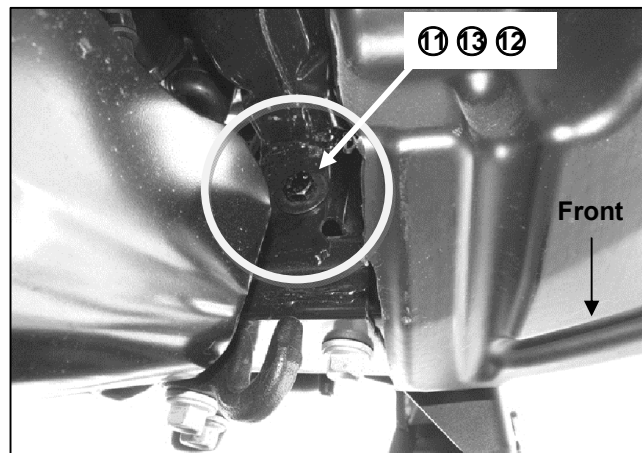

(Fig 4) Passenger side pictured from behind bumper

PROCEDURE:**4. For Mesh Panel attachment:**

- a. Select the Passenger/Right L-Bracket **⑧**.
- b. Attach the L-Bracket to the back of the Passenger/Right side of the Bull Bar with (1) 8mm Hex Bolt **⑱**, (2) 8mm Flat Washers **⑲**, (1) 8mm Lock Washer **⑳** and (1) 8mm Hex Nut **㉑**, (**Figure 5**).
- c. Repeat the previous **Step** to attach the Driver/Left L-Bracket **⑦** to the Bull Bar.
- d. Attach the Mesh Panel **②** to the (2) L-Brackets with (2) 8mm Hex Bolts **⑱**, (4) 8mm Flat Washers **⑲**, (2) 8mm Lock Washers **⑳** and (2) 8mm Hex Nuts **㉑**, (**Figure 5**).

5. Select the Passenger/Right Mounting Bracket **⑥**. Attach the Mounting Bracket to the back of the Bull Bar with (3) 10mm x 25mm Hex Bolts **⑯**, (3) 10mm Lock Washers **⑰** and (3) 10mm Flat Washers **⑬**, (**Figure 6**). Do not tighten hardware. Repeat this **Step** to attach the Driver/Left Mounting Bracket **⑤** to the Bull Bar.

6. Determine the year of the vehicle. Attach the Bull Bar to the (2) Frame Brackets with (4) 10mm x 30mm Hex Bolts **⑮**, (8) 10mm Flat Washers **⑬** and (4) 10mm Nylon Lock Nuts **⑭**, (**Figure 7**):
 - a. Model years **2005—2015**, use the back/in mounting position with Bull Bar Bracket pushed in to attach Brackets.
 - b. Model years **2016 - Current**, use the forward/out mounting position with Bull Bar Bracket pulled out to attach Brackets.

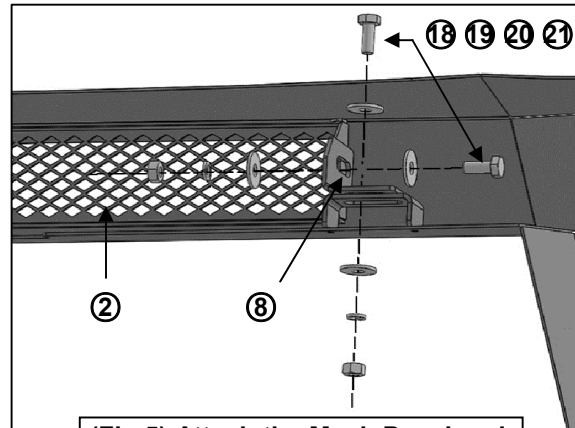
Passenger/right Side Installation Pictured

(Fig 5) Attach the Mesh Panel and the Passenger/Right L-Bracket to the back of the Bull Bar

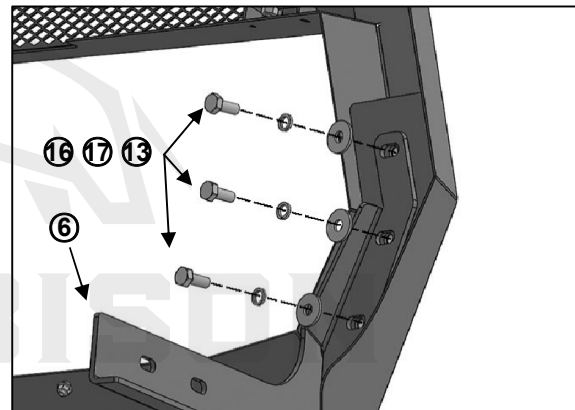

(Fig 6) Attach the Passenger/Right Mounting Bracket to the back of the Bull Bar

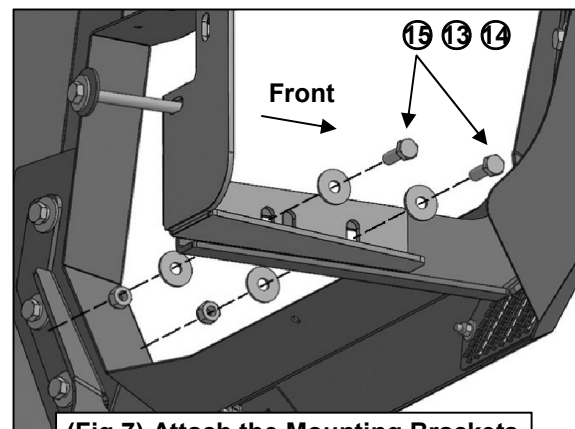

(Fig 7) Attach the Mounting Brackets to the Frame Brackets

PROCEDURE:

7. Relocation of front license plate may be necessary.
 - a. Attach the License Plate Bracket ⑨ to the front of the Bull Bar with (2) 6mm Button Head Combo Bolts ⑫ and (2) 6mm Serrated Flange Nuts ⑬, (Figure 8).
 - b. Insert the (2) License Plate Plugs ⑩ into the License Plate Bracket to attach the License Plate, if required, (Figure 9).
8. Level and adjust the Bull Bar properly and tighten all hardware.
9. Temporarily remove the Bull Bar and Mounting Brackets only. Hold the plastic air dam up in position against the Mounting Brackets. Trace the location of the two brackets onto the back of the air dam, (Figure 10). Use a sharp knife or hacksaw blade to carefully cut two slots to clear the brackets. **IMPORTANT:** Do not cut through the top or bottom edge of the air dam. Do not cut off the mounting tabs from the top of the air dam. For best results, check all measurements before cutting, start with a small opening and slowly enlarge the slots until Brackets clear the air dam. Reinstall the air dam but do not tighten hardware.
10. Reinstall the Bull Bar onto the Mounting Brackets.
11. Reinstall the tow hook if removed.
12. Do periodic inspections to the installation to make sure that all hardware is secure and tight.

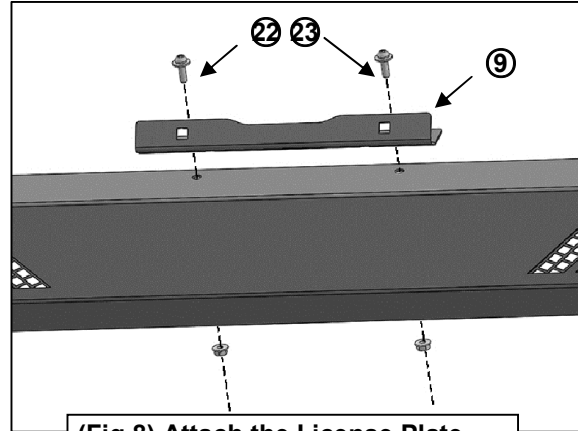
Passenger/right Side Installation Pictured

(Fig 8) Attach the License Plate Bracket to the front of the Bull Bar

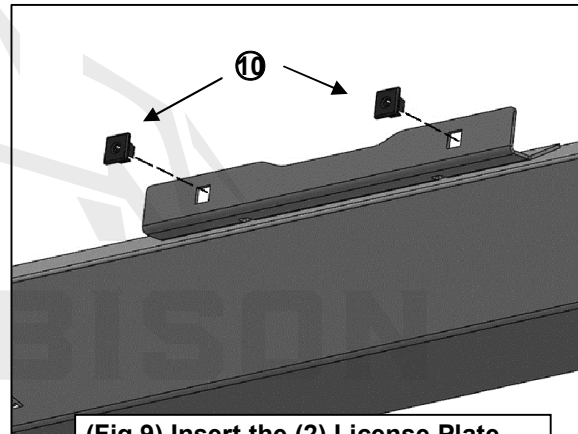

(Fig 9) Insert the (2) License Plate Plugs into the License Plate Bracket

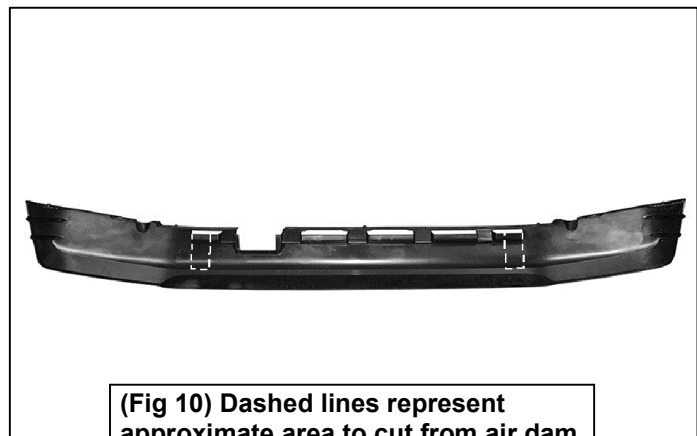

(Fig 10) Dashed lines represent approximate area to cut from air dam and are illustrated for example only