

The Little Green Jacket

By Jodi Dee

SEL PICTURE BOOK COMPANION



Giving
is the thread
that keeps us
together.

LITTLE GREEN JACKET

STORY CARDS



Based on true events.

The Little Green Jacket

By Jodi Dee

PREDICTING

What do you think the book 'The Little Green Jacket' is going to be about?

What can you do to help Earth? Explain your answer.

WRITING PROMPT:

20 differentiated & engaging activities!

RECYCLING: POSTER PROJECT

What are the names of the people in your group?

As a group, you will be creating a recycling poster. What message are you trying to spread?

Jodi Dee
©Jodi Dee, 2024

THE IMPORTANCE, POWER, AND MAGIC OF GIVING



© TheBrightCookie, 2024

THANK YOU! FOR YOUR SUPPORT!

Be the first to know when a new resource is posted or when I am having a sale on TPT. Click on my logo below to follow my TPT store.



If you enjoy this resource, please be sure to leave a REVIEW on TPT! By leaving a review, you earn TPT credits!

Let's Connect



Facebook



The Bright Cookie
Website



Instagram



Pinterest





Dear Customer,

I am the proud owner of the company / website
The Bright Cookie.

For additional FREE resources, products
(greeting cards coming soon), classroom activities
and materials, and my blog Please visit
[The Bright Cookie!](#)

Also, if you are interested in having custom
lesson plans or resources created for your
classroom, etc. [I create lesson plans/resources for hire!](#) Send an email for pricing!

Kristen
THE BRIGHT COOKIE

*Let's
Connect!*



The Bright
Cookie Website



Instagram



Pinterest



Facebook

Terms of Use

you may:

- Use free and purchased items for your classroom, students, or personal use.
- Reference this product in blog posts, seminars, professional development workshops, or other such venues. ONLY if both credits are given to The Bright Cooke and Jodi Dee Publishing AND links to
- The Bright Cookie [TPT store](#) and <https://jodidee.com/> are included in the presentation

you may not:

- Claim this work as your own, alter the files in any way, or remove copyright or watermarks.
- Sell the files or combine them into another unit for sale/free.
- Post this document for sale or for free anywhere (this includes online, Google Drive links in blogs, etc.).

Jodi Dee Publishing and The Bright Cookie are in collaboration for this FREE resource.

Jodi Dee's books are available at all major retailers and can be purchased wholesale for schools and educators from Baker and Taylor, Ingram, or directly at jodidee.com.

Thank you for abiding by universally accepted codes of professional ethics while using this product. If you encounter an issue with your file, notice an error, or are in any way experiencing a problem, please contact me and I will be more than happy to help sort it out. You can email The Bright Cookie a message at:

Kristen@thebrightcookie.com

The Little Green Jacket

By Jodi Dee

Co-Illustrated by Steve Good



Dear Educators,

Thank you for your interest and support of "The Little Green Jacket". I wrote this story to showcase the power and magic of giving. Hand-me-downs were a big part of my childhood, especially growing up with little means. Opening a garbage bag full of clothes from bigger cousins felt like Christmas morning.

I carried this into my children's lives even though they lived a much more privileged life. I have always donated used clothing and more. "One person's trash is truly another's treasure."

In the story you will see the jacket travel up and down different economic statuses. I wanted to break the paradigm that used goods only matter to the poor. Recycling is big part of our culture not only in protecting the environment but sharing abundance as a society. There are many layers to the story with hidden messages. It is a wonderful teaching resource.

What is your jacket's story?

With adoration & appreciation of all educators,

Jodi Dee

For more books & resources, visit jodidee.com
Connect with the author on social media @authorjodidee

3 Stories in 1!

This book can be read as 3 different stories! It can be read as the voices of the children (in white), The Little Green Jacket speaking (in green), or both combined.

For younger children under 6 years of age, reading each as a different story will more appropriately hold their attention. It will also be easier for them to digest and comprehend the content. There are many layers and points for discussion!

It's also a great teaching method to build different concepts and perspectives over time, eventually merging into one whole story.

Another great teaching technique is to use a puppet, to help children understand the voice of the Little Green Jacket, when it's 'talking'. It's also a fun activity to have children create their own little green jacket puppet.

For a free downloadable cutout puppet, coloring pages, and lesson plans, visit jodidee.com!



Seek & Find! 
Find the recycle symbols hidden in the images.

For more books and resources,
visit:

jodidee.com

Here are a few of her other inspiring books. Click on the cover to be directed to her site where you can read more details and purchase her books:

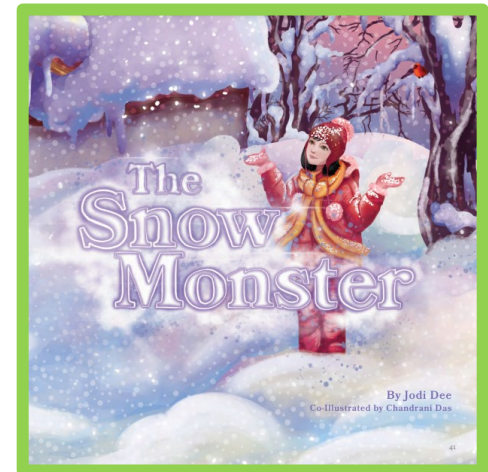
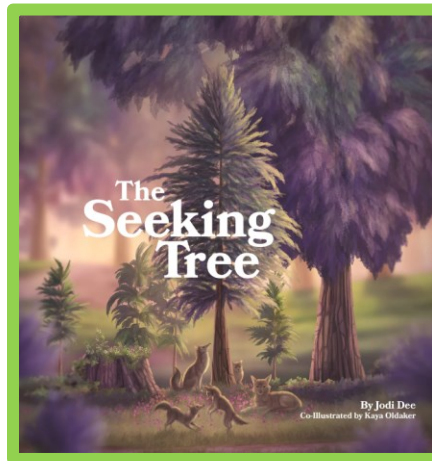

THE LITTLE GREEN JACKET

By Jodi Dee

_____ 's
Work Packet



SUMMARY



The Little Green Jacket is a story based on true events about a little green jacket that travels through the lives of different children, who live in very different places, and ends up on the other side of the world after a natural disaster.



DAY ONE:

THEME: THE IMPORTANCE, POWER, AND MAGIC OF GIVING

** Introduce the book's cover, and have the students predict what the story will be about. **

PREDICTING PAGE

You can have students share what they predict the book is about based on just seeing the cover. This can be a whole-group activity, or you can have the students share with a shoulder partner or their small group. (It is available in printable or digital versions.)

Ask the students: What do you base your predictions on?

READ ALOUD #1

STORY CONCEPTS PAGE-

After reading the story for the first time, students will complete the story concepts page. (It is available in printable or digital form.)

RURAL, URBAN, and SUBURBAN This slide gives the teacher a visual example and explanation to show students the difference between rural, urban, and suburban communities. This will help them on the following Compare and Contrast activity.

COMPARE AND CONTRAST WHERE THE CHARACTERS LIVE: Independently, in partners, or in small groups, students will compare where the four main characters live by providing evidence from the text. Answer key provided. (It is available in printable or digital form.)

DESIGN YOUR OWN Jacket:

Students can design what they would want their "lucky jacket" to look like. Once again, they can use their creativity to complete this activity.



THE LITTLE GREEN JACKET By Jodi Dee

PREDICTING

What do you think the book The Little Green Jacket is going to be about?





THE LITTLE GREEN JACKET By Jodi Dee

PREDICTING

What do you think the book The Little Green Jacket is going to be about?

Eight horizontal lines provided for writing a prediction about the book.





THE LITTLE GREEN JACKET By Jodi Dee

PREDICTING

What do you think the book The Little Green Jacket is going to be about?



Jodi Dee ©
©Jodi Dee, 2024

©TheBrightCookie, 2024





THE LITTLE GREEN JACKET

By Jodi Dee

PREDICTING

What do you think the book The Little Green Jacket is going to be about?



THE LITTLE GREEN JACKET STORY CONCEPTS



CHARACTERS:



SETTINGS: (There was more than one)

PROBLEM:



SOLUTION:

FAVORITE PART:



THE LITTLE GREEN JACKET

RURAL-

Rural locations are "out in the country," and are not densely populated. They are outside of cities, further away than suburbs. In rural settings, there are typically large areas of undeveloped land.



URBAN-

The word urban is used to refer to cities. A lot of people live and work within cities. Cities are densely populated, and a fast-paced lifestyle tends to be the norm.



SUBURBAN-

Suburban areas are locations that build up around the outside of cities. They tend to be less densely populated than the cities they surround. Most homes in the suburbs are located in subdivisions zoned exclusively for residential purposes. They typically have more land than homes in urban neighborhoods and less than homes in rural areas.



COMPARE AND CONTRAST

List details about where Mike, Diego, Vanessa and Austin live. How are they alike and different?

Use text evidence to complete the boxes.

Where Mike Lives:



Where Diego Lives:



Where Vanessa and Austin Live:



ANSWER KEY

COMPARE AND CONTRAST

List details about where Mike, Diego, Vanessa and Austin live. How are they alike and different?

Provide text evidence.

Where Mike Lives:



- **Rural**
- Vast land
- Cows, chickens, and other animals to take care of
- Enough land to sled on.
- Fields that glistened and sparkled.
- Has tractors- (Mike's won first place at the fair.)
- Mike plays in a field

Where Diego Lives:



- **Urban**
- Diego's room is up high in the sky.
- So many buildings and windows.
- Diego and his friends hangout on the sidewalk and stairs.
- It is busy all day and all night.
- Noises come close and far.
- Diego can walk to many places he needs to go.

Where Vanessa and Austin Live:



- **Suburban**
- There are backgrounds to play in.
- Vanessa and Austin live in two houses. One with their dad, and one with their mom.
- There are other houses on their street, not too close or far apart.

DESIGN YOUR OWN "LUCKY JACKET."

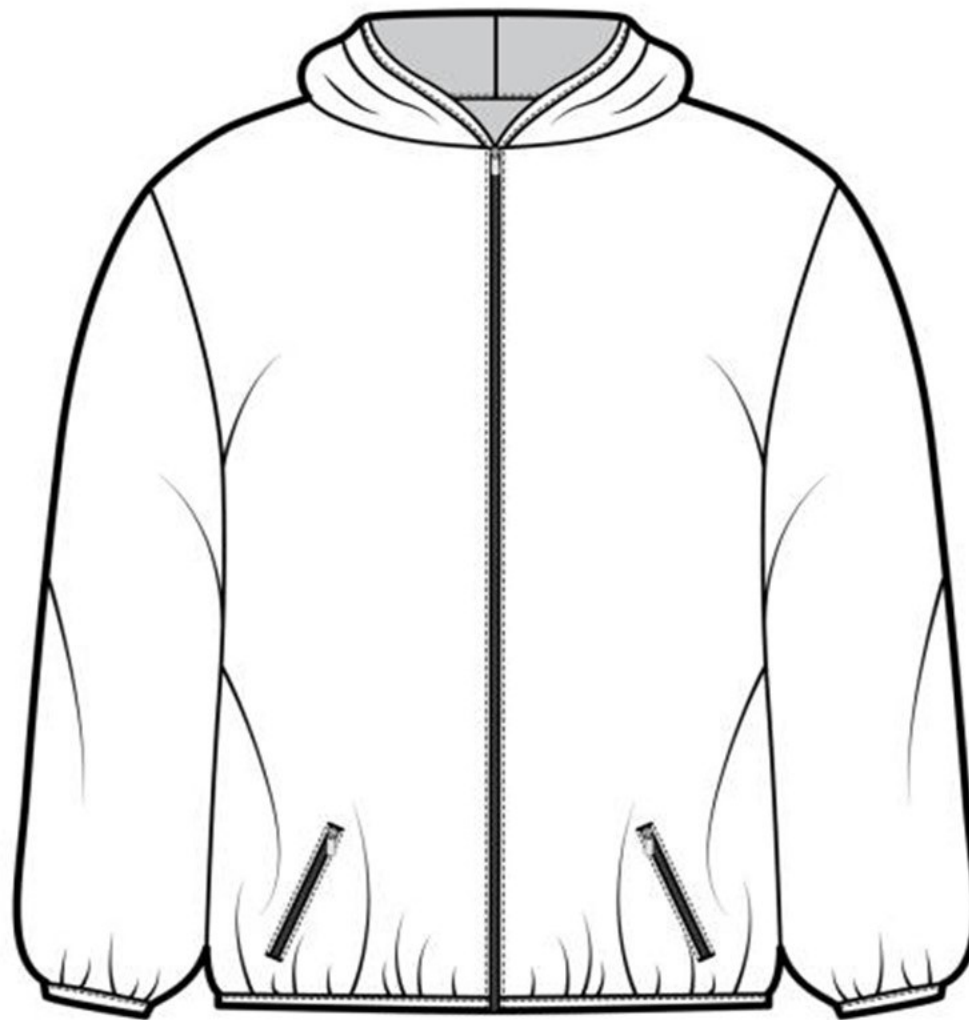

DESIGN YOUR OWN "LUCKY JACKET."



DAY TWO:

THEME: THE IMPORTANCE, POWER, AND MAGIC OF GIVING

Jodi Dee
©Jodi Dee, 2024

READ ALOUD #2-

Today, we will focus on the text's theme (or message), sequencing of events in the story, a writing prompt, and an optional coloring page.

THEME or MESSAGE:

Students will predict what they think is the central theme (or message) in [The Little Green Jacket](#) by explaining their thinking.

(For younger students) The teacher can have the class brainstorm different ideas for the central theme with the class, and then students can choose which one they believe to be true.

SEQUENCING OF EVENTS IN THE STORY:

Students will cut out the picture cards and paste them in order they happened on the "Sequence of Events" page. An answer key is provided. *If planning on using this as a center, the teacher can run it on paper OR laminate for future use.

WRITING PROMPT Have you ever been teased by someone? How did it make you feel?- black & white, colored, different line templates, and digital version available.

COLORING PAGE: "Love is Universal"

©TheBrightCookie, 2024

THE LITTLE GREEN JACKET By Jodi Dee



THEME / MESSAGE

What is the central theme (or message) in The Little Green Jacket?

Draw a picture to go with what you wrote about:

Jodi Dee

©Jodi Dee, 2024

©TheBrightCookie, 2024

THE LITTLE GREEN JACKET

By Jodi Dee



THEME / MESSAGE

What is the central theme (or message) in The Little Green Jacket?

Handwriting practice area with 10 sets of lines. Each set consists of a solid top line, a dashed middle line, and a solid bottom line.

Draw a picture to go with what you wrote about:

Large empty rectangular box for drawing a picture.

©Zip-A Dee-Doo-Dah Designs | All Rights Reserved.

THE LITTLE GREEN JACKET

By Jodi Dee



THEME / MESSAGE

What is the central theme (or message) in The Little Green Jacket?
Explain your thinking.

Draw a picture to go with what you wrote about:

A large, empty rectangular box with a scalloped border, intended for a drawing related to the theme or message.

THE LITTLE GREEN JACKET

Jodi Dee ©
©Jodi Dee, 2021

STORY CARDS



SEQUENCE OF EVENTS

Jodi Deez
©Jodi Deez, 2021

Cut out the picture cards and glue them in the order they happened in the story.

1

2

3

4

5

6

7

8

9

SEQUENCING OF EVENTS

ANSWER KEY

1.



2.



3.



4.



5.



6.



7.



8.



9.



In the book, classmates teased Mike by saying, "Hey Mikey! Isn't that the same jacket you wore last year?"

HAVE YOU EVER BEEN TEASED BY SOMEONE? HOW DID IT MAKE YOU FEEL?



In the book, classmates teased Mike by saying, "Hey Mikey! Isn't that the same jacket you wore last year?"

HAVE YOU EVER BEEN TEASED BY SOMEONE? HOW DID IT MAKE YOU FEEL?



In the book, classmates teased Mike by saying, "Hey Mikey! Isn't that the same jacket you wore last year?"

HAVE YOU EVER BEEN TEASED BY SOMEONE? HOW DID IT MAKE YOU FEEL?



“LOVE



is



UNIVERSAL.”

~ THE LITTLE GREEN JACKET

DAY THREE:

THEME: THE IMPORTANCE, POWER, AND MAGIC OF GIVING

READ ALOUD #3 (or silent read at a station)-

Today, we will focus on summarizing, completing question stem cards with partners or groups, and a quote analysis page to discuss and complete.

SUMMARIZING:

Students will write 1-2 complete sentences from the beginning, middle, and end of the story to make a quick summary of the overall book. This page can be given to them in a hardcopy packet or assigned to them on a digital platform.

QUESTION STEM TASK CARDS #1-4

Students will work in partners or small groups to discuss and then record their answers to the questions. Printable black and white, colored, AND digital versions available. Answer key included.

QUOTE ANALYSIS PAGE:

Students will read the quote and write what they think it's meaning is in their own words. This would be a great activity to have them share out loud with the class or their group.



THE LITTLE GREEN JACKET

By Jodi Dee

SUMMARIZING

Write a couple of sentences from the beginning, the middle, and the end of the story. Put them altogether and you have the summary of the story.

Beginning:

Middle:

End:



THE LITTLE GREEN JACKET

By Jodi Dee

Question Task Cards #1-4

For independent work, partners, or small groups.



1.

What do Mike, Diego, Vanessa, and Austin all do when they receive the green jacket?

2.

What do each of the main characters call the jacket?

3.

Pg 35- Austin says, "If those poor families lost everything, I know my jacket will make someone just as happy as me."

Describe what type of character traits Austin seems to have?

4.

Do you think donating something you love is a good choice or bad choice?

THE LITTLE GREEN JACKET

By Jodi Dee

ANSWER KEY

Question Stems #1-4

1. What do Mike, Diego, Vanessa, and Austin ALL do when they receive the green jacket?

Hold it up high and smile

2. What do each of the main characters call the jacket?

"My lucky jacket."

3. Describe what type of character traits Austin seems to have?

Kind-hearted, giving, generous, selfless
Answers will vary.

4. Do you think donating something you love is a good choice or bad choice?

Answers will vary.

THE LITTLE GREEN JACKET

By Jodi Dee

Question Stem Recording Sheet:
Task Cards #1-4

1.

2.

3.

4.



THE LITTLE GREEN JACKET By Jodi Dee

QUOTE ANALYSIS



In your own words, write what you think the following quote means:

“One person’s trash can be another person’s treasure.”



THE LITTLE GREEN JACKET By Jodi Dee

QUOTE ANALYSIS



In your own words, write what you think the following quote means:

“One person’s trash can be another person’s treasure.”

DAY FOUR:

At this point, it is up to the teacher to read the book aloud once again or have students complete work based on the three previous times the book has been read to them. Today, we will focus on vocabulary, and beginning a Recycling Poster Project.

*VOCABULARY FIND / CONTEXT CLUES:

Students are to look up each vocabulary word (page number is provided) and write the sentence the word is found in. For the Context Clue page, students will use the context clues from the sentence to define the vocabulary word in their own words.

*****Before introducing the recycling information assignment. Make sure that you go over and brainstorm ideas on the board of WHAT recycling really is:

The word 'recycle' has two meaningful parts – 're' and 'cycle'. 'Re' means 'again'. 'Cycle' means something that goes around, like a bicycle that has round tires. Cycle can also mean that things happen over and over again.... In this story, something will be 'recycled' by being shared with others many times.

*RECYCLING INFORMATION PAGE

*START RECYCLING POSTER GROUP PROJECT- Teacher page, recording sheet, and two pages of facts are provided for this activity.

Fun Facts provided by: <https://recyclingpartnership.org/communitiesforrecycling/16-fun-recycling-facts-for-kids/>



THE LITTLE GREEN JACKET

By Jodi Dee

VOCABULARY FIND

Find the following vocabulary words in sentences in the text. Write the sentence in the blank. Circle the vocabulary word within the sentence.

Page 4:
gleefully

Page 5:
mused

Page 6:
glisten

Page 10:
sulked

Page 20:
declared

Page 27:
snickered



CONTEXT CLUES

Write what you think the vocabulary word means based on the sentence that it is in and the context clues around it.

Page 4:
gleefully

Page 5:
mused

Page 6:
glisten

Page 10:
sulked

Page 20:
declared

Page 27:
snickered



THE LITTLE GREEN JACKET

By Jodi Dee

RECYCLING

What does the word recycling mean?

Where are some places that you have seen the recycling sign before?



What are some items you and your family can recycle?



RECYCLING: POSTER PROJECT- TEACHER PAGE

MATERIALS NEEDED: Poster board (or butcher paper) and coloring utensils for each group.

This group Recycling Poster Project is a hands-on way to teach and implement the importance of recycling and giving to a cause.

The ten “fun facts” that are provided on two pages are for the teacher to read or present on the board to the class. (Some are amazing!)

Next, the teacher will divide the students into small groups and give each group a copy of the facts and the recording sheet.

Each group will pick 2-3 facts (or teacher choice) to display on their recycling poster.

Each poster should convey the message that recycling is a great thing we all can do that benefits the Earth and the people around us. The same is true of donating. As the book discusses, it benefits others besides themselves. (This is a critical lesson within itself.)

“Giving is the thread that keeps us together.”

Encourage the groups to be neat and creative. You could even turn it into a contest!





RECYCLING FUN FACTS: DID YOU KNOW?

PAGE 1

1. The average person creates almost five pounds of trash per day, and in 2018, American consumers created 146.2 million tons of trash that ended up in landfills. Thankfully, Americans also recycled and composted almost 94 million tons of waste.
2. Cardboard (also known as corrugated) boxes can be recycled at least seven times and can be used to make new packaging boxes and even furniture. The best part is, recycling cardboard is easy. Almost all Americans having access to curbside recycling for their corrugated boxes. Just make sure they're empty, dry, clean, and flattened.
3. How long does it take for a used aluminum drink can to be recycled into a new one and put back on the grocery shelf? Just 60 days.
4. Every year, 2.4 million tons of recycled glass are used to make new bottles and jars. Recycling glass is great because it can be recycled endlessly with no loss in quality or purity.
5. Did you know: Whether you're recycling a plastic drink bottle, shampoo container, peanut butter jar, or laundry detergent bottle, you can keep the cap on when you put it in your recycle bin in most community programs? Make sure the plastic containers are empty and dry. When they are processed for recycling, the bottles and caps are ground into plastic flakes that are vigorously washed and separated in a tank where different materials float and sink.





RECYCLING FUN FACTS: DID YOU KNOW?

6. More than 52 million tons of paper products were recycled in 2018. That's roughly the same weight as almost 350,000 blue whales.
7. Recycling helps save energy. If you recycle one glass bottle, it saves enough energy to light a 100-watt bulb for four hours, power a computer for 30 minutes, or a television for 20 minutes.
8. Recycling one aluminum can saves enough energy to run a 55-inch HDTV to watch your favorite movie. If we recycled all the aluminum cans in the U.S., the energy saved could power 4.1 million homes for a full year.
9. What happens to recycled plastic containers? They can be used to make new plastic containers, but it doesn't stop there. Recycled plastic can also be used in creating other things like cell phone cases, playground equipment, clothes, and rugs.
10. Does your favorite morning drink come in a carton? Well, that carton is a valuable recyclable material! The paper pulp and press board that comes from recycled cartons can be used to make toilet paper, paper towels, or even eco-friendly building materials like roof cover boards.



RECYCLING: POSTER PROJECT

RECORDING SHEET

What are the names of the people in your group:

As a group, decide the 2-3 facts that you want to include on your poster. Write the number of the facts below:
(For example, if you are going to use Fact #1 and #8, then write those numbers below)

What would be the point of making a recycling poster? What message are you trying to spread?

Is donating considered recycling? Why or why not?
(Think about what this book is about.)

What pictures or drawings will you include on your poster to get the message across and be creative?



DAY FIVE:

THEME: THE IMPORTANCE, POWER, AND MAGIC OF GIVING

Jodi Dee
Publishing
©Jodi Dee, 2024

WRITING PROMPT #2:

What can you do to save the Earth? – 4 templates
An illustration page is provided as well.

FINISH RECYCLING POSTER PROJECT- When student groups complete their posters, they will take turns presenting them to the class.

ART PROJECTS FOR KIDS: "How to Draw a Jacket" lesson

This lesson is provided to you by <https://artprojectsforkids.org/> where you can find FREE "How-to-Draw" lessons of your choice!

*(Permission given by Kathy Barbro at kathy@artprojectsforkids.org)

COLORING PAGES:

A coloring page is provided for students to color during independent work or stations. The teacher can take this time to review any concepts covered during this SEL picture book unit.

These pages can be completed throughout the week.

WRITING PROMPT:

Jodi Dee
Publishing
©Jodi Dee, 2024

What can you do to help Earth? Explain your answer.



WRITING PROMPT:

Jodi Dee
Publishing
©Jodi Dee, 2024

What can you do to help Earth? Explain your answer.

Handwriting practice area with four sets of lines: a solid top line, a dashed middle line, and a solid bottom line.



©Zip-A-Dee-Do-It Publishing, All Rights Reserved.

ILLUSTRATE YOUR WRITING:

Jodi Dee
Publishing
©Jodi Dee, 2024

©TheBrightCookie, 2024

How to Draw a Jacket - (Color yours green instead of red to match the jacket in the book.)

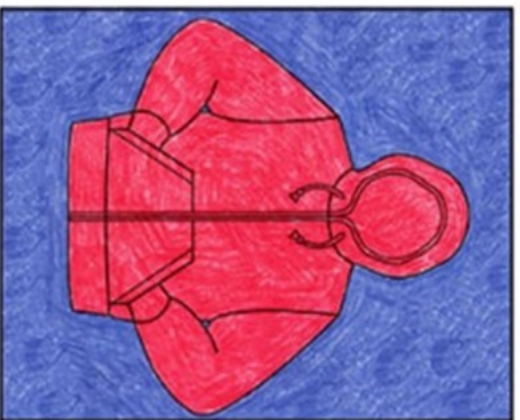
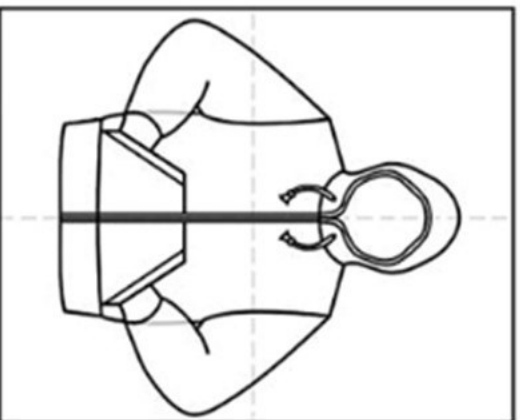
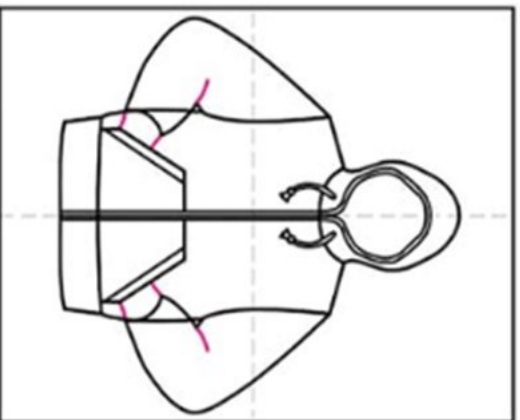
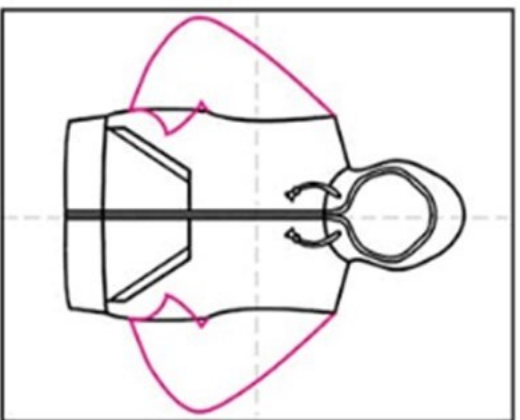
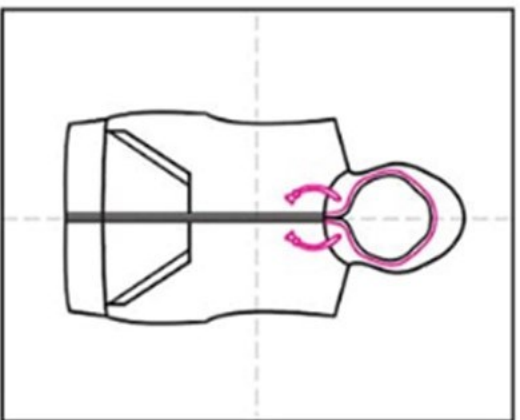
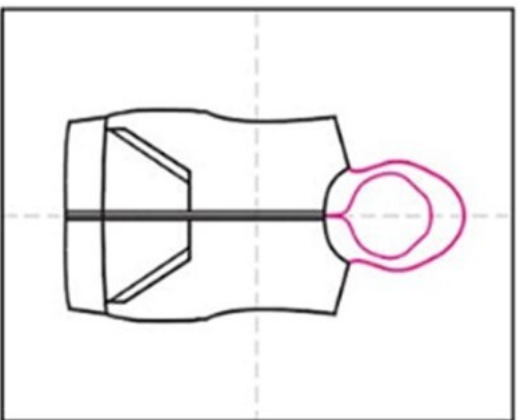
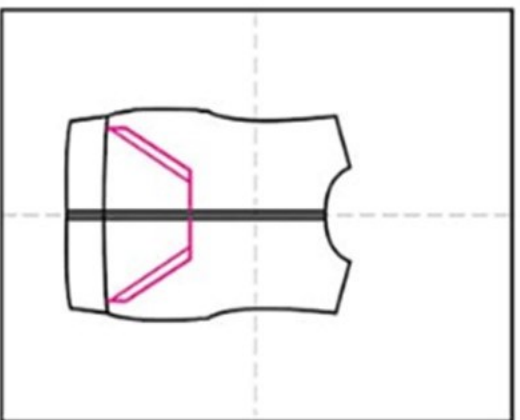
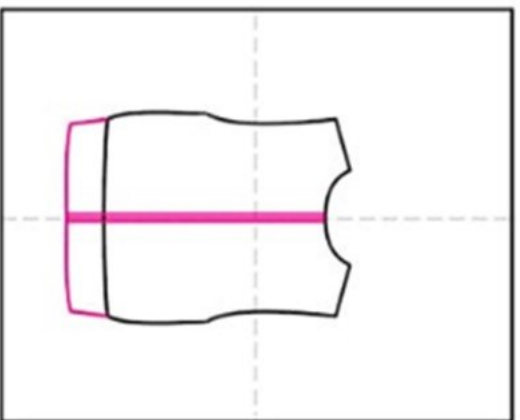
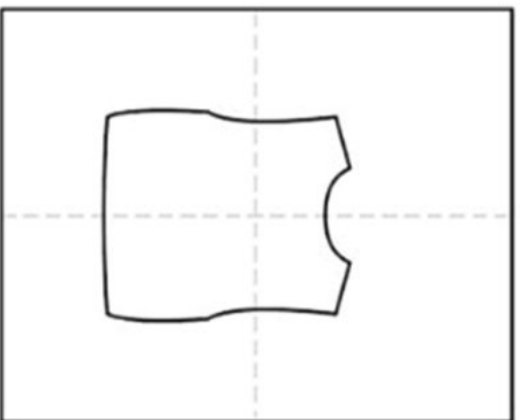

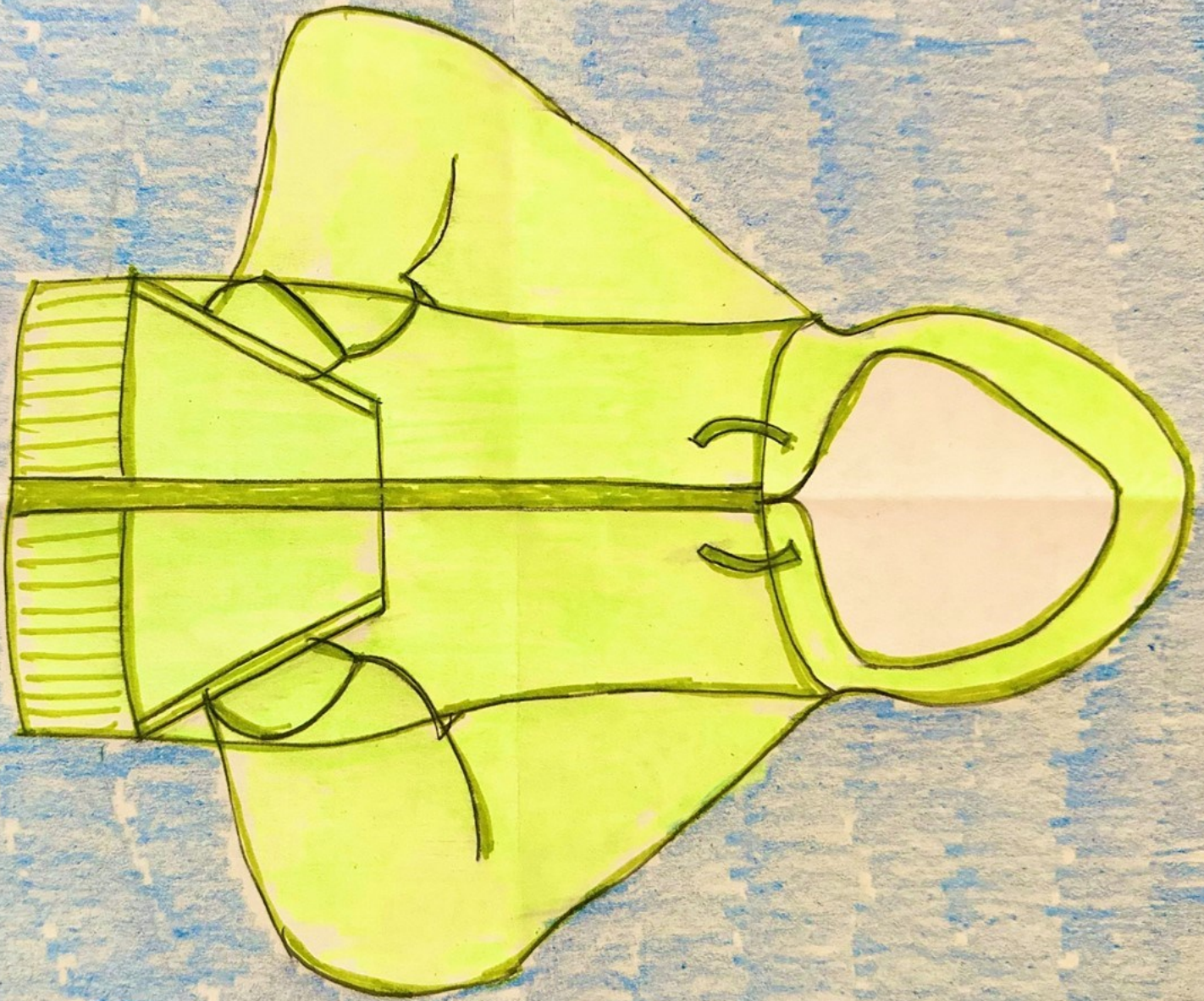



“

Giving



is the thread

that keeps us

TOGETHER.”

~THE LITTLE GREEN JACKET



The Little Green Jacket

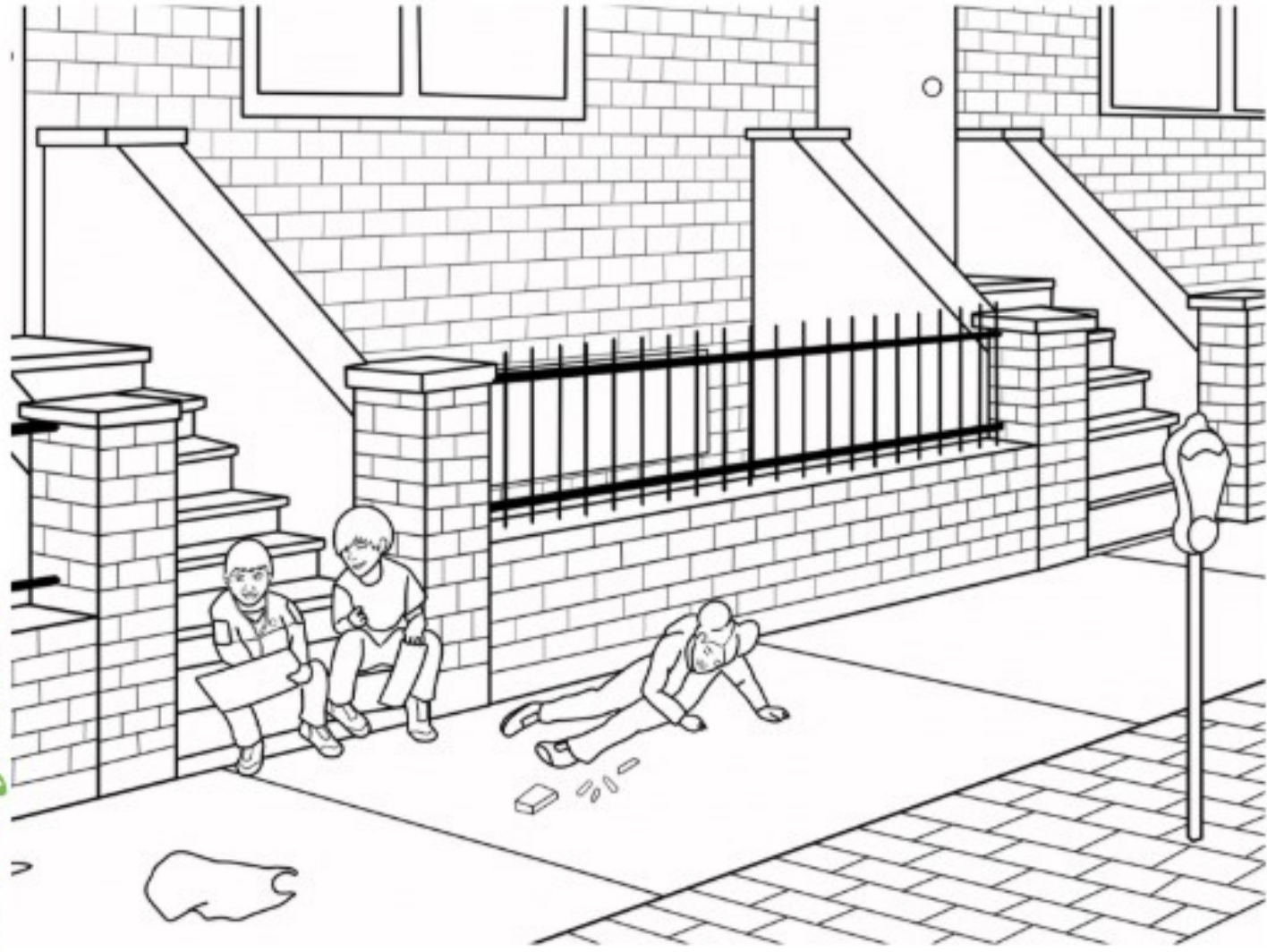

Story by Jodi Dee
Co-illustrated by Steve Goad

© Jodi Dee™

TO ACCESS YOUR
DIGITAL RESOURCE,
READ THIS PAGE.



GOOGLE SLIDES LINK:

For the DIGITAL section of your resource.

WHAT YOU NEED TO GET STARTED:

1. Download Link for the Google Slide Product and make a copy.
2. Have access to the Internet and a Google Account. (FREE)
3. Open the file on your own Google Drive and engage while in the edit mode.

THIS IS YOUR MASTER TEMPLATE!

1. CLICK THE **STAR** below to make your master copy on Google.
2. Once you make your master copy and rename it to the title of your choice, you can assign it to your students in Google Classroom, on their Google Drives, or in Canva.

*There are multiple platforms that you can use this digital file with.

**To show and/or explain to your students how to complete the assignment, download it as a PowerPoint from your Google doc.

If you notice an issue with your file,
notice an error,
or in any way encounter an error,
please contact me at

kristen@thebrightcookie.com

and I will be more than happy to
sort it out!



Credits

Thank you to all the incredible artists for their beautiful design elements and expertise contributed towards this resource!

Jodi Dee

Publishing

<https://artprojectsforkids.org/>

