



DOOR PREPARATION INSTRUCTION FOR PUSH PULL ROTATE HANDLESETS

FOR PUSH PULL ROTATE ENTRY DOOR HANDLESETS.

QUESTIONS? CALL 1-800-562-5625 FOR HELP.

999-00339E_EN

MARKING THE HOLE LOCATIONS

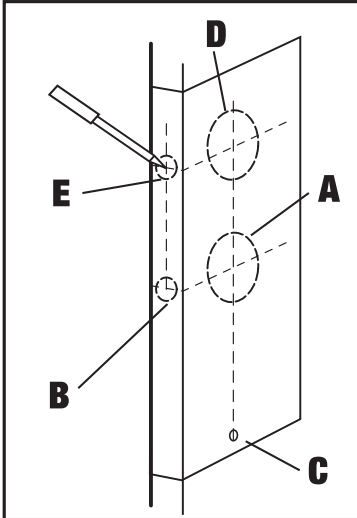

Converting from an existing standard door knob to a handleset.

- Remove existing hardware.
- Determine the side of the template that allows you to place it on the **OUTSIDE** surface of the door. Fold enclosed template along indicated line and place template against door edge.
- Align Hole A on template with existing door knob hole.
- Mark Hole C, but do not drill until confirming location. **Ensure Hole C is directly below the center of Hole A.**
- Confirm all other holes are properly prepared and proceed to the hardware installation instructions.

FOR NEW INSTALLATION INTO A NON-BORED DOOR

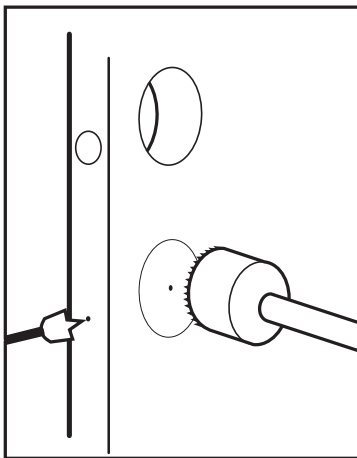

- Determine the side of the template that allows you to place it on the **OUTSIDE** surface of the door. Fold enclosed template along indicated line and position template against door edge at desired height. (Handleset is typically 38" (965 mm) from the ground with deadbolt located at least 5-1/2" (140 mm) above handleset).
- Determine door thickness and desired backset and mark centers for Holes A through E.
- Drill designated diameters for holes A, B, D, and E. Mark Hole C, but do not drill until confirming the location. **Ensure Hole C is directly below the center of Hole A.**

LATCH RECESS PREPARATION

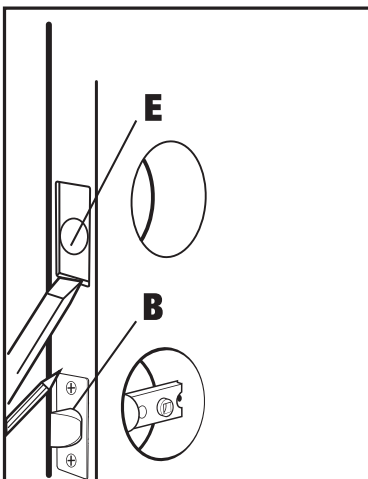

- Insert Deadbolt latch into Hole E and Handleset latch into Hole B.
- Outline each latch faceplate onto door edge.
- Remove latches and chisel outlined area approximately 5/32" (4 mm) deep or until each faceplate is flush.
- Reinsert latches into the respective holes, mark and drill pilot holes for faceplate screws.

STRIKE PLATE PREPARATION

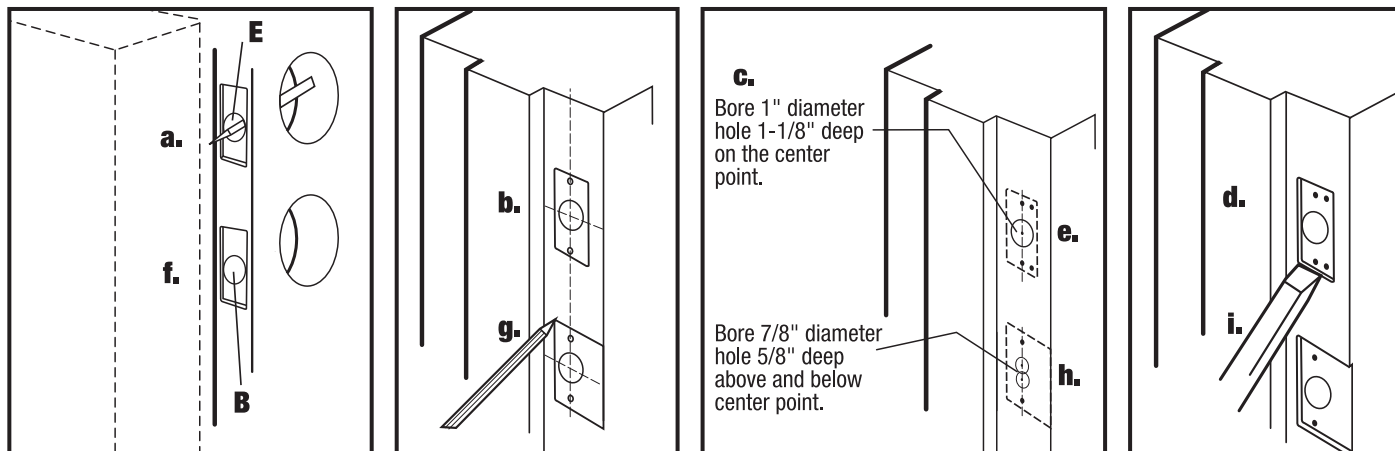

FOR DEADBOLT STRIKE PLATE (SEE 999-00340E_EN STEP 12 FOR INSTALLATION INSTRUCTIONS)

- a) With door closed, use a nail or marker through Hole E to mark center location of strike plate onto door jamb.
- b) Using the strike plate as a template, outline plate onto door jamb.
- c) Drill a 1" (25.4 mm) hole 1-1/8" (28 mm) deep on the center location mark.
- d) Chisel out outlined area approximately 7/32" (5.5 mm) deep or until strike plate and strike subplate are flush.
- e) Reposition strike plate and strike subplate. Mark and drill 4 pilot holes for screws.

FOR HANDLESET STRIKE PLATE (SEE 999-00340E_EN STEP 12 FOR INSTALLATION INSTRUCTIONS)

- f) With door closed, use a nail or marker through Hole B to mark center location of strike plate onto door jamb.
- g) Using the curved strike plate as a template, outline plate onto door jamb.
- h) Drill two 7/8" (22 mm) holes 5/8" (16 mm) deep above and below center location mark, barely overlapping each other. Chisel out remaining edge material.
- i) Chisel out outlined area approximately 1/16" (1.6 mm) deep or until strike plate is flush.
- j) Reposition strike plate, mark and drill pilot holes for screws.

CONFIRM THAT ALL HOLES HAVE BEEN PROPERLY PREPARED AND PROCEED TO THE HARDWARE INSTALLATION INSTRUCTIONS.

LIMITED LIFETIME WARRANTY- This product is warranted by Hampton Products International ("HPI") with a limited lifetime mechanical and finish warranty to the original consumer user of this product against defects in material and workmanship under normal use and service as long as the original consumer user occupies the residential premises upon which this product was originally installed. This warranty does not apply to product: used in commercial or common area applications; used for purposes for which it was not designed or intended; and which has been abused, misused, modified, or improperly installed, operated, maintained, and/or repaired. This warranty does not cover scratches, abrasions, or deterioration due to the use of paints, solvents, or other chemicals. **HPI IS NOT LIABLE FOR INCIDENTAL, INDIRECT, OR CONSEQUENTIAL DAMAGES.** Some states do not allow the exclusion or limitation of incidental or consequential damages, so the above exclusion may not apply to you. This warranty provides you with specific legal rights and you may also have other rights that vary from state to state. To make a warranty claim, please contact Hampton Care at 1-800-562-5625 or visit our website at www.hampton.care for instructions on how to have the product replaced, exchanged for a similar product of equal value, or repaired.



BRINKS A TRUSTED NAME IN SECURITY SINCE 1859 and all related logos are trademarks or registered trademarks of Brink's Network, Inc, and are used with permission.

999-00339E_EN



50 Icon, Foothill Ranch, CA 92610-3000
1-800-562-5625 • www.hamptonproducts.com
©2018 Hampton Products International Corp.
www.brinksprr.com
999-00339E_EN_REV05/18