

NOTE: IF YOUR MODEL IS PROVIDED WITH A DEADBOLT, USE THE SEPARATE INSTRUCTIONS FOR THAT ITEM FOR DOOR PREPARATION AND PRODUCT INSTALLATION.

QUESTIONS? CALL 1-800-562-5625 FOR HELP.

MARKING THE HOLE LOCATIONS

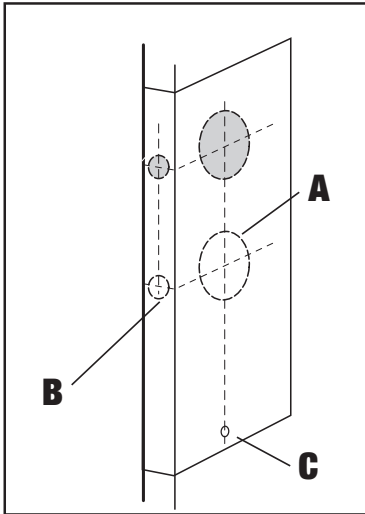

Converting from an existing standard door knob to a handleset.

- Remove existing hardware.
- Determine the side of the template that allows you to place it on the **OUTSIDE** surface of the door. Fold enclosed template along indicated line and place template against door edge.
- Align Hole A on template with existing door knob hole.
- Mark Hole C using the template provided, but do not drill until confirming location. **Ensure Hole C is directly below the center of Hole A.**
- Confirm all other holes are properly prepared and proceed to the hardware installation instructions.

FOR NEW INSTALLATION INTO A NON-BORED DOOR

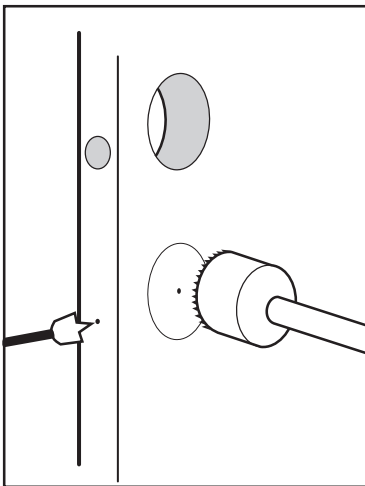

- Determine the side of the template that allows you to place it on the **OUTSIDE** surface of the door. Fold enclosed template along indicated line and position template against door edge at desired height. (Handleset is typically 38" [965 mm] from the ground with deadbolt located at least 5-1/2" [140 mm] above handleset).
- Determine door thickness and desired backset and mark centers for Holes A, B, and C.
- Drill designated diameters for holes A and B. Mark Hole C, but do not drill until confirming the location. **Ensure Hole C is directly below the center of Hole A.**

LATCH RECESS PREPARATION

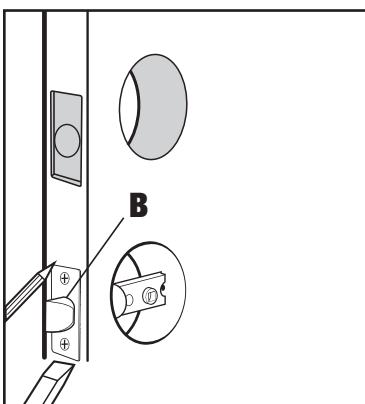

- Insert Handleset latch (A) into Hole B.
- Outline latch faceplate onto door edge.
- Remove latch and chisel outlined area approximately 5/32" (4 mm) deep or until faceplate is flush.
- Re-insert latch into Hole B, mark and drill pilot holes for faceplate screws.

QUESTIONS? CALL 1-800-562-5625 FOR HELP.

STRIKE PLATE PREPARATION

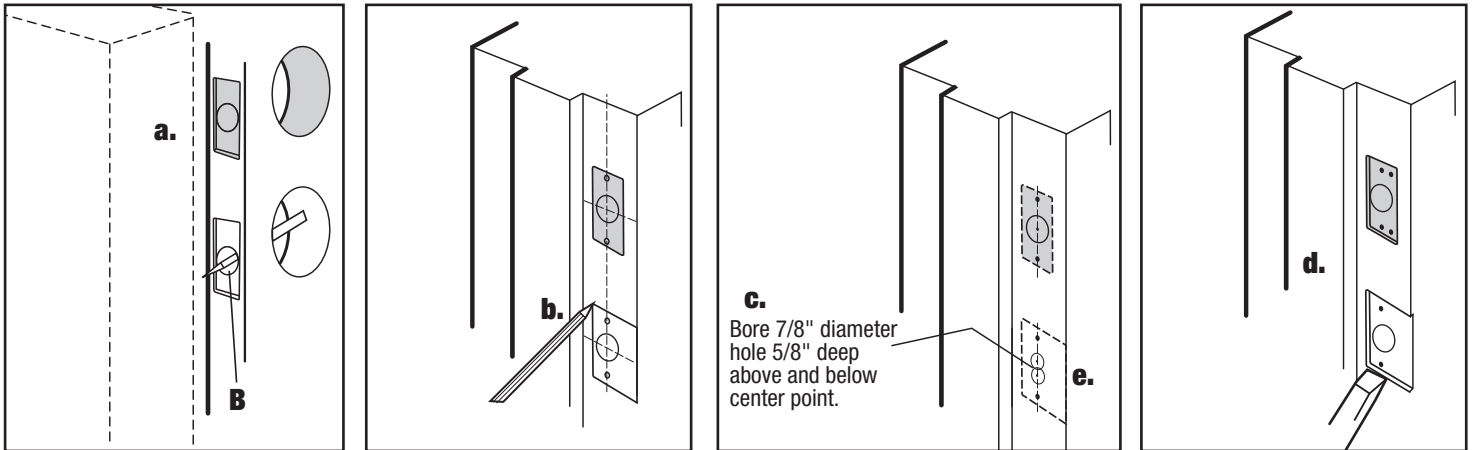

FOR DEADBOLT STRIKE PLATE, SEE SEPARATE DEADBOLT DOOR PREPARATION AND PRODUCT INSTALLATION INSTRUCTIONS.

FOR HANDLESET STRIKE PLATE (SEE 999-00370 STEP 10 FOR INSTALLATION INSTRUCTIONS)

- a)** With door closed, use a nail or marker through Hole B to mark center location of strike plate onto door jamb.
- b)** Using the curved strike plate as a template, outline plate onto door jamb.
- c)** Drill two 7/8" (22 mm) holes 5/8" (16 mm) deep above and below center location mark, barely overlapping each other. Chisel out remaining edge material.
- d)** Chisel out outlined area approximately 1/16" (1.6 mm) deep or until strike plate is flush.
- e)** Reposition strike plate, mark and drill pilot holes for screws.

CONFIRM THAT ALL HOLES HAVE BEEN PROPERLY PREPARED AND PROCEED TO THE HARDWARE INSTALLATION INSTRUCTIONS.

IF YOUR HANDLESET MODEL WAS PROVIDED WITH A DEADBOLT, SEE SEPARATE DEADBOLT DRILLING TEMPLATE.

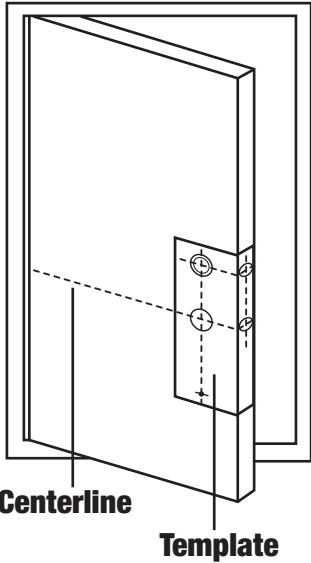

5-1/2"
140 mm
Minimum recommended distance.

IMPORTANT!
This line should be 5-1/2". Measure it before using this template. If the line is not 5-1/2" when measured, print this instruction out, full scale on paper that is 8.5" x 11" and measure again.

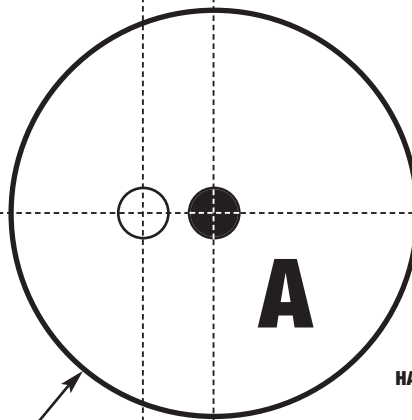
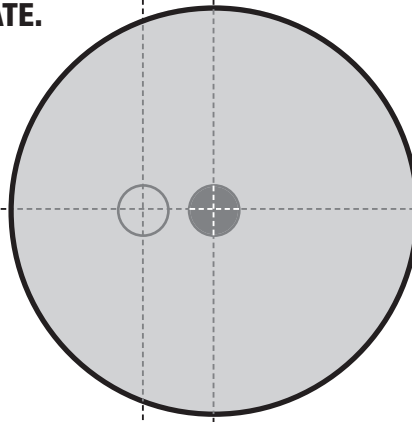

Drill 2-1/8" (54 mm) diameter hole through door for HANDLESET.

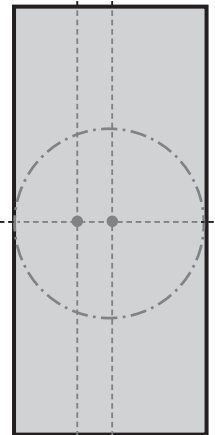

FOLD THIS LINE TO THE EDGE OF DOOR

CENTER MARK FOR:
1-3/4" (45 mm) Thick Door
1-3/8" (35 mm) Thick Door
Drill 1" (25.4 mm) hole for HANDLESET latch. Check door thickness before drilling!

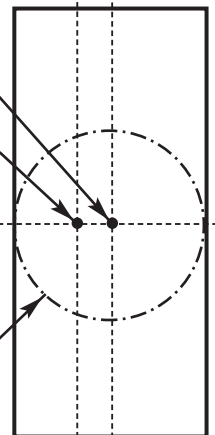

11/16"
17.5 mm

7/8"
22mm

**QUESTIONS? CALL
1-800-562-5625 FOR HELP.**

**TEMPLATE FOR HANDLESET INSTALLATION
OUTSIDE SURFACE OF LEFT HAND DOOR**

Drill 2-1/8" (54 mm) diameter hole through door for HANDLESET.

**38" (965 mm) from floor
(Suggested distance)**

Hole Diameters:

A = 2-1/8" (54 mm)

B = 1" (25.4 mm)

C = 5/16" (8 mm)

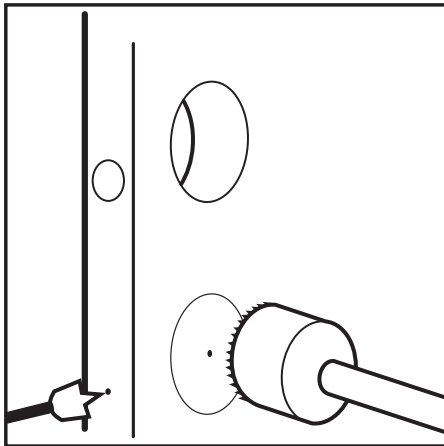
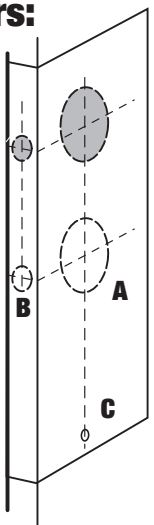

8-3/8" (213 mm)

IMPORTANT!
This line should be 8-3/8". Measure it before using this template. If the line is not 8-3/8" when measured, print this instruction out, full scale on paper that is 8.5" x 11" and measure again.

C

Drill 5/16" (8 mm) diameter hole through the door.

CENTER MARK FOR:

1-3/4" (45 mm) Thick Door

1-3/8" (35 mm) Thick Door

Drill 1" (25.4 mm) hole for HANDLESET latch. Check door thickness before drilling!

2-3/8" (60 mm) BACKSET

2-3/4" (70 mm) BACKSET

11/16" (17.5 mm)

7/8" (22mm)

FOLD THIS LINE TO THE EDGE OF DOOR

B

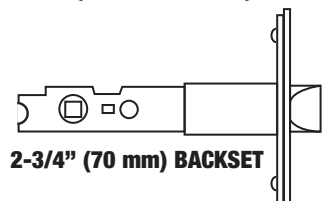
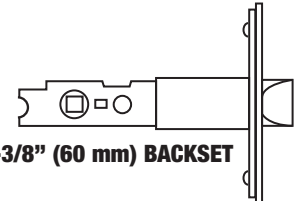
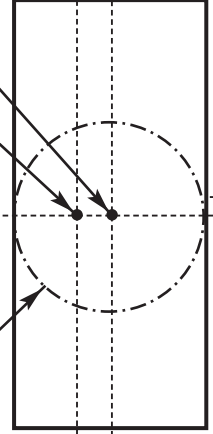
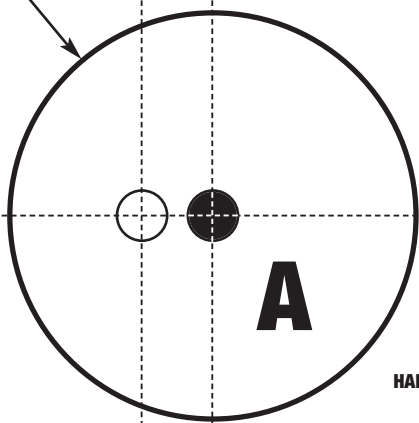

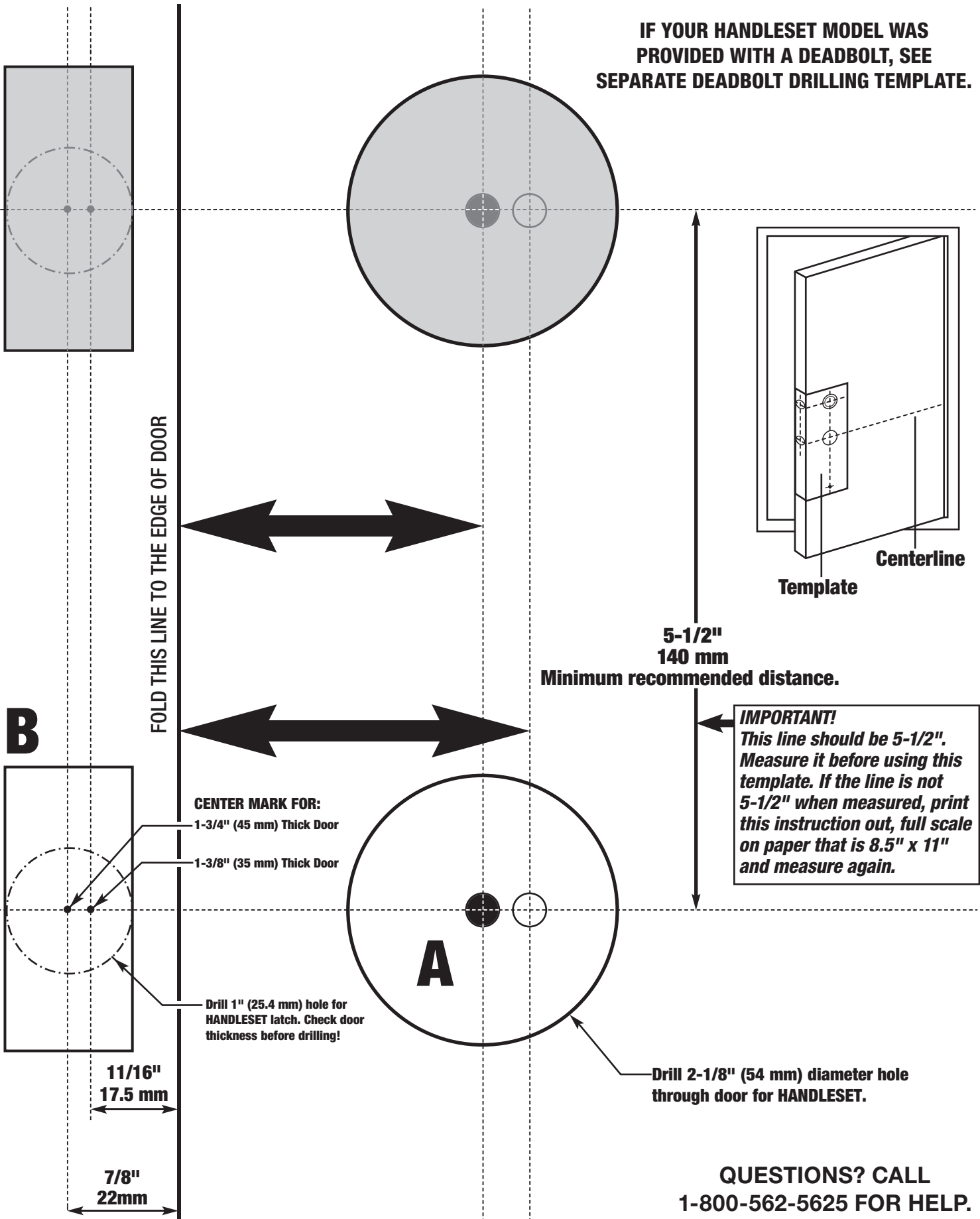

**TEMPLATE FOR HANDLESET INSTALLATION
OUTSIDE SURFACE OF RIGHT HAND DOOR**

B

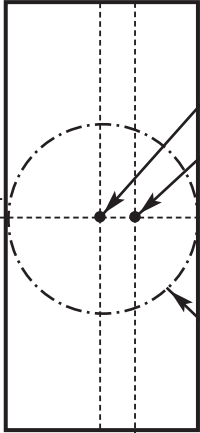

CENTER MARK FOR:
1-3/4" (45 mm) Thick Door

1-3/8" (35 mm) Thick Door

Drill 1" (25.4 mm) hole for
HANDLESET latch. Check door
thickness before drilling!

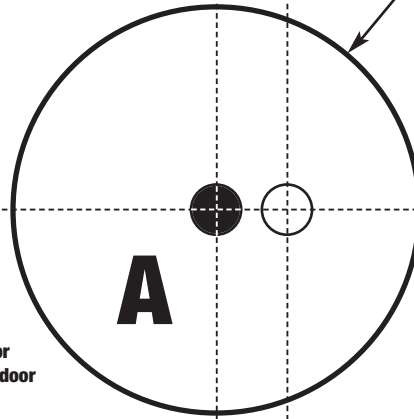

Drill 2-1/8" (54 mm) diameter hole
through door for HANDLESET.



**38" (965 mm) from floor
(Suggested distance)**

Hole Diameters:

A = 2-1/8"
(54 mm)

B = 1"
(25.4 mm)

C = 5/16"
(8 mm)

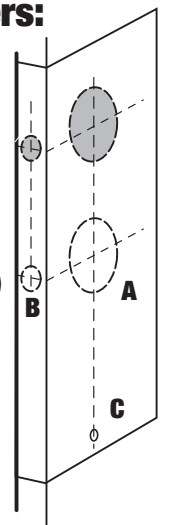

11/16"
17.5 mm

7/8"
22mm

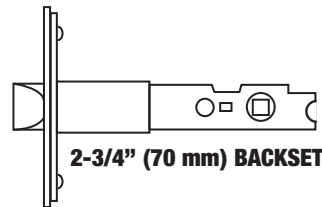
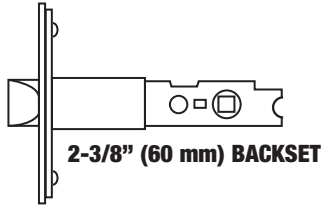

FOLD THIS LINE TO THE EDGE OF DOOR

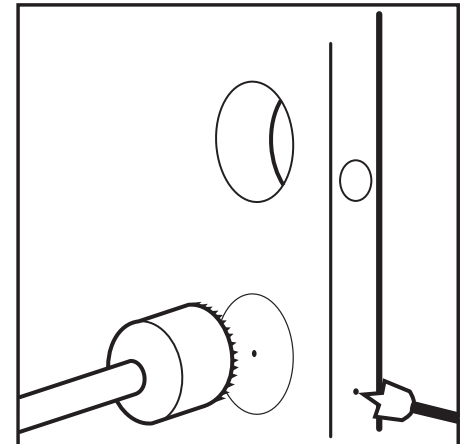

8-3/8"
213 mm

Drill 5/16" (8 mm) diameter
hole through the door.

C

IMPORTANT!

This line should be 8-3/8". Measure it before using this template. If the line is not 8-3/8" when measured, print this instruction out, full scale on paper that is 8.5" x 11" and measure again.

