



INSTALLATION & OPERATION INSTRUCTIONS FOR PUSH PULL ROTATE LEVER HANDLE LOCKSETS

999-00347E_EN

FOR EXTERIOR LOCKING KEYED ENTRY PUSH PULL ROTATE LEVER HANDLE LOCKSETS.

FITS DOORS 1-3/8" (35 mm) TO 1-3/4" (45 mm) THICK • WORKS FOR BOTH IN-SWINGING AND OUT-SWINGING DOORS. SEE STEP 2.

QUESTIONS? CALL 1-800-562-5625 FOR HELP.

Scan to watch installation video or go to www.brinksppr.com/install.shtml

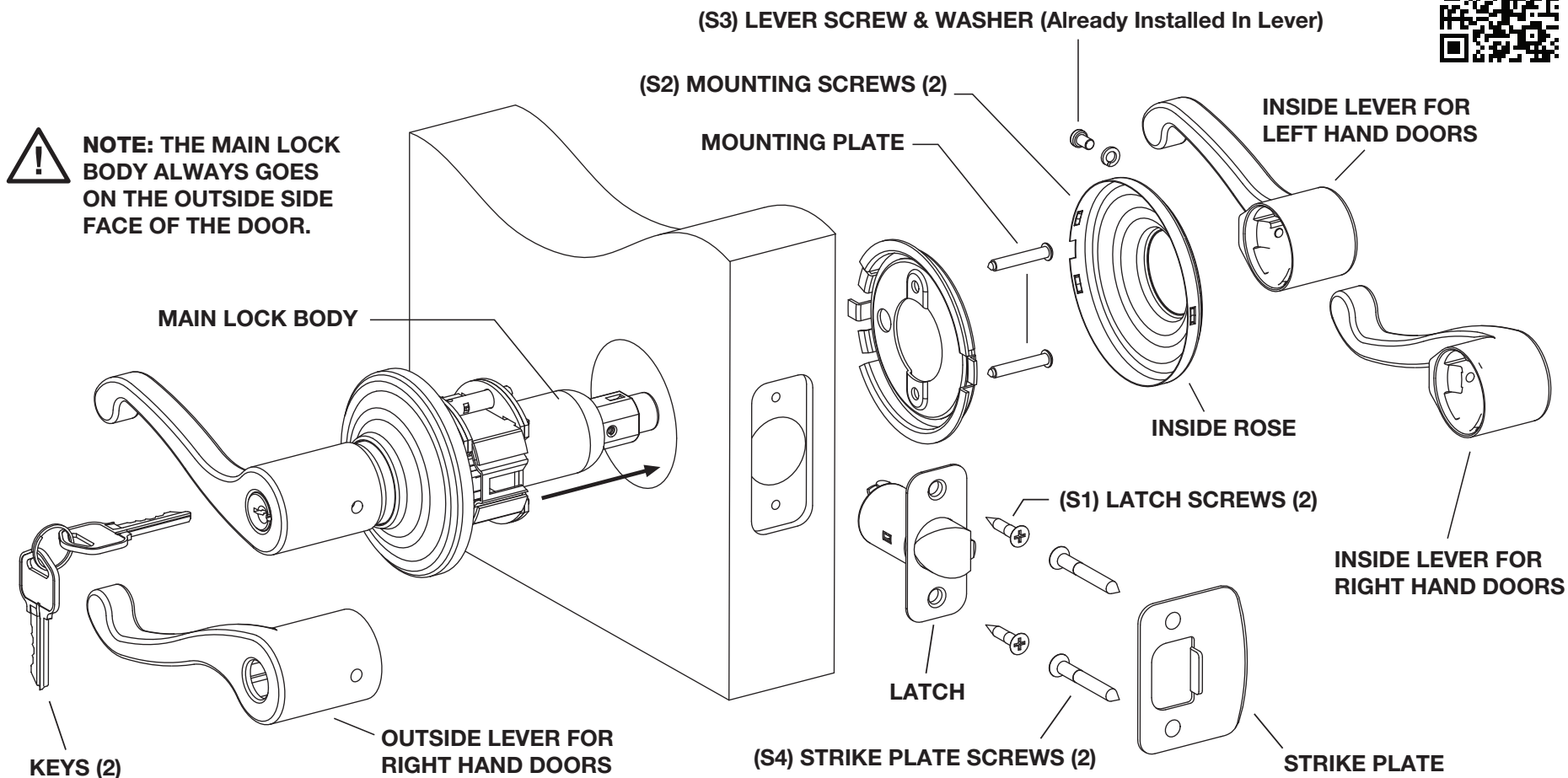

FOR NEW INSTALLATIONS, SEE INSTRUCTION 999-00321E_EN. FOR REPLACEMENT INSTALLATIONS, PROCEED TO STEP 1.

⚠ IMPORTANT!

STEP 1 Adjust For Door Thickness

- Measure your door thickness. It should be 1-3/8" (35 mm) or 1-3/4" (45 mm). If in between these numbers, round to the nearest of those two thicknesses.
- Your lockset is pre-set for a 1-3/4" door. If your door thickness is about 1-3/4", proceed to Step 2.
- If your door is closer to 1-3/8" (35 mm) thick, the position of the Outside Mounting Plate must be adjusted. It is held in place by two Screw Posts which have a hexagonal shape on the end; two Hex Adaptors are provided so that a Phillips Head Screwdriver can be used to quickly unscrew the two posts that hold the Mounting Plate.
- Slide the Mounting Plate back. Locate the Adjustment Ring and slide it back also.
- Rotate the Adjustment Ring until the two 35 mm notches on the ring are aligned with the two Lugs on the Main Lock Body. These Lugs are located in line with the Screw Posts.
- Slide the Adjustment Ring against the Lugs.

- Slide the Outside Mounting Plate back against the Adjustment Ring and secure it by screwing the two Screw Posts back into the Threaded Posts on the Mounting Plate, alternating between the posts so that they are tightened evenly. Tighten them both firmly.

Note: If the Hex Adaptors are lost, an adjustable wrench can be used to loosen and tighten the Screw Posts. Be careful not to over-tighten.

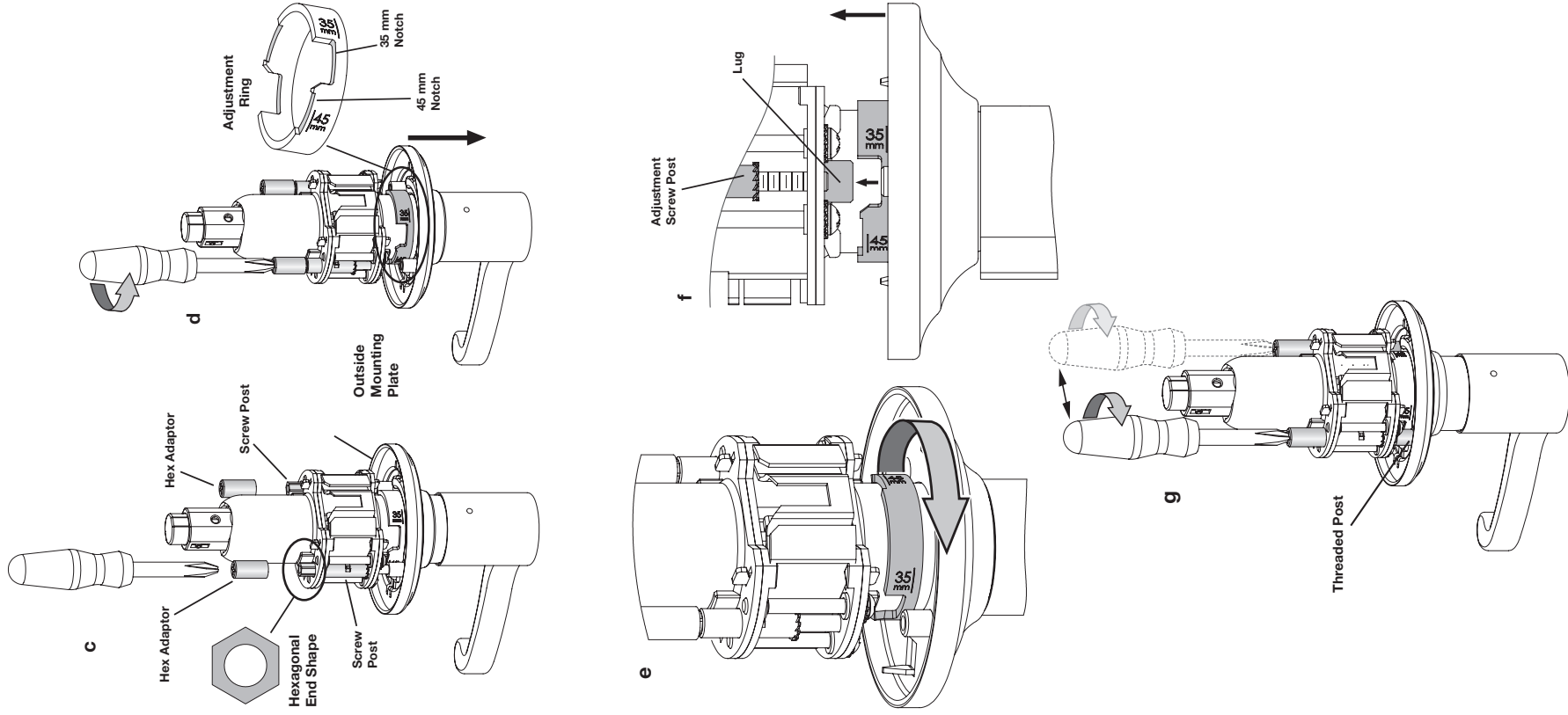

STEP 5 Install the Main Lock Body

- Insert the Main Lock Body through the 2-1/8" (54mm) hole in the door.
- Look through the hole from the inside of the door to guide the Main Lock Body.
- Make sure that the Cylindrical Case engages with the Latch Prongs and the Retractor interlocks with the Latch Tail.
- Test by rotating the lever - the latch bolt should retract.

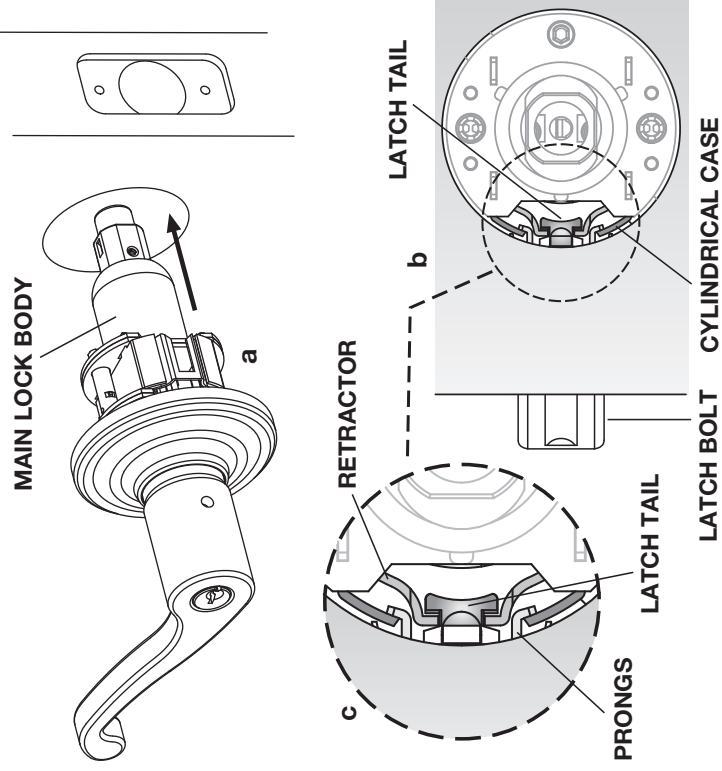

STEP 6 Install the Inside Mounting Plate and Rose

- Place the Inside Mounting Plate over the Main Lock Body and against the inside door face with the mounting holes aligned vertically. Position the mounting plate so it reads 'FACE OUT' when it is against the door.
- Insert the two (S2) Mounting Screws and engage the threaded holes in the Main Lock Body. Tighten firmly.
- Install the Inside Rose by aligning with the notches on the Mounting Plate and snapping it on.

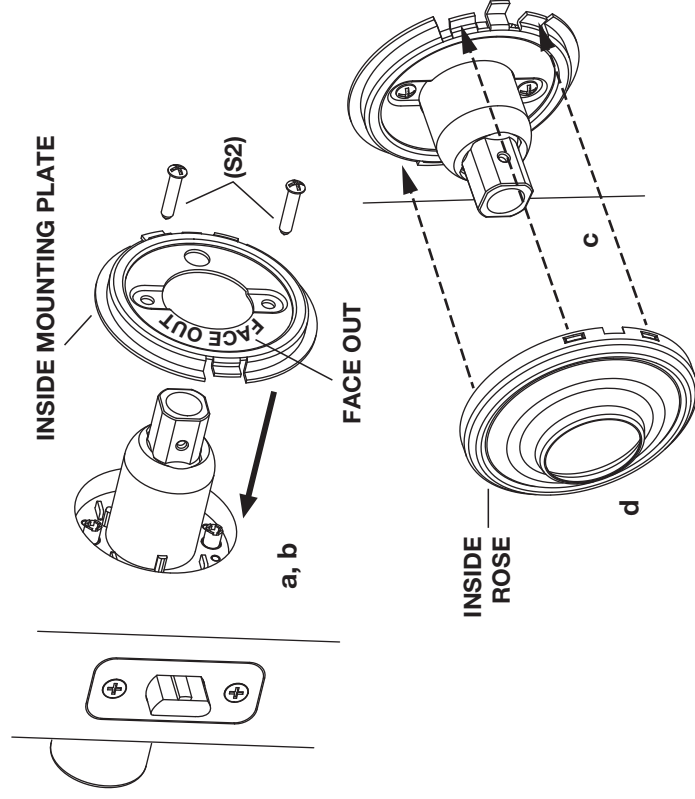

STEP 7 Install Inside Lever

- Push the Inside Lever onto the Spindle until it stops.
- Tighten the (S3) screw located on the inside of the lever. The screw will engage the hole in the Spindle.
- Test installation by pushing, pulling and rotating the lever.

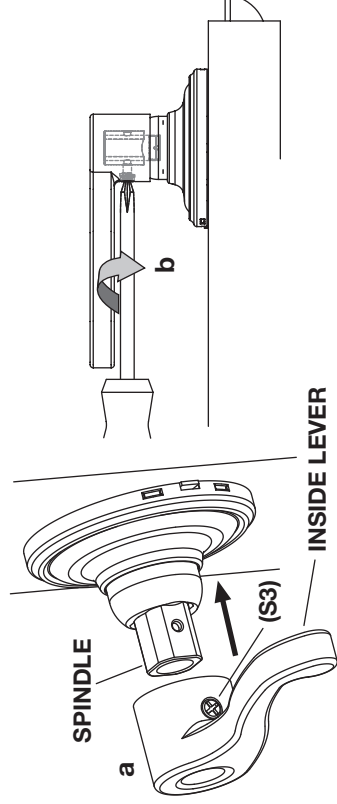

STEP 8

Install Strike Plate

- a. Secure the Strike Plate with two (S4) Strike Plate Screws. Tighten firmly. Make sure that the Deadlocking Plunger is depressed by the Strike Plate and does not enter the hole in the plate.
- b. It is important for Push-Pull-Rotate Locks for the Latch Bolt to move freely in and out of the Strike Plate.

LATCH BOLT

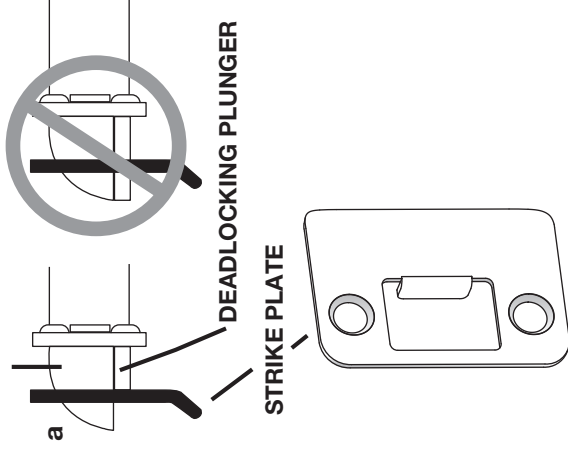

STEP 9

Operation & Troubleshooting

PUSH-PULL Lever Operation

- a. Always **PUSH** or **PULL** the lever near the end as shown for best results.

In-Swinging Doors

- b. To open the door from the outside, **PUSH** the outside lever or rotate the lever in either direction.

- c. To exit the room, **PULL** the inside or rotate the lever in either direction.

Out-Swinging Doors

- d. To open the door from the outside, **PULL** the outside lever or rotate the lever in either direction.

- e. To exit the room, **PUSH** the inside lever or rotate the lever in either direction.

To Lock

- f. **PUSH** the button to lock. The lever cannot be locked with the key. To unlock use the key or operate the inside lever.

Troubleshooting

- g. The **PUSH** and **PULL** functions work best when the latch bolt can move freely in and out of the Strike Plate.

- h. Weather stripping or a warped door can sometimes force the bolt against the Strike Plate. This will increase the force necessary to **PUSH** or **PULL** the lever. For best results, re-position the Strike Plate so there is no force against the bolt.

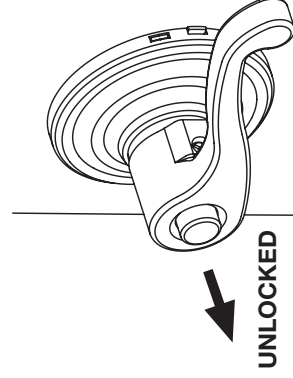
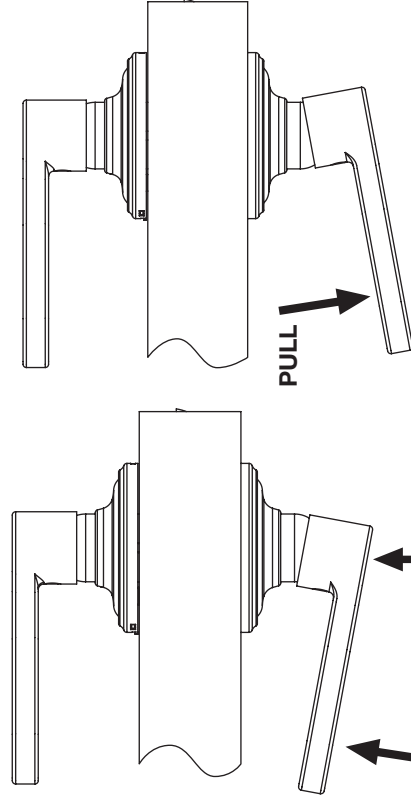

LIMITED LIFETIME WARRANTY- This product is warranted by Hampton Products International ("HPI") with a limited lifetime mechanical and finish warranty to the original consumer user of this product against defects in material and workmanship under normal use and service as long as the original consumer user occupies the residential premises upon which this product was originally installed. This warranty does not apply to product used in commercial or common area applications; used for purposes for which it was not designed or intended; and which has been abused, misused, modified, or improperly installed, operated, maintained, and/or repaired. This warranty does not cover scratches, abrasions, or deterioration due to the use of paints, solvents, or other chemicals. HPI IS NOT LIABLE FOR INCIDENTAL, INDIRECT, OR CONSEQUENTIAL DAMAGES. Some states do not allow the exclusion or limitation of incidental or consequential damages, so the above exclusion may not apply to you. This warranty provides you with specific legal rights and you may also have other rights that vary from state to state. To make a warranty claim, please contact Hampton Care at 1-800-562-5625 or visit our website at www.hampton.care for instructions on how to have the product replaced, exchanged for a similar product of equal value, or repaired.



BRINKS A TRUSTED NAME IN SECURITY SINCE 1859 and all related logos are trademarks or registered trademarks of Brink's Network, Inc. and are used with permission.

HAMPTON
50 Icon, Foothill Ranch, CA 92610-3000 EE. UU.
email: info@hamptonproducts.com
www.brinkspr.com 1-800-562-5625
©2019 Hampton Products International Corp.
999-00347E_EN_REVB 10/19

999-00347E_EN