



Manufactured according to OIML R60 standards

Capacity from 50 kg to 300 kg

Capacity from 500 kg to 5000 kg



- AISI 420 STAINLESS STEEL
- COMBINED ERROR  $\leq \pm 0.03\%$
- PROTECTION CLASS IP67

CAPACITY	kg	IECEx	Ex	EAC Ex	EAC	NET WEIGHT (kg)	CODE
50		•	•	•		0.7	CTOL50
100		•	•	•		0.7	CTOL100
200		•	•	•		0.7	CTOL200
300		•	•	•		0.7	CTOL300
500		•	•	•		0.7	CTOL500
1000		•	•	•		1.4	CTOL1000
2500		•	•	•		1.4	CTOL2500
5000		•	•	•		2.7	CTOL5000

ON REQUEST

### CERTIFICATIONS

**EAC** Complies with the Eurasian Custom Union standards

CERTIFICATIONS ON REQUEST

**Ex** ATEX II 1GD (zone 0-1-2-20-21-22)

**IECEx** IECEx (zone 0-1-2-20-21-22)

**EAC Ex** Complies with the Eurasian Custom Union standards for use in potentially explosive atmospheres

### COMPLEMENTARY ACCESSORIES

	DESCRIPTION	CODE
	Dimensions: Special steel ball-and-socket joint with nut.	Load cell capacity:
	M12x1.75	50-500 kg EM12DADO
	M16x2	1000 kg EM16DADO
	M20x1.5	2500 kg EM20DADO
	M24x2	5000 kg EM25DADO

### DIMENSIONS (mm)

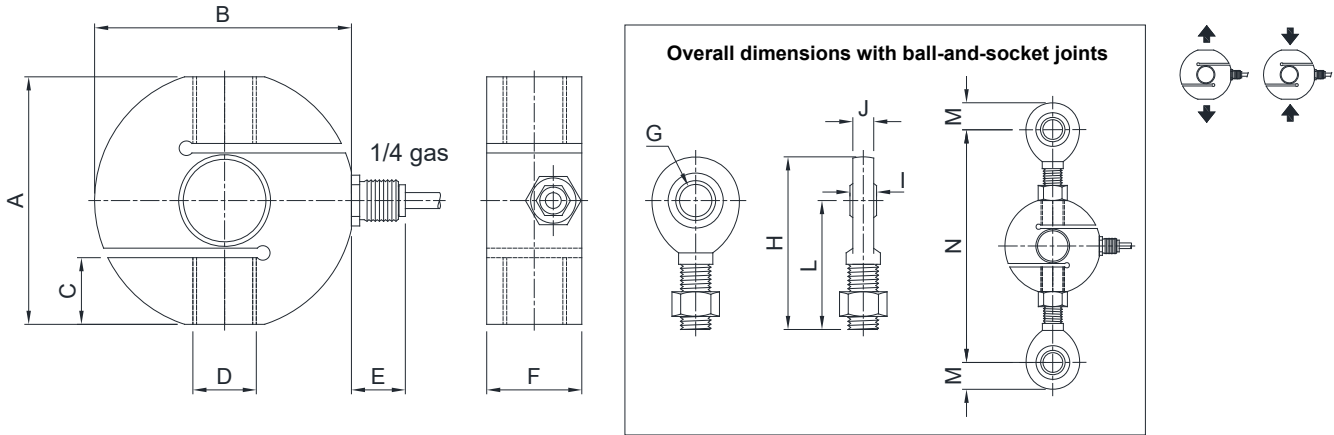

	A	B	C	D	E	F	G	H	I	J	L	M	N (≈)
50 kg 500 kg	59.5	63.5	14.5	M12x1.75	17	22	Ø12	71	10	8.5	54.5	16.5	140
1000 kg	78	82	21	M16x2	17	30	Ø17	92	14	11.5	69.5	22.5	176
2500 kg	78	82	21	M20x1.5	17	30	Ø20	104.5	16	13.5	77.5	27	191
5000 kg	90	102	24	M24x2	17	45	Ø25	126	20	17.5	94.5	31.5	230

### TECHNICAL FEATURES

Material	AISI 420 stainless steel		
Nominal load (E max)	50 - 100 - 200 - 300 - 500 - 1000 - 2500 - 5000 kg		
Combined error	≤ ±0.03%		
Protection class	IP67		
Rated output	2 mV/V ±0.4%	Input resistance	385 Ω ±30
Temperature effect on zero	0.0025% °C	Output resistance	350 Ω ±10
Temperature effect on span	0.0025% °C	Zero balance	±2%
Compensated temperature range	-10 °C / +40 °C	Insulation resistance	>2000 MΩ
Operating temperature range	-20 °C / +60 °C	Safe overload (% of full scale)	150%
Creep at nominal load in 30 minutes	0.03%	Ultimate overload (% of full scale)	250%
Max supply voltage without damage	15 V	Deflection at nominal load	0.4 mm

### ELECTRICAL CONNECTIONS

Cable length	10 m
Cable diameter	6 mm
Cores	6 x 0.20 mm <sup>2</sup>

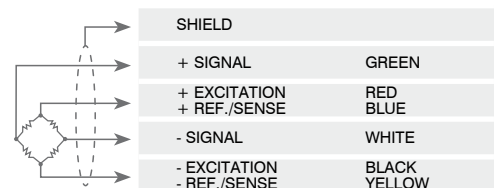

The Company reserves the right to make changes to the technical data, drawings and images without notice.