



F68/220 - IMC Vulture 826 Free-standing Food Waste Disposer - 3 Phase [5 wire] - W 430 mm - 2.2 kW

Reliable, efficient, safe and easy to operate, the 826 Waste Disposer allows operators to quickly and effectively remove waste, to create a safer and cleaner kitchen.

- ✔ Fast and efficient disposal of up to 600kg of food waste per hour.
- ✔ Handles up to 1350 covers per sitting - ideal for large kitchens.
- ✔ For tough waste (red meat bones, cauliflower stalks and fish skins).
- ✔ Compact, free-standing design, for quick and easy loading.
- ✔ Manually reversible motor to extend operational life.
- ✔ Suitable for large kitchens with three-phase, five-wire power supply.

Specifications

Summary

Brand	IMC
Range	Vulture
Series	800 Series
Power Type	Electric
Unit Type	Free-standing
Available in UK Only	No
UK Warranty	2 Years Parts and Labour Warranty
Export Warranty	Contact your local dealer
Mounting	Free-standing
GTIN	5056105199328

Power and Performance

Total Power kW	2.2
HP	3
IP Rating	IP55

Key Specifications

Operator Safety	Interlocks
Airbreak	No

Capacity

Type of Waste	Tough waste
Covers Per Sitting	1350
Capacity Kg per Hour	600

Weights and Dimensions

Unit Height (External) mm	850
Unit Width (External) mm	430
Unit Depth (External) mm	600
Net Weight Kg	64.5

Supply Connections

Requires Installation	Yes
Requires Electrical Supply	Yes
UK 3 Pin Plug	No
Requires Hardwiring	Yes
Electrical Supply Rating Watts	2200
Three Phase Amps	5.3
Three Phase Voltage	400
Water Supplied From	Storage cistern
Water Connection Pressure Bar	0.4
Drain Connection	2" BSP threaded flange, connected to 54mm piping;
Water Connection	15mm

Shipping

Packed Weight Kg	70.95
Packed Height cm	104
Packed Width cm	63
Packed Depth cm	48

Available Options

SIDE PANEL

E68/013 826 SIDE PANEL

MAG CUTLERY SAVER

VS167 700/800/904/904X MAGNETIC CUTLERY SAVER

REMOTE CONTROL BOX

VS258 825 DUMP STATION/826 REMOTE CONTROL BOX

WATER FLOW CONTROL

VS358 826 WATER FLOW CONTROL

Technical Picture

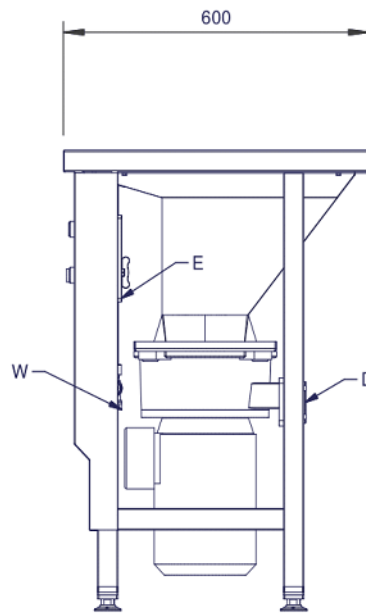
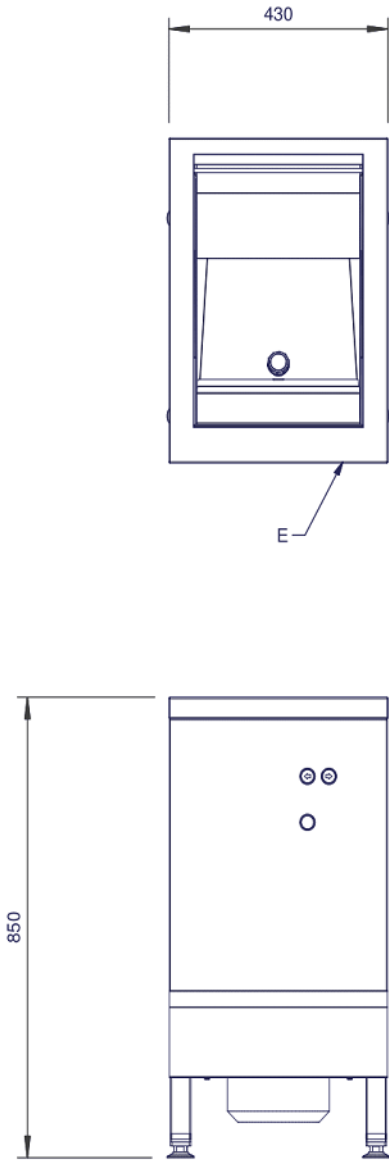

Lincat Limited

Whisby Road,
Lincoln, LN6 3QZ,
United Kingdom

Company No: 2175448

A member company of



Customer Care

Tel: +44 1522 875500

Email: care@lincat.co.uk

Export Customers

Tel: +44 1522 875536

Email: export@lincat.co.uk

Opening Hours

Monday – Friday:

8.30am – 5pm