

Note: Ref dimensions only need to be verified for set-up and FAI purposes.

Customer: _____ MFG P/N: _____
 Project Code: _____ Customer P/N: _____
 W/O Number: _____ S/N: _____
 Lot: _____
 D/C: _____

PACKAGE TYPE:

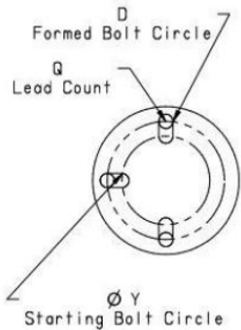
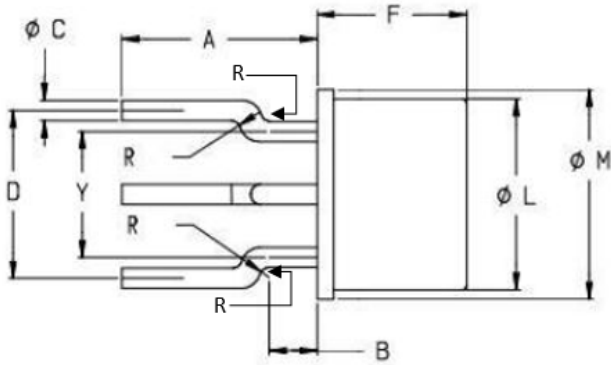

(check one from each category)

Leads
Tinned As Received: Yes No
Leads To Be Tinned: Yes No

Inspection Sample: _____ Of _____

Inspection Data	Unit (check one):	<input type="checkbox"/> mm	<input type="checkbox"/> inches	Notes
	Requirements	Dim.	Tol. +/-	
A				Measured @ 3 places
B				Measured to Radius C/L in 3 places
C				Ref Dimension
D				Ref Dimension
F				Ref Dimension
R				Measured @ 6 places
L				Ref Dimension
M				Ref Dimension
Y				Ref Dimension
Q		N/A		Ref Dimension

Results Accepted

Tool # _____

Inspected By: _____

Date: _____