

1 Overview

2 Setting up your artwork

3 Designing your artwork

4 Checking, saving and sending

5 Artwork size guide

- 1) X Display - Landscape Mode
- 2) X Display - Portrait Mode
- 3) X Display - Landscape Mode + Printer Option
- 4) X Display - Portrait Mode + Printer Option
- 5) Scan Station
- 6) Selfie Station
- 7) X Display Brochure Holders
- 8) Sign Panel
- 9) Faceplate Logos

1 X GRAPHICS OVERVIEW

- 1 **Printing**
We engage the services of third party digital printing house for all X Solution branding options.
- 2 **Material**
Panel artwork is digitally printed onto self adhesive vinyl which is then adhered to a 0.5mm PVC Sheet (X Display, Scan Station + Selfie Station) or 3.0mm Forex Sheet (Sign Panel). The dress face of the artwork is also protected by a lightly textured clear laminate. A direct printing process is used to place logos on Enclosure Faceplates.
- 3 **Artwork Errors and Corrections**
We recommend that you thoroughly check your artwork before submitting it for printing using the attached checklist as a guide. Once artwork is received it will be printed as supplied with no further checks or adjustments. If errors are detected after your artwork has been released to the printer, a re-print fee will apply.
- 4 **Proofs**
While print proofs are not supplied as part of our standard X Display build process, we can supply an A3 proof sheet of your selected artwork elements on request for an additional fee. Please note that the production of the proof sheet can also add 5-7 days to the production lead-time of your product build.
- 5 **Archiving of Artwork**
Generally, your artwork is deleted from our server after project completion and you will be requested to resupply it for future duplicate orders. Exceptions apply (on request) for customers ordering the same graphics on a regular basis.
- 6 **Accepted File Size**
No larger than 50MB
- 7 **Accepted File Formats**
Logos - EPS
X Display Artwork - Press Quality PDF

2 SETTING UP YOUR ARTWORK

1 Set Your Overall Artwork Size (Supply Size)

Your X Graphic Panels will be supplied as a set or individually depending on your selected product model or re-print requirements. For example, the X Display set consists of 3 Panels - the Front Upper, Front Lower and the Back.

The artwork you will supply for each panel needs to be saved as

- 1) Separate PDF files [ie one PDF per panel]
- 2) to an exact overall size (summarised below)

Exact overall size (inc bleed) of each panel you will supply to Sprocket:

1) Front Upper Panel	W 278 x H 385mm
2) Front Lower Panel (inc Standard or Scan Options)	W 278 x H 1005mm
3) Back Panel	W 278 x H 1502mm
4) Front Lower Panel (Selfie Station)	W 278 x H 1380mm
5) Sign Panel	W 310 x H 310mm

Any artwork that does not match these exact dimensions cannot be accepted.

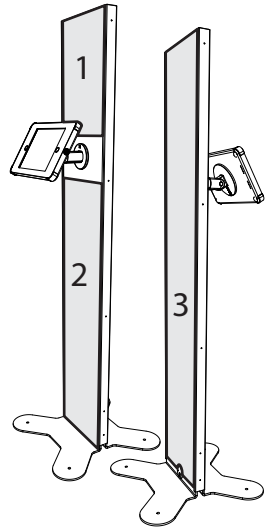

2 Set your Bleed Zones

Please allow a 5mm bleed (or overprint) zone inset from all four edges of the quoted panel sizes above. The bleed zone ensures your designs will run edge to edge with no white borders and will be trimmed off during panel production. If you choose to set up your bleed during the PDF print / export process (see Creating a Press Quality PDF) set your document size to the finished (trimmed) size of panels and set bleed to 5mm on each edge.

Your supplied artwork will be trimmed to the following sizes:

1) Front Upper Panel	W 268 x H 375mm
2) Front Lower Panel (inc Standard or Scan Options)	W 268 x H 995mm
3) Back Panel	W 268 x H 1492mm
4) Front Lower Panel (Selfie Station)	W 268 x H 1370mm
5) Sign Panel	W 300 x H 300mm

5mm Bleed Each Side

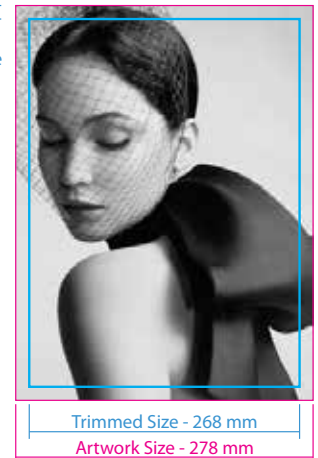

Set your Safe Zones

Depending on your order specification and tablet enclosure size and orientation, you might find that parts of your graphic panels are covered or difficult to see clearly when the product is assembled and/or is in use. For example, the X Display panels are held in position by the pillar side rails which cover an additional 5mm on each side of the artwork panels. Any design elements placed within this space will not be visible once assembled. We recommend that you use the Safe Zones outlined in this document as guidelines when placing important graphic elements in your designs to ensure maximum visibility.

No Trim Mark

Please do not include crop marks in your files. They will be added as part of the print setup process which is why it is important to save your files to the exact overall dimensions requested.

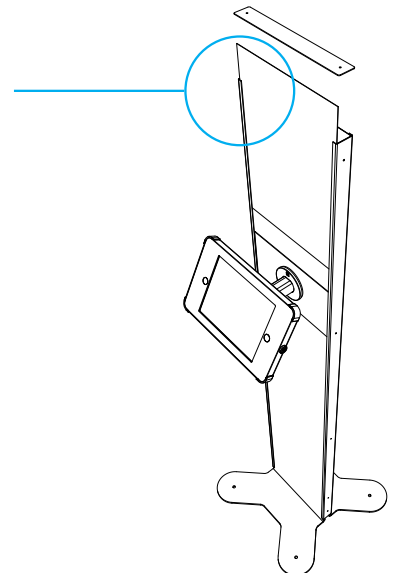

3 DESIGNING YOUR ARTWORK

1 Recommended Programs

Adobe software is the industry standard for professional graphic design. Packaged together as the Adobe Creative Suite, Illustrator, Photoshop and InDesign are the powerful trio that create most of the printed marketing materials worldwide.

When laying out your X Display panel artwork, vector art is generally the preferred art format, especially for typography and logos.



2 Colour Mode

Always design in CMYK colour space when making print ready artwork.



3 Colour Matching

Unless your computer monitor is specifically calibrated, there is the potential for the colours selected onscreen to appear slightly different when digitally printed. For specific block colour matching, we recommend Pantone Color Charts (available in both solid and process colors) are referenced and their values specified with your artwork to ensure our printers can achieve the closest possible match.



4 Resolution + Scale

If you'd like to incorporate images in your artwork layouts, we recommend that they are high quality (min 300dpi) and placed within the document at the intended print scale. Increasing placed (or linked) files to a larger scale within the document can distort the images and result in a pixelated print quality.



5 Fonts

Supplying your artwork as a PDF ensures that all fonts used are embedded in the supplied file.



6 Rich Black

When developing your artwork, if you are after a rich black colour across a large area or text over an image, we recommend the CMYK values are set to C:60, M:40, Y:40, K:100

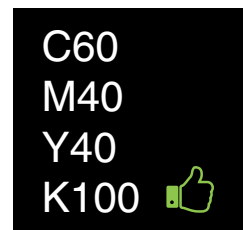

4 CHECKING, SAVING AND SENDING YOUR ARTWORK

1 Please check the following before saving your artwork for print

- Colour Mode is set to CMYK
- Overall panel size dimensions are correct
- Bleed and Safe Zone areas are correct
- Images are high resolution and not distorted
- Text has been proof-read and spell checked
- NO trim marks visible
- Files are saved as Press Quality PDFs [one per panel]
- File sizes are not larger than 50MB
- Pantone Swatch References have been noted (where applicable)

2 Creating a Press Quality PDF file

Depending on what design software you are using, exactly HOW you save to PDF can vary. Your particular software may be capable of one, two, or all three of these methods:

FILE > SAVE AS FILE > EXPORT FILE > PRINT

Regardless of the creation method, it is critical that your native document is set up correctly before you make the PDF and then for the following options to be selected / checked:

1) Quality

Most programs will give you several options as to the quality of the file. When making a PDF for professional printing it is very important that you select Press Quality.

2) Marks + Bleeds

Uncheck the Trim Mark option.

Check that your Bleed Settings are set to 5mm on each side.

3) Media + Document Size

Check that the Media Size matches the Overall Panel Size outlined in Step 1.

Check that the Document Size matches the Finished Artwork Size outlined in Step 2.

3 Transferring your files

If the file sizes are small enough (around 5 MB or less), you can simply email your artwork to studio@sprocket.com.au

Note - Compressing your files with WinZip or other software can drastically reduce file sizes for emailing.

For larger files, upload your art to DropBox, or a similar system for sharing large files, and share the link.

5 X DISPLAY CONFIGURATIONS

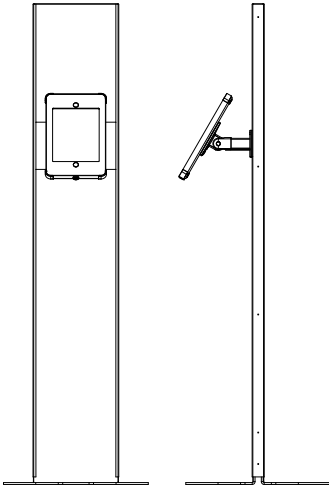

X Display - Portrait Mode

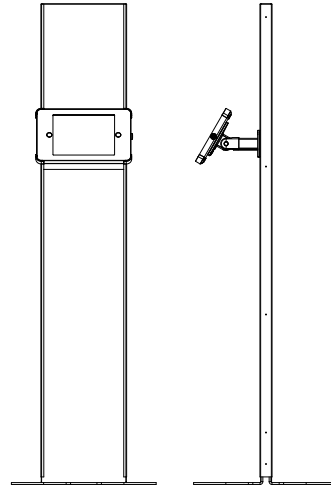
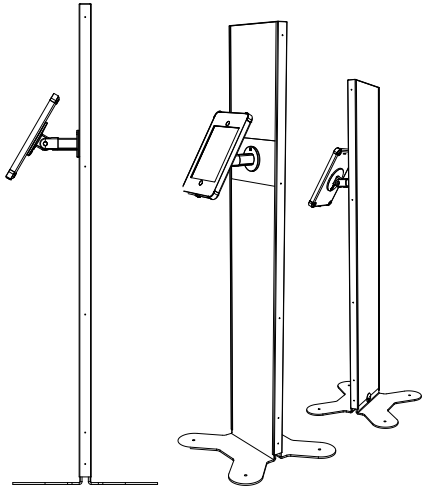

X Display - Landscape Mode

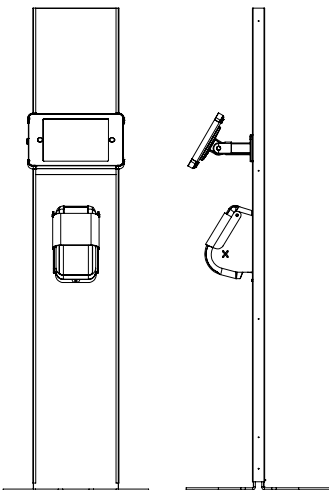
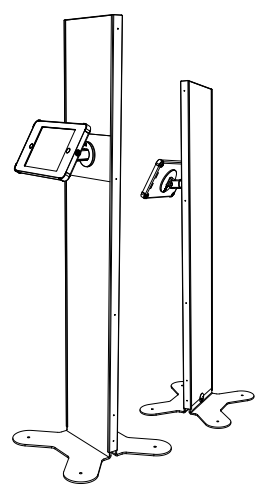

X Display + Printer Option

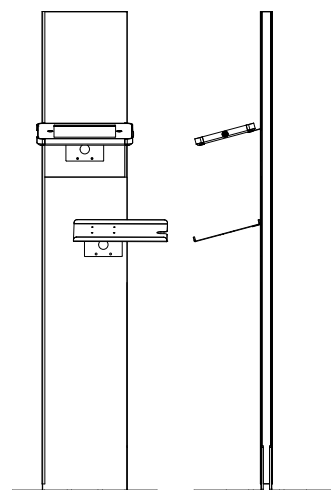
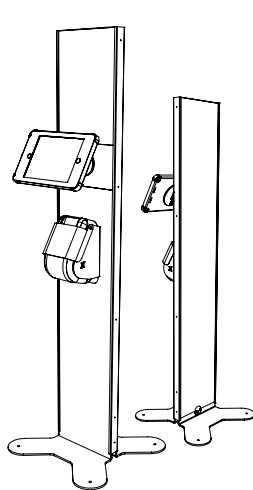

Scan Station

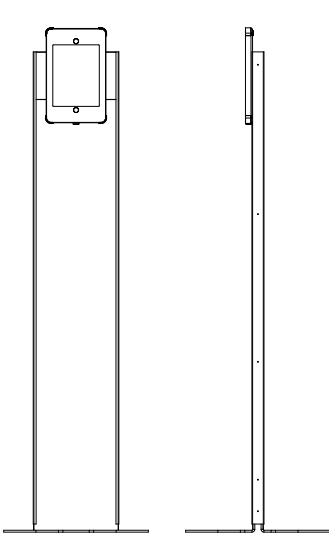
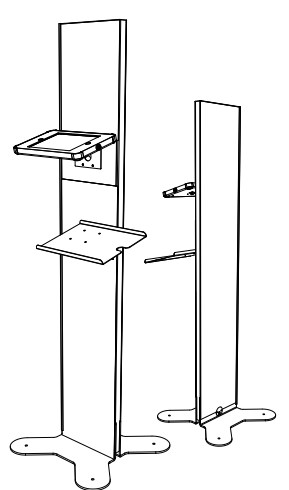

Selfie Station

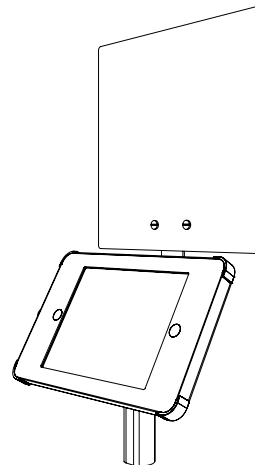
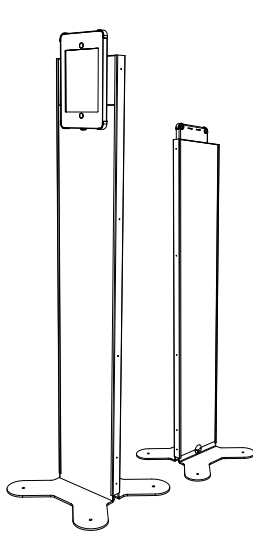

Sign Panel (for Desk, Wall or Floor Models)

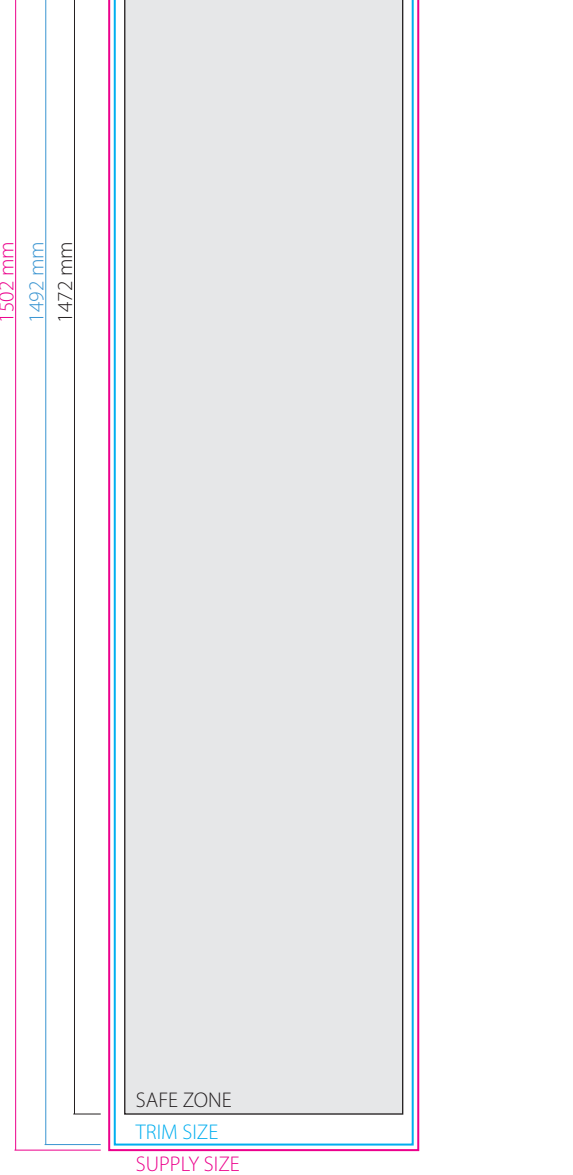
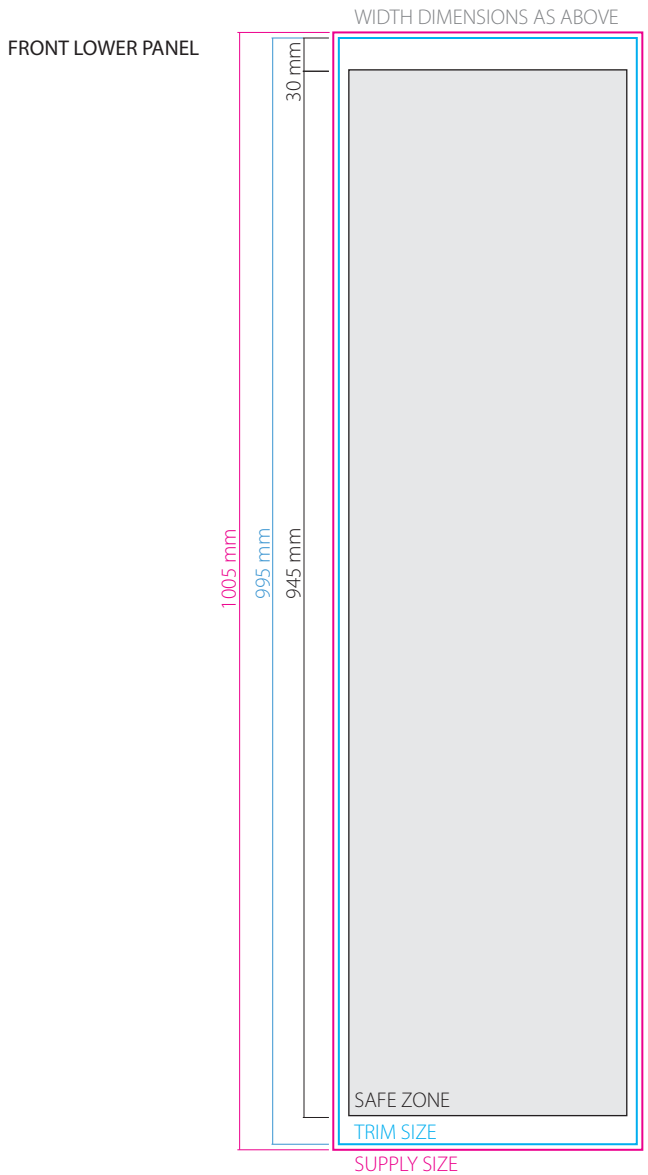
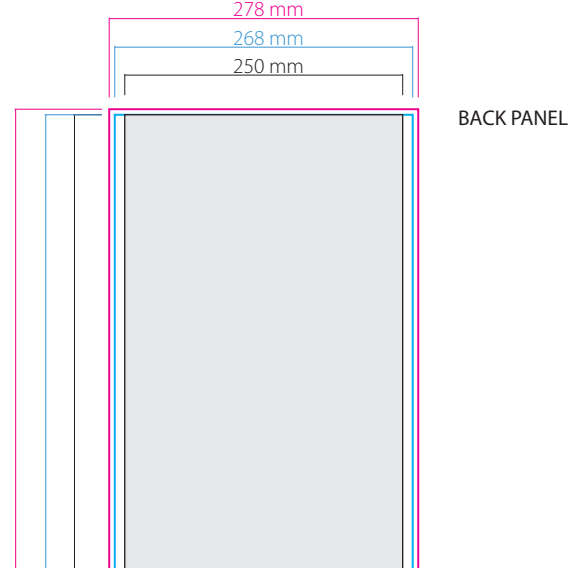
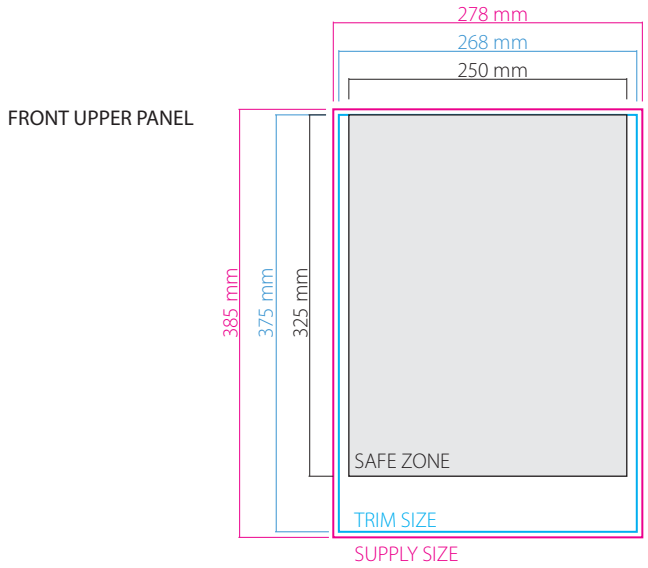

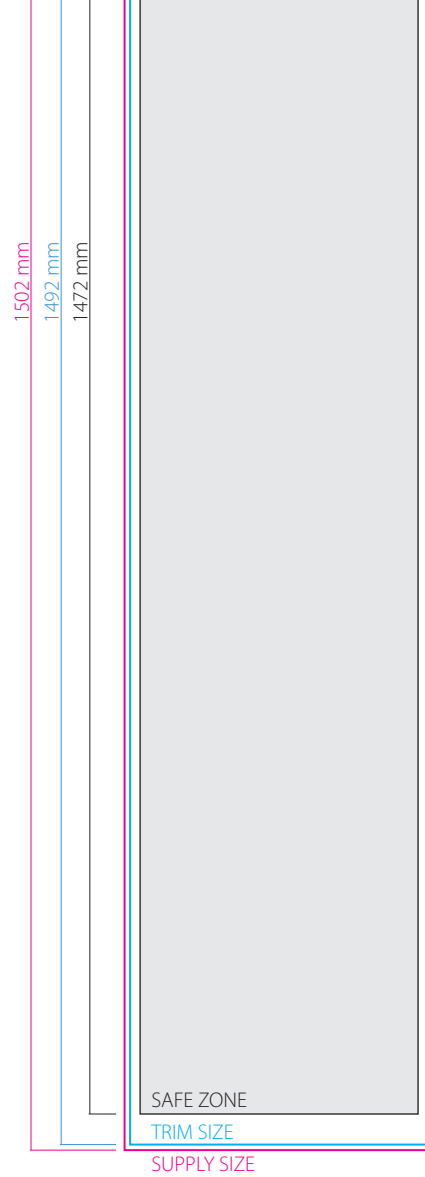
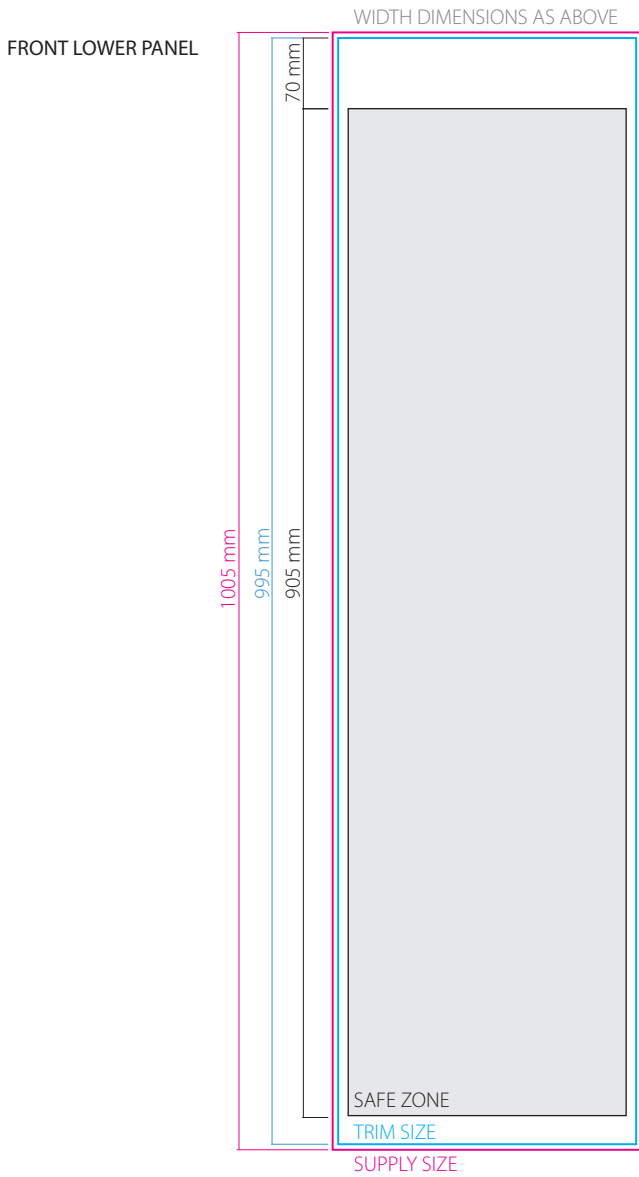
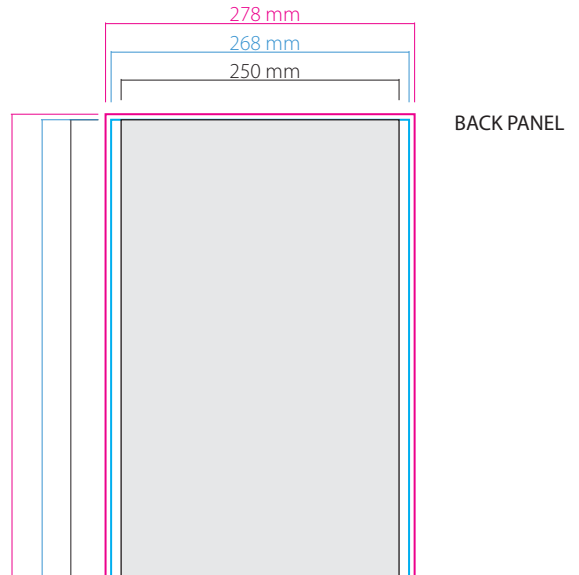
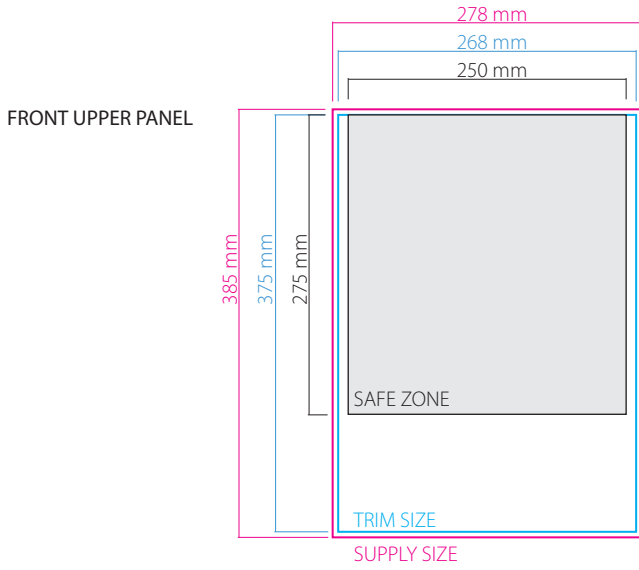

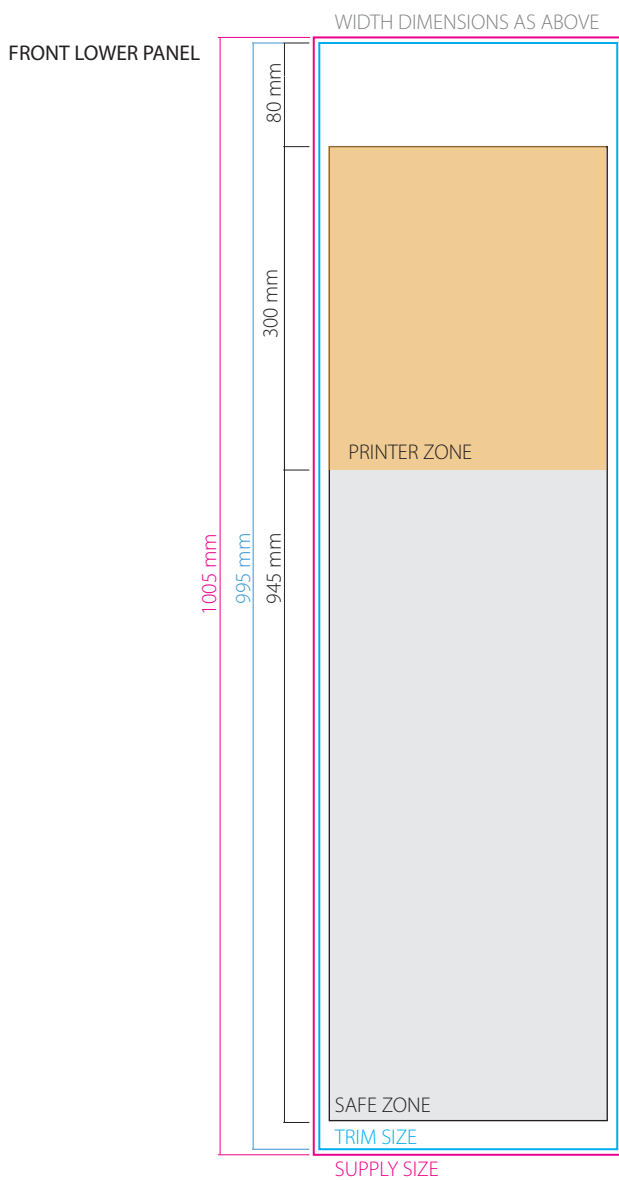
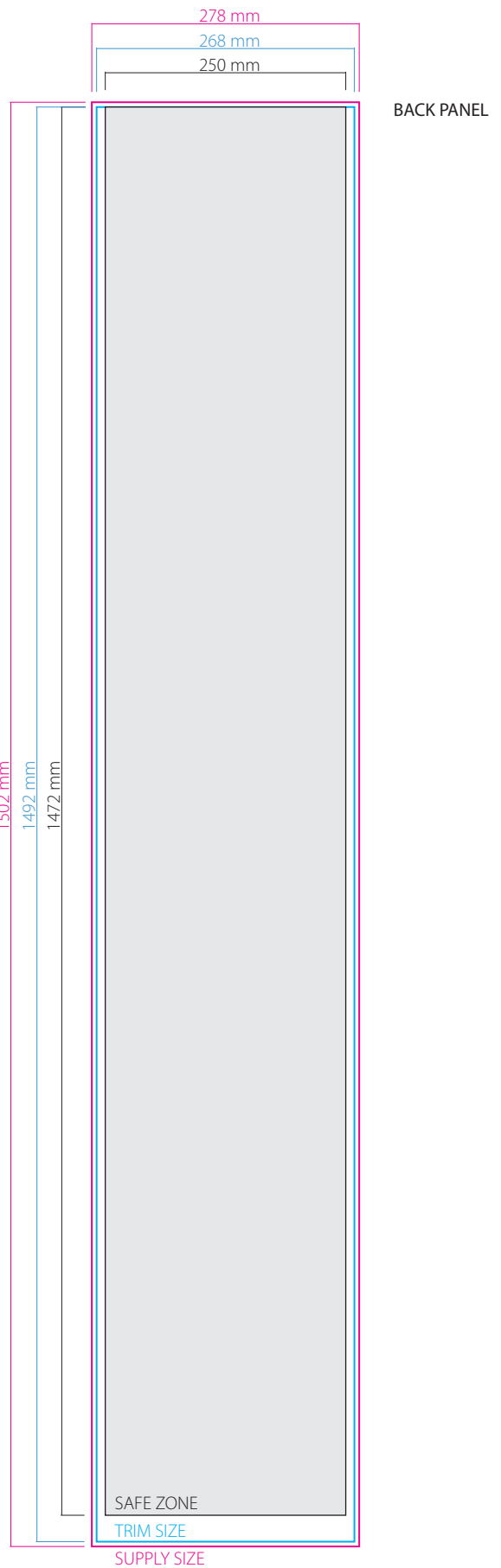
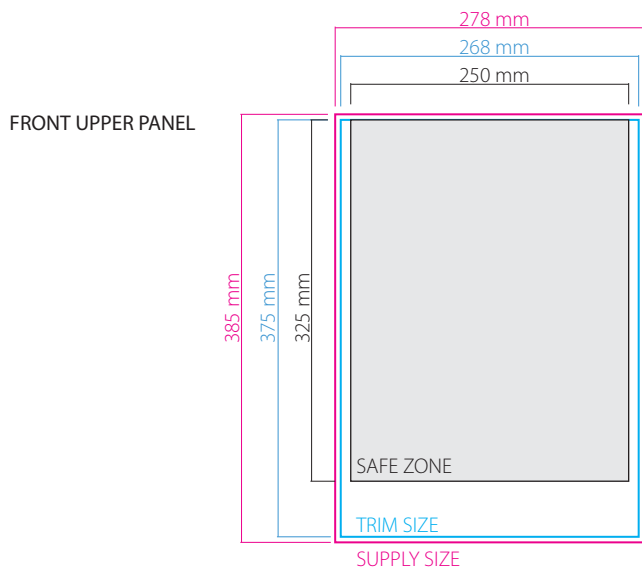

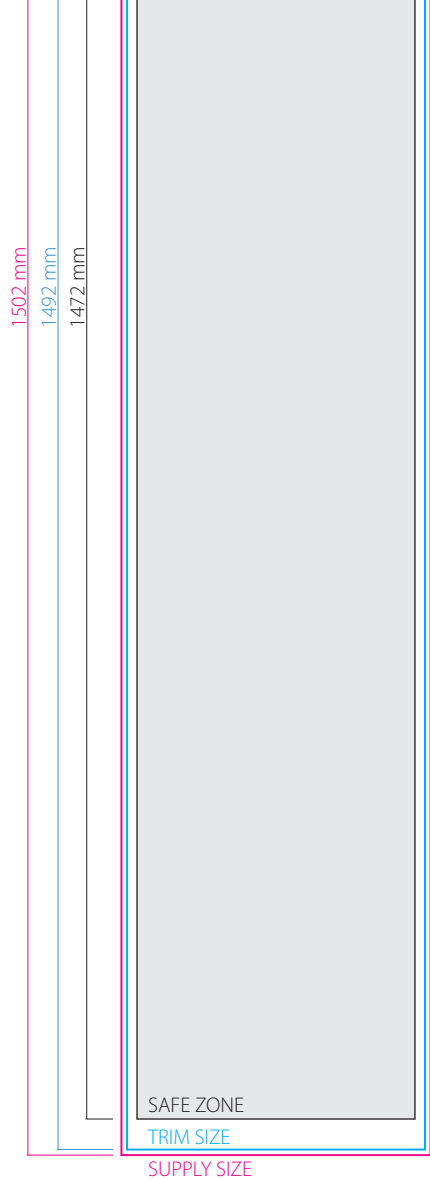
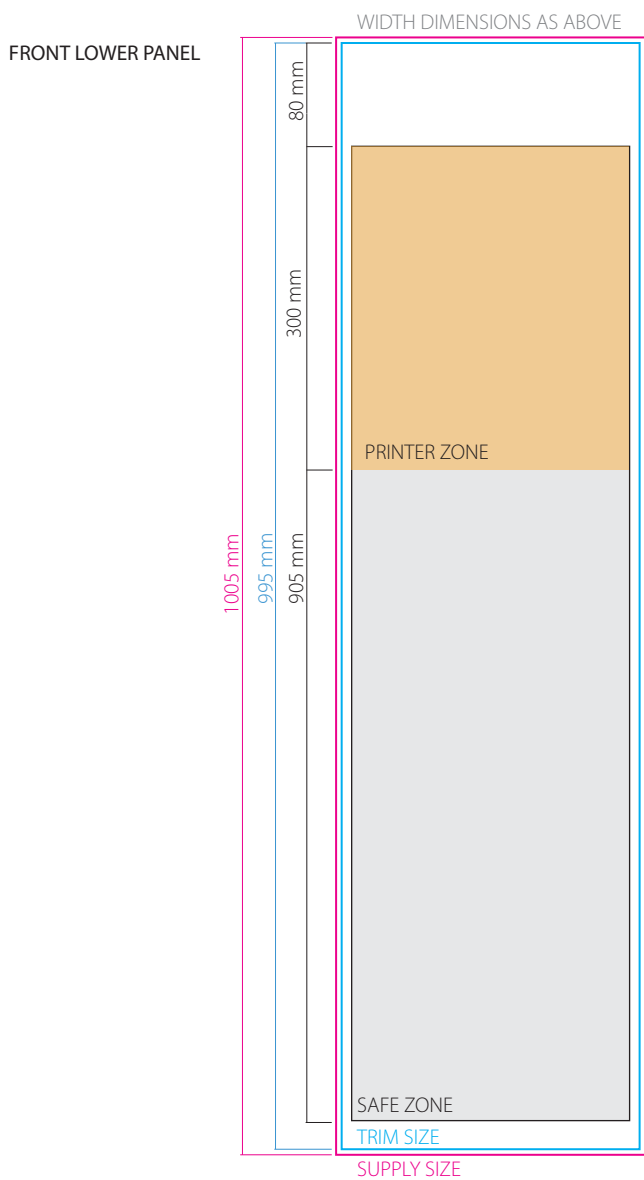
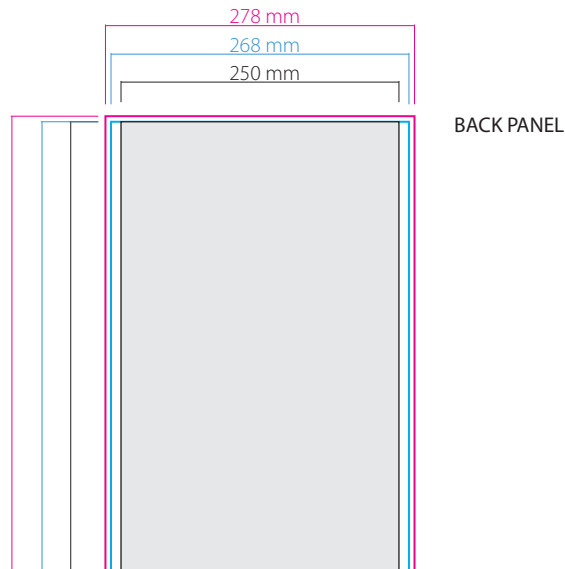
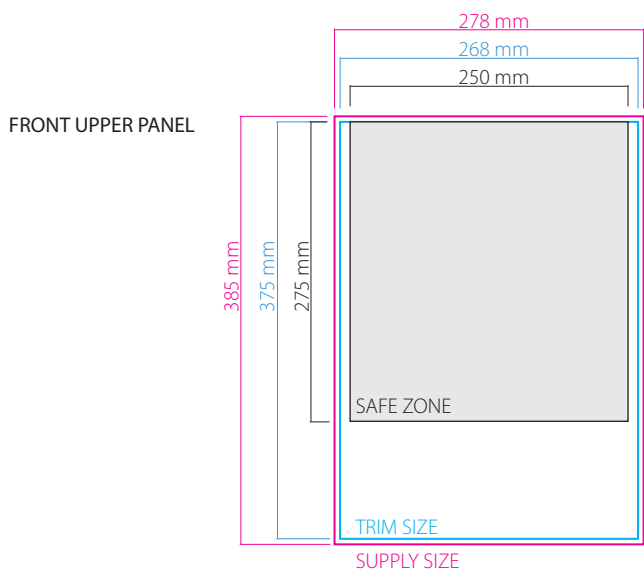

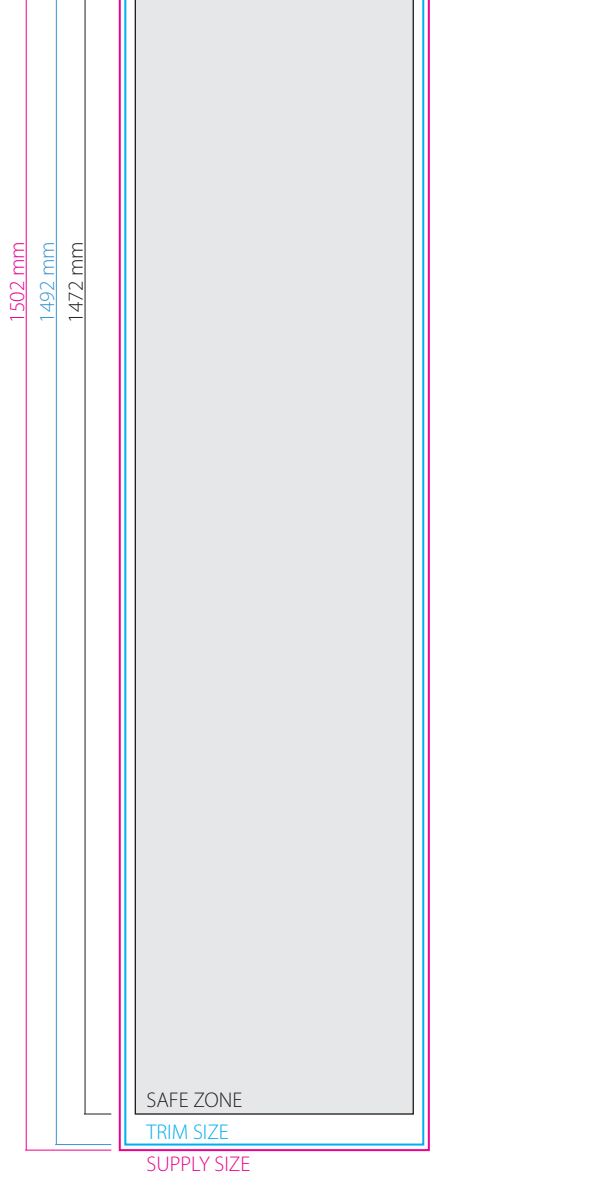
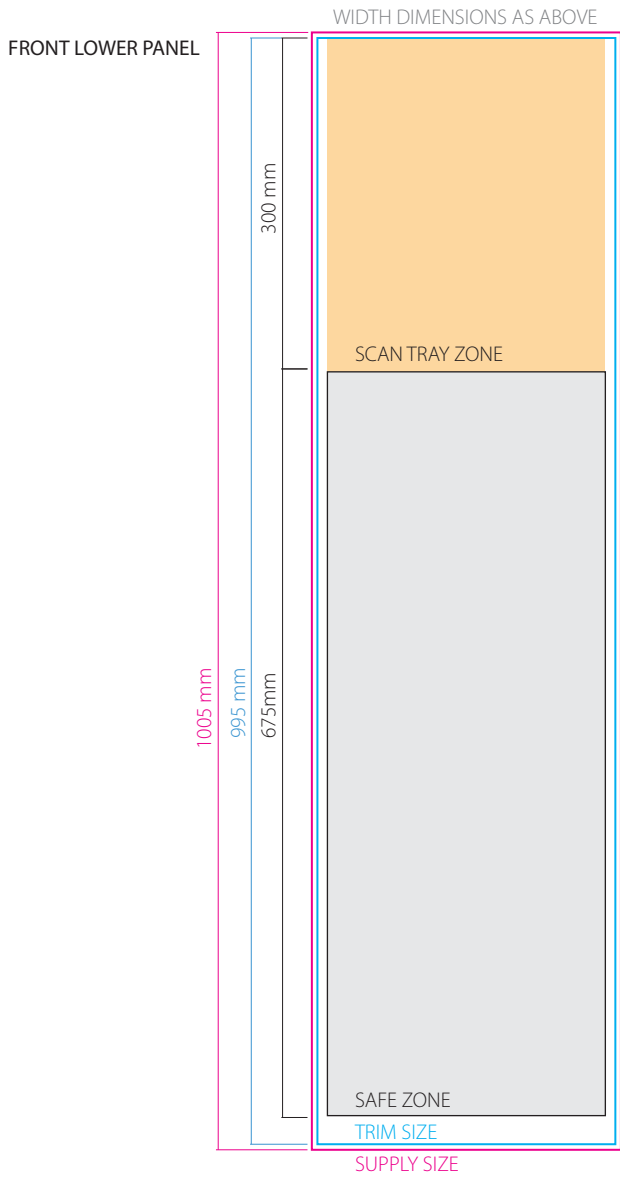
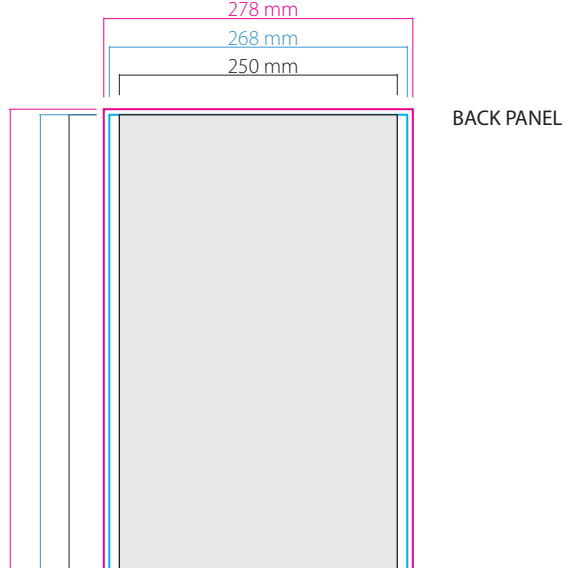
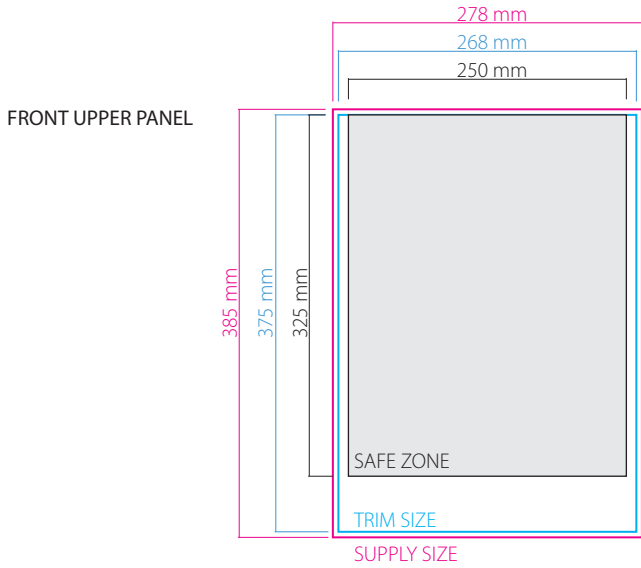

FRONT PANEL

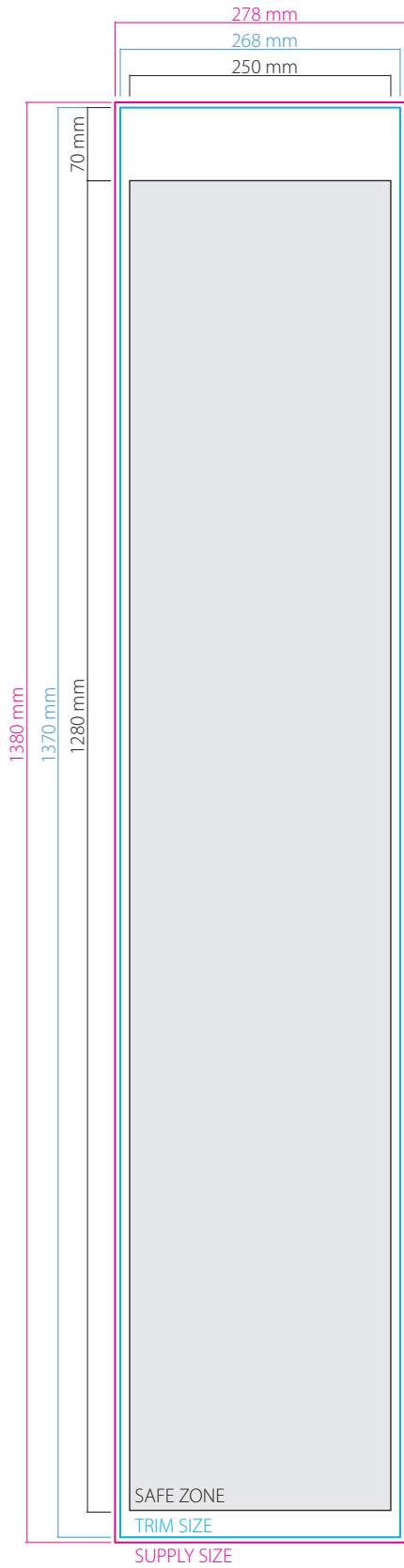

BACK PANEL

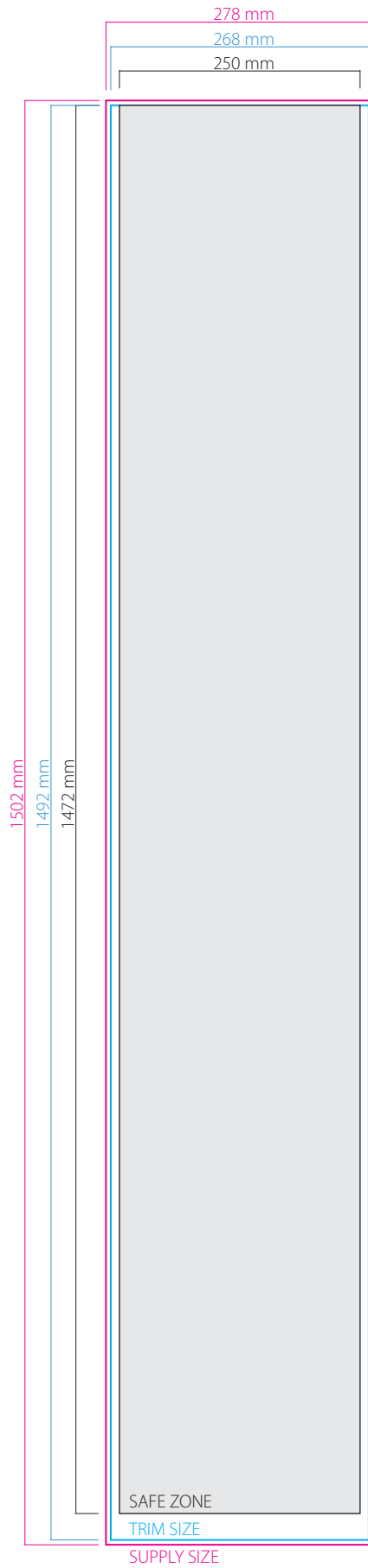

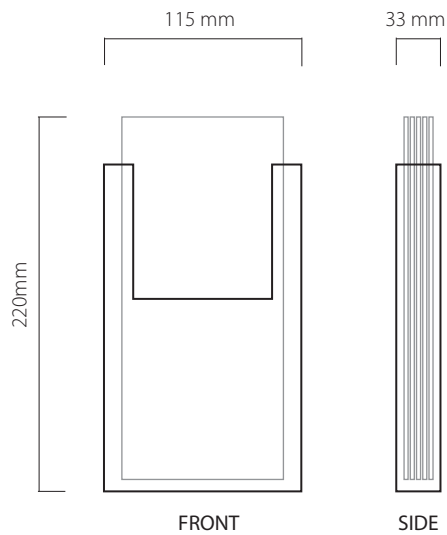

DL BROCHURE HOLDER

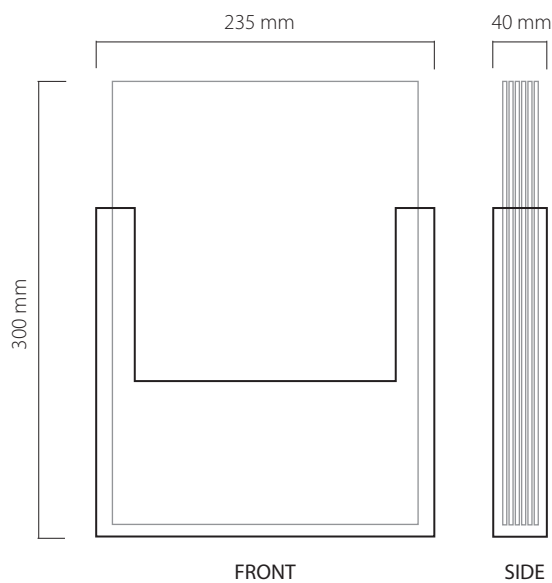

A4 BROCHURE HOLDER

Brochure holders are generally mounted on the X Display Front Lower Panel or Back Panel in you preferred location.

If your order includes a brochure holder option, please use the overall sizes above to help map out your artwork around these elements and dimensionally indicate where you would like them to be mounted in a document that accompanies your final artwork (do not include in your final artwork).

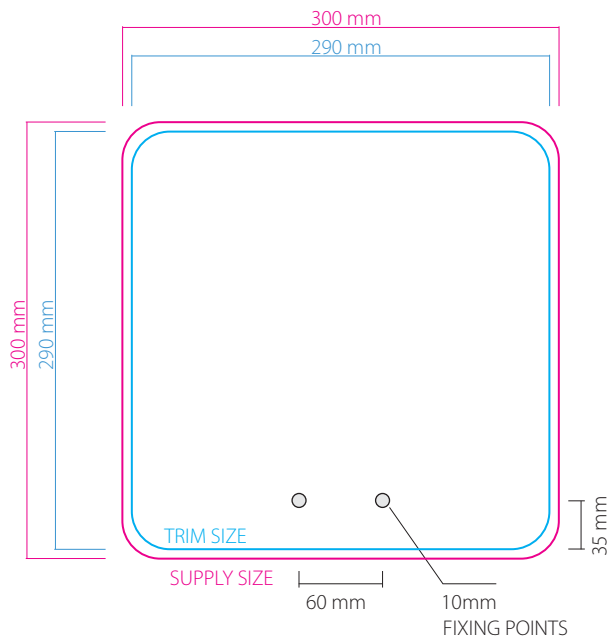

SIGN PANEL

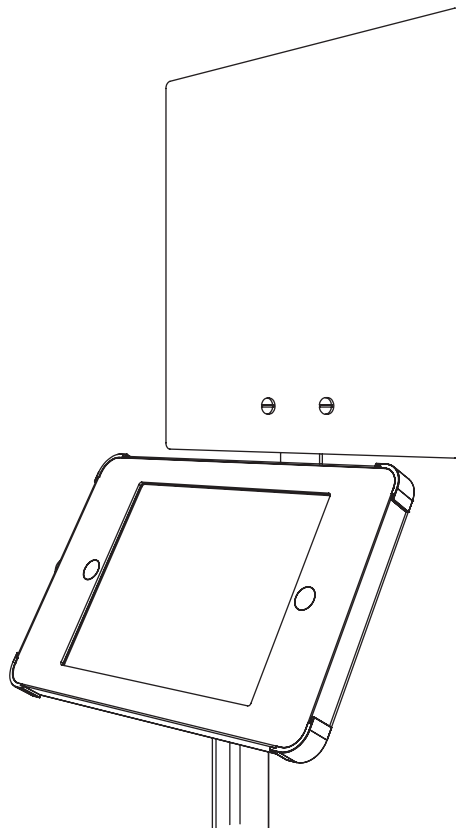

FACEPLATE LOGO PRINTS

CONSIDERATIONS, ORDER + LOGO GUIDELINES

For volume orders (+10 units), we offer an option to have your company logo directly printed onto your X Enclosure Faceplates. Logos can be single or full colour and embossed or etched. If you meet the volume requirements, please refer to the guidelines below to help specify your preferred logo placement and orientation.

1 Considerations:

Some logos with very fine details may not be suitable for our direct application printing process. Therefore we request that only simplified (or hero) version of your company logos are supplied. It should be bold, clear and easy to read with baselines (support text under the main logo) removed.

2 Your choice of faceplate colour (either black or white) should be based on what best compliments your company logo and helps it 'pop'.

3 While the dimensions below act as a good guide, your tablet screen size and orientation can impact on the amount of available space for final logo placement and overall size. In some cases, the Sprocket team may suggest variations to your original requests to ensure the best possible print result. Note logo dimensions below suit max sizes for 10" enclosures.

4 Order + Logo Guidelines

- 1) Logos must be supplied in an EPS (vector) file format. Image files inc jpg + png cannot be used with this printing method.
- 2) If you have specific brand guidelines or spot colour matching requirements, please forward appropriate specifications with your EPS logo file.
- 3) Please select your preferred logo position (A-H below) and include with your email request.
- 4) A PDF proof will be generated on receipt of your logo and placement instructions for approval.
- 5) Written sign off (via reply email) is required before logos can be released for print.

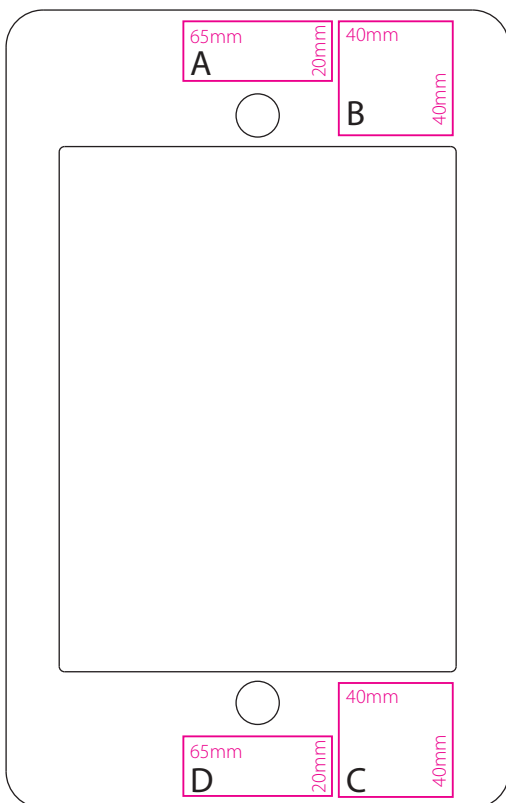

SCREEN ORIENTATION - PORTRAIT

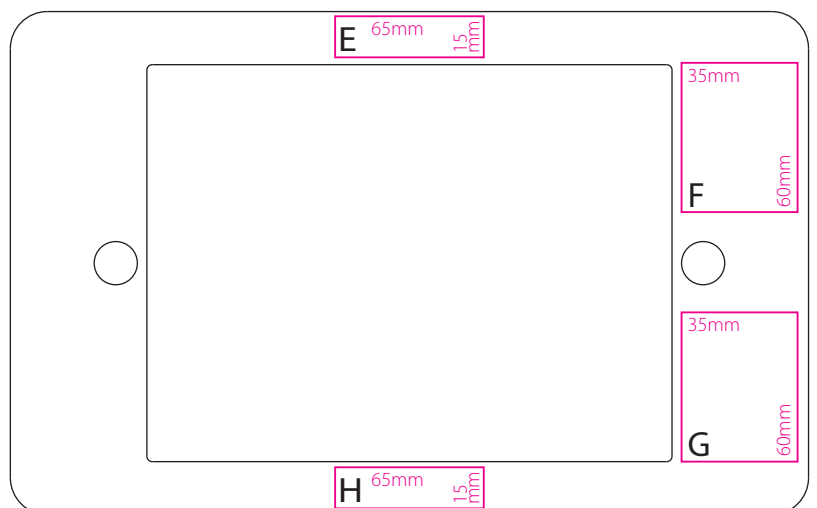

SCREEN ORIENTATION - LANDSCAPE