

## MBus\_DTH\_LCD\_ETH - MBus\_WTH\_LCD\_ETH - MBus\_WTH\_LCD\_ETH\_EXT

The MBus\_xTH\_LCD\_ETH sensors are designed for environment monitoring in industrial, commercial, and residential temperature & humidity applications.

### Features:

- Sensor can be configured using buttons & LCD Display
- High performance digital sensors and circuits to ensure accurate measurement and temperature compensation.
- Good long term stability and reliability
- Fast response
- Multiple output signals selectable: 4-20mA, 0-5V or 0-10V
- RS485 communications port for Modbus-RTU, 19.2/9600 Baud
- Ethernet Port for ModbusTCP communication over IP



MBus\_DTH\_LCD\_ETH

### Relative Humidity:

**Sensor:** capacitance polymer

**Operating Temperature:** 0~50°C

**Operating Humidity Range:** 0~98% RH (Non condensing)

**Output:** 4-20mA, 0-5V or 0-10V, RS485 Modbus-RTU

**Accuracy:** 5% RH (25°C, 20~80% RH)

**Hysteresis:** < ±1% RH

**Response time:** < 10s (25°C, in slow air)

**Drift:** < ±0.5% RH / year

MBus\_WTH\_LCD\_ETH



### Temperature:

**Sensor:** Internal 10K Thermistor

**Operating Temperature Range:** -30~50°C (-22~122°F)

**Output:** 4-20mA, 0-5V or 0-10V, RS 485

**Accuracy:** < ±0.5°C @ 25°C

MBus\_WTH\_LCD\_ETH\_EXT



### General:

#### Power Supply:

- If NOT using 0-10V or 4-20mA output transducers: 12-24VAC/DC +/- 10%
- If using 0-10V or 4-20mA output transducers: 15-24VAC/DC +/-10%

#### Power Consumption:

- **12VDC Power supply:** assume 2 watts per sensor
- **24VAC Power supply:** assume 1VA per sensor

**Current Output Load:** < 500Ω

**Display:** LCD screen for wall / outdoor mount and duct mount

**Display Resolution:** 0.1°C, 0.1% RH

**Operating Temperature:** -30~50°C, 0~98% RH (Non condensing)  
Humidity sensor only accurate from 0~50°C.

**Storage Temperature:** -30~60°C

**Plastic Housing:** Flammability rating UL 94V0 file E194560

**Protection:** IP65

**Enclosure views and Dimensions**

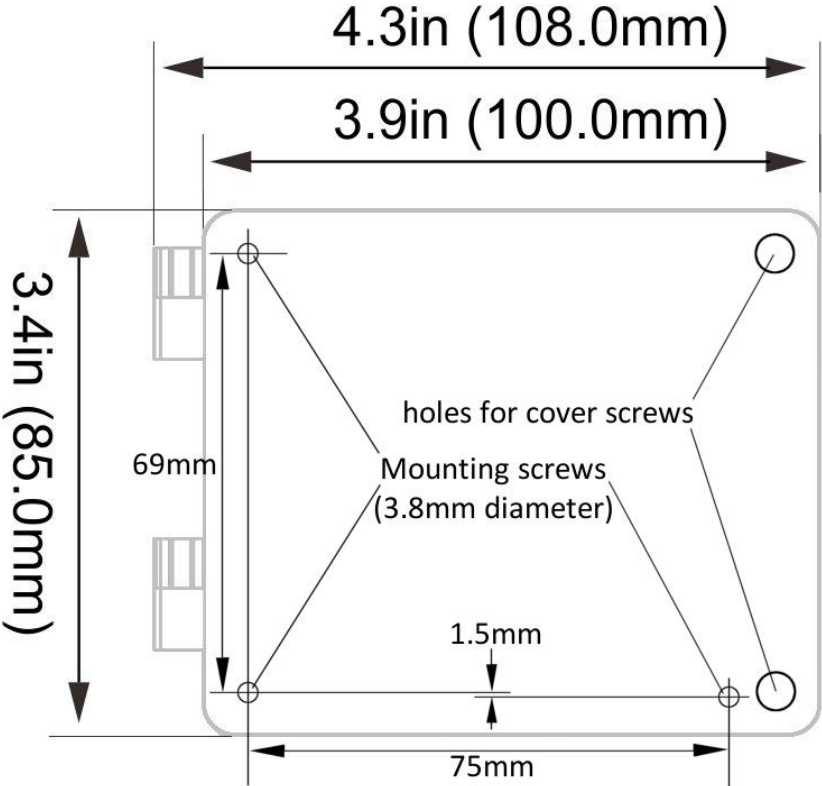

Probe Dimensions (in mm) for MBus\_DTH\_LCD\_ETH and MBus\_WTH\_LCD\_ETH

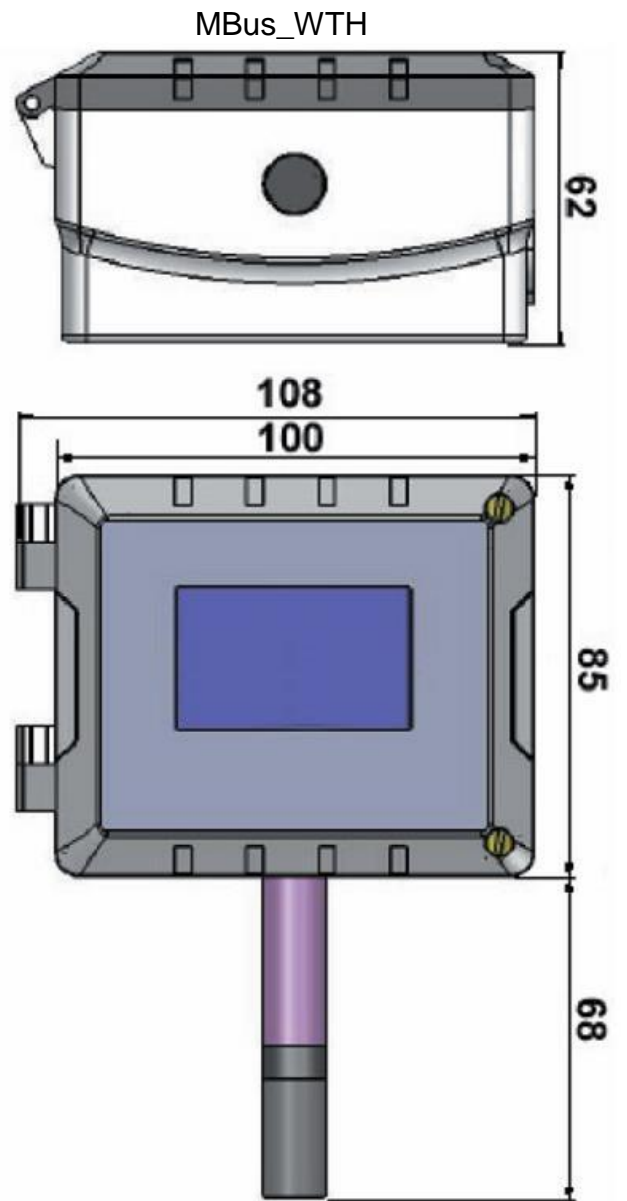
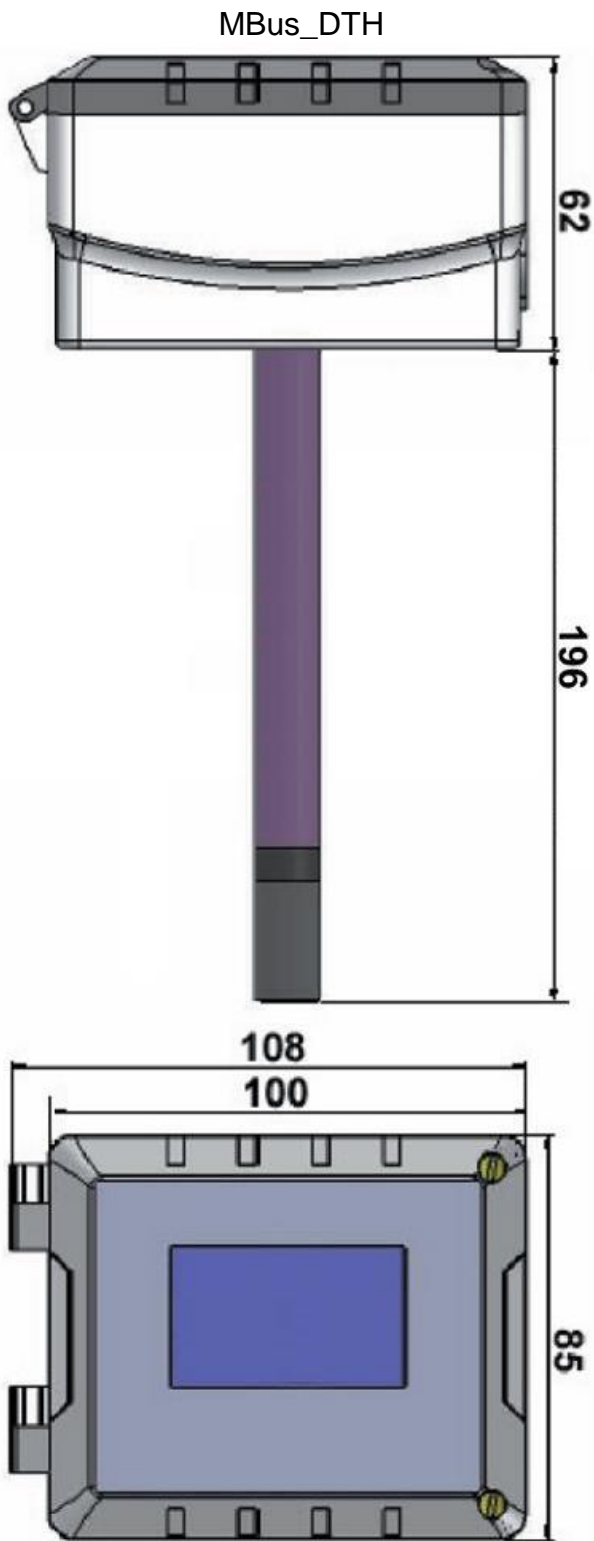

**Probe Dimensions for MBus\_WTH\_LCD\_ETH\_EXT (mm)**

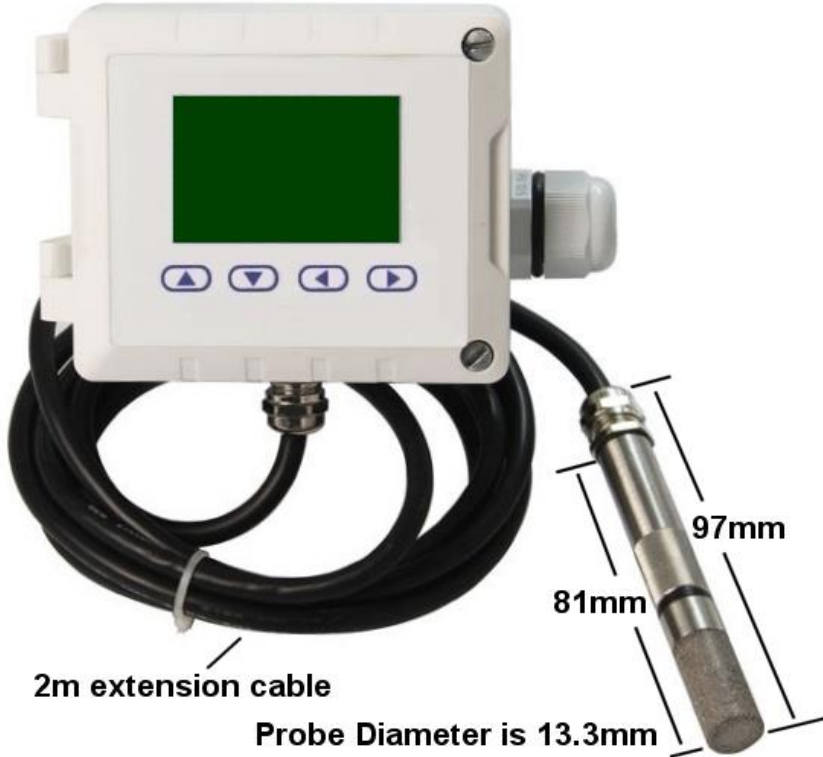

**Opening and mounting enclosure.**

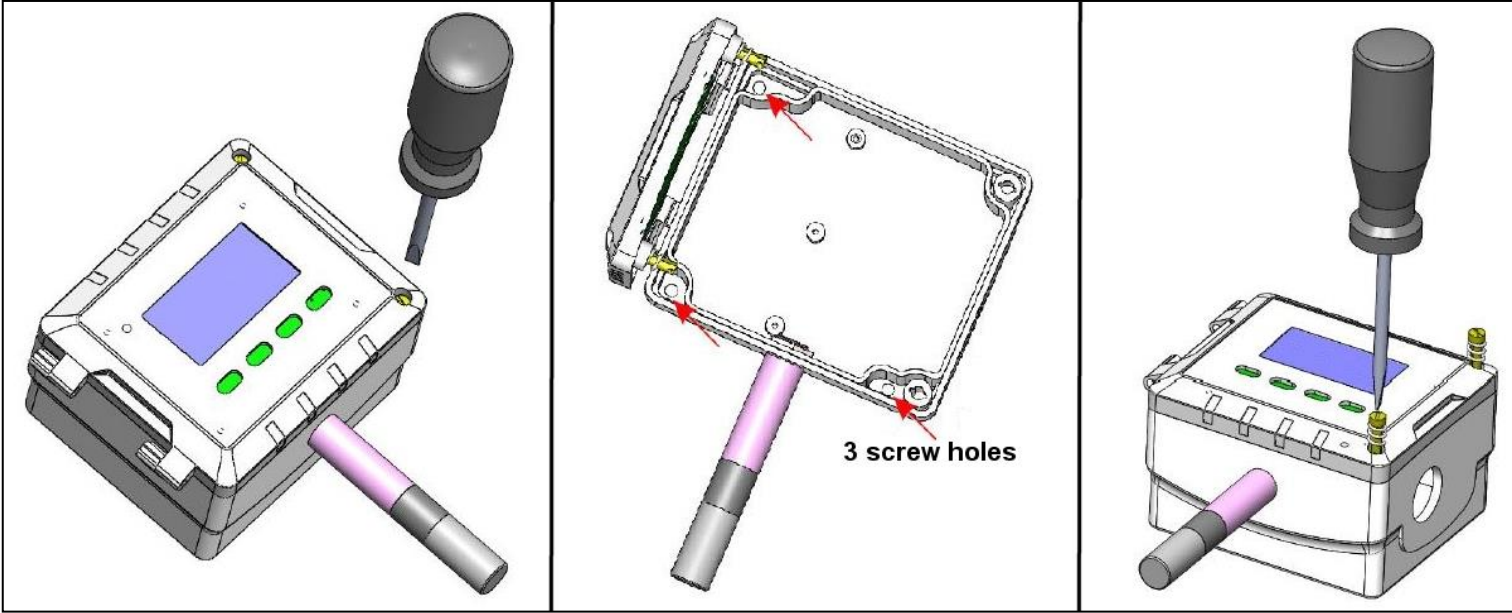

## Inside view & details

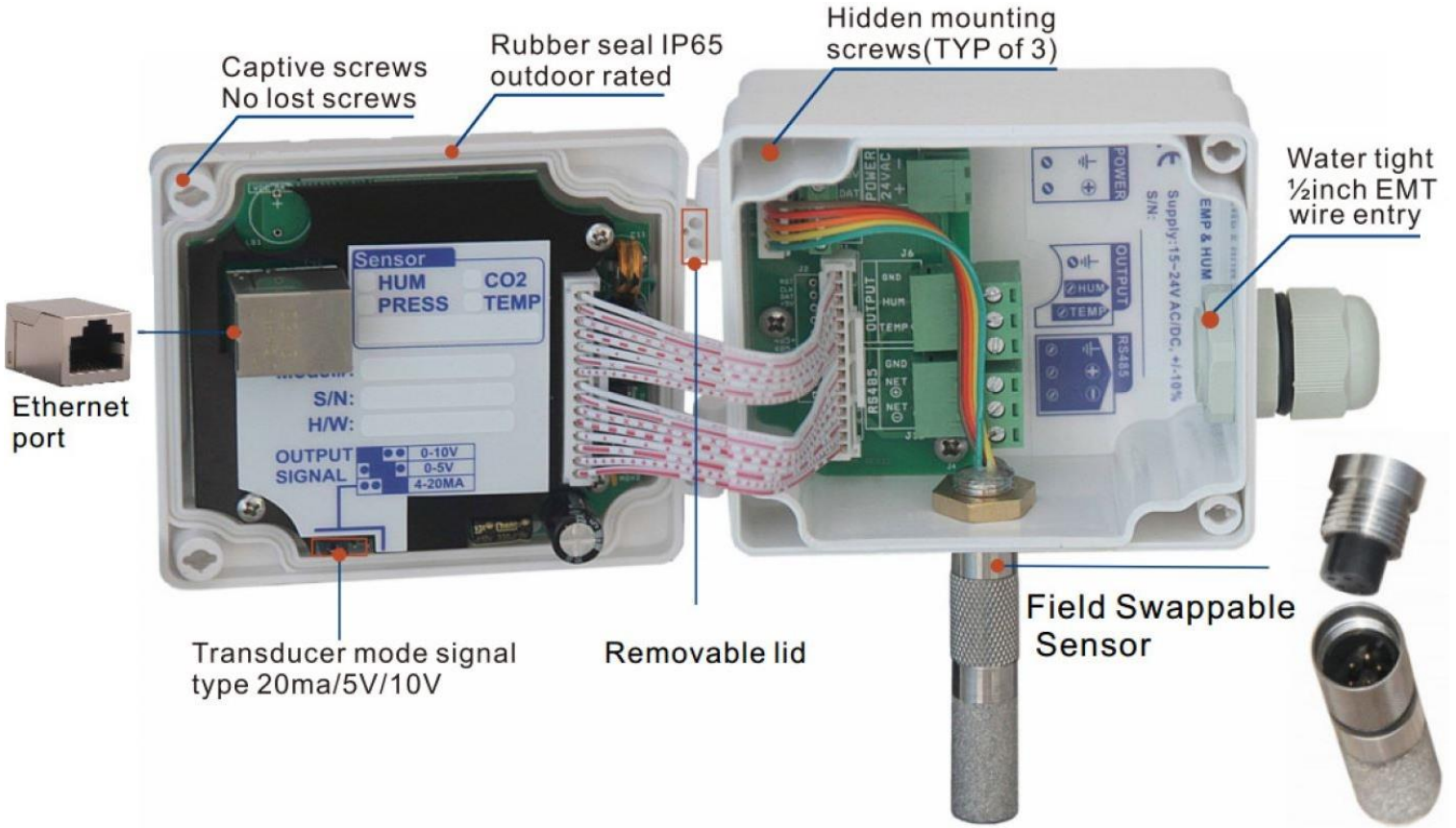

## Wiring Diagram

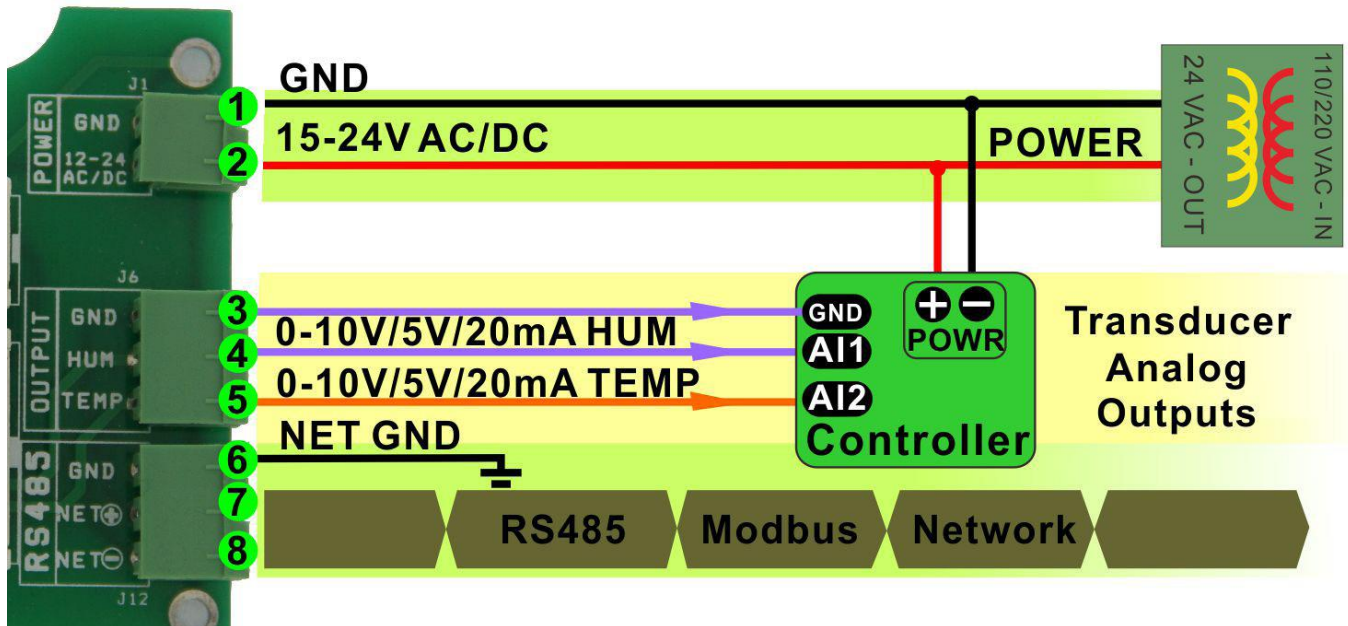

## Modbus Register List

Default Comm Parameters: 19200 baud, 8 data bits, no parity, 1 stop bit

The Modbus Device Address can be read under the "Miscellaneous" menu item in the LCD parameters.

Address	Bytes	Range	Defaults	Register & Description
0-3	4	-	-	Serial Number: Read only
4-5	2	-	-	Software Version: Read only
6	1	0-255	255	Modbus Device Address: You can read/change this under the LCD "Miscellaneous" menu
8	1			Hardware Revision: Read only
15	1	0-4	1	Baudrate: 0=9600baud, 1=19200baud, 2=38400baud, 3=57600baud, 4=115200baud
40-45	6	-	-	MAC Address: Read only
46	1	0-1	0	IP Mode: 0=Static, 1=DHCP
47-48	2	-	-	Upper 2 bytes of IP Address
49-50	2	-	-	Lower 2 bytes of IP Address
51-52	2	-	-	Upper 2 bytes of Subnet mask
53-54	2	-	-	Lower 2 bytes of Subnet mask
55-56	2	-	-	Upper 2 bytes of Gateway IP
57-58	2	-	-	Lower 2 bytes of Gateway IP
60	1	0-255	502	Modbus TCP Port
61-75	15	-	-	UNUSED: Mirrors registers 46-60: used as temp memory when any IP info is changed.
100	2	-	-	<b>Room Temp Reading in DegF.</b> This reg can be written to adjust temp calibration offset.
101	2	-	-	<b>Room Temp Reading in DegC.</b> This reg can be written to adjust temp calibration offset.
121	1	0-1	1	<b>Temperature units for LCD display:</b> 0=DegC, 1=DegF
185	1	0-4	1	Baudrate: same as register 15 above.
186	1	1-3	3	Analog Output jumper setting: 1=0-10V, 2=0-5V, 3=4-20mA (Read Only)
285	2	-	0	Temp AO Low Range (DegC x 10)
286	2	-	1000	Temp AO High Range (DegC x 10)
287	2	-	0	Hum AO Low Range (%RH x 10)
288	2	-	1000	Hum AO High Range (%RH x 10)
304	2	0-1000	-	<b>Humidity Reading in %RH x 10.</b> This reg can be written to adjust hum calibration offset
370	1	0-3	-	Analog Output Auto/Manual Select. Bit0:temp, Bit1:hum. 0=Auto, 1=Manual
371	2	-	-	Temp Analog Output Manual Command (if bit0 set to 1 in Reg370)
372	2	-	-	Humidity Analog Output Manual Command (if bit1 set to 1 in Reg370)
373	2	0-1000	-	Mirrors humidity reading in Reg304 (Read only)
374	2	-	-	Humidity Sensor raw unscaled sampling value (Read only)
381-400	-	-	-	Factory Calibration points for Humidity Sensor (Read only - do not change)
401-410	-	-	-	Temperature AO voltage calibration offsets. (expert only)
411-420	-	-	-	Humidity AO voltage calibration offsets. (expert only)
421-430	-	-	-	Temperature AO Current calibration offsets. (expert only)
431-440	-	-	-	Humidity AO Current calibration offsets. (expert only)
450	-	-	-	Temperature Calibration Offset: In DegC x 10. So -10 Cal offset = Temp change of -1.0C
451	-	-	-	Humidity Calibration Offset: In %RH x 10. So +100 Cal offset = %RH change of 10%RH
454	1	0-1	0	Hum Calibration table select: 0=factory, 1=User (expert only)
455	1	-	-	Number of user Hum calibration points (expert only)
456-475	-	-	-	User Hum Calibration points (expert only)
1239-1242	-	-	-	RTC date parameters - 1239:year, 1240:month, 1241:day, 1242:day of week.
1243-1245	-	-	-	RTC time parameters - 1243:hour, 1244:minute, 1245:second.

For more detailed modbus register information, please email [support@datanab.com](mailto:support@datanab.com)