

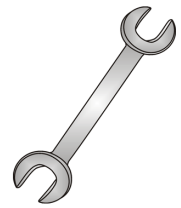

Tow-Trust Towbars

Important: Please read General Notes overleaf before fitting



Issue 3

TVW3 VOLKSWAGEN TIGUAN 2008> AUDI Q3 2011>

Item	Qty	Description	Item	Qty	Description
A	1	Crossmember	E	2	M16 x 50 Bolts Nuts & S/P Washers
B	1	Extension Bar	F	6	M10 x 40 Bolts Grade 10.9 & S/P Washers
C	1	L/H Side Arm	G	1	M12 x 100 Grade 10.9 Bolt & Nyloc Nut
D	1	R/H Side Arm	H	2	M12 x 40 Bolts & S/P Washers
			J	4	10 x 40 Flat Washers
			K	2	10 x 30 Flat Washers
			L	4	12 x 25 Flat Washers

1. Remove the rear bumper, 2 fixings each side on the boot hatch recess, 4 fixings along lower edge, remove the number plate to reveal two fixings through rear panel, 2 fixings securing wheel arch liner, unclip and release the wheel arch edging trim to reveal a push in fixing, unplug the bumper wiring loom from inside the vehicle found in the bottom rear r/h corner and feed through grommet, pull bumper tips outward first to release from vehicle body then rear wards.
2. Cut the bumper around pre marked area.
3. Remove the rear impact beam. **Important** refit bolts only to the rear panel.
4. Using item F with item J bolt the correct arms (see sketch) into each chassis members at the forward most mounting point only.
5. Insert item A into the open ends of the chassis members and in between items C and D and bolt in place through the rear most mounting point on the vehicle with item F and item J.
6. Using item F and item K bolt item A to items C and D.
7. Fully tighten all nuts and bolts and ensure towbar is rigid and secure.
8. At this stage we recommend you install your Towbar wiring harness as it may become difficult once bumper is reinstalled.
9. Refit the rear bumper and reconnect bumper wiring loom.
10. Using item G with item L and item H with item L bolt item B to item A.
11. Using item E bolt the ball bracket and wiring plate (not supplied in this kit) to item B.

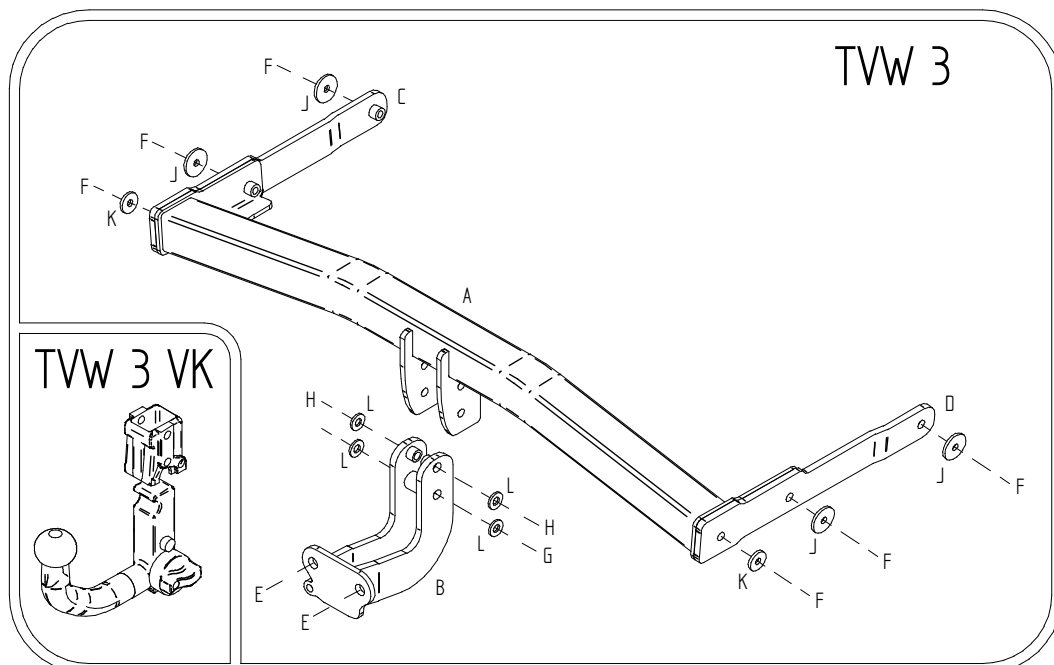

Note: nose load limits and vehicle manufacturer's trailer / caravan weight limits must be observed.