

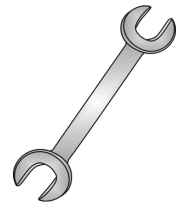

Tow-Trust Towbars

Important: Please read General Notes overleaf before fitting



Issue 4

TVW14 MAN TGE / VOLKSWAGEN CRAFTER CHASSIS CAB SRW & DRW 2017>

Item	Qty	Description	Item	Qty	Description
A	1	TVW14 Crossmember	C	2	M16 x 50 Bolts & Flange Lock Nuts
B	2	Side Arms	D	8	M12 x 120 Bolts & Nyloc Nuts
			E	4	M14 x 40 Bolts & Nyloc Nuts
			F	16	12 x 25 Flat Washers
			G	8	14 x 27 Flat Washers
			H	2	Spacer Plates
			J	4	M10 x 40 Bolts & S/P Washers
			K	4	10 x 25 Flat Washers

1. Remove the Spare wheel mechanism from the O/S. four fixings located through the light board. (Towbar can be fitted without removing this item).
2. **Vehicles Fitted With Black Under Run Beam:** Remove rear beam, discard side arms and retain angle brackets and M10 fixings (Item X).
3. Using Item D with Item F fix Items B to the inside face of each chassis member.
4. Using Item E with Item G fix Item A to Items B.
5. **Vehicles Fitted With Black Under Run Beam:** Refit beam to Item A with Items X.
6. Using Item C fix you desired ball bracket and wiring plate (Not supplied in this kit) to Item A.
7. **Vehicles Fitted With Black Under Run Beam:** You will require a 4 bolt Towball with 56mm x 83mm (M10) hole centres to fit directly to the beams hole pattern, alternatively open holes out in the beam only with a cone cutter to take a standard 2 bolt Towball 90mm (M16) hole centres for vehicles up to 3500Kg GVM or a standard 4 bolt Towball 85mm x 44mm (M12) hole centres for vehicles over 3500Kg GVM.
8. Fully tighten all fixings ensuring the Towbar is rigid, square and secure.
9. Refit spare wheel mechanism.

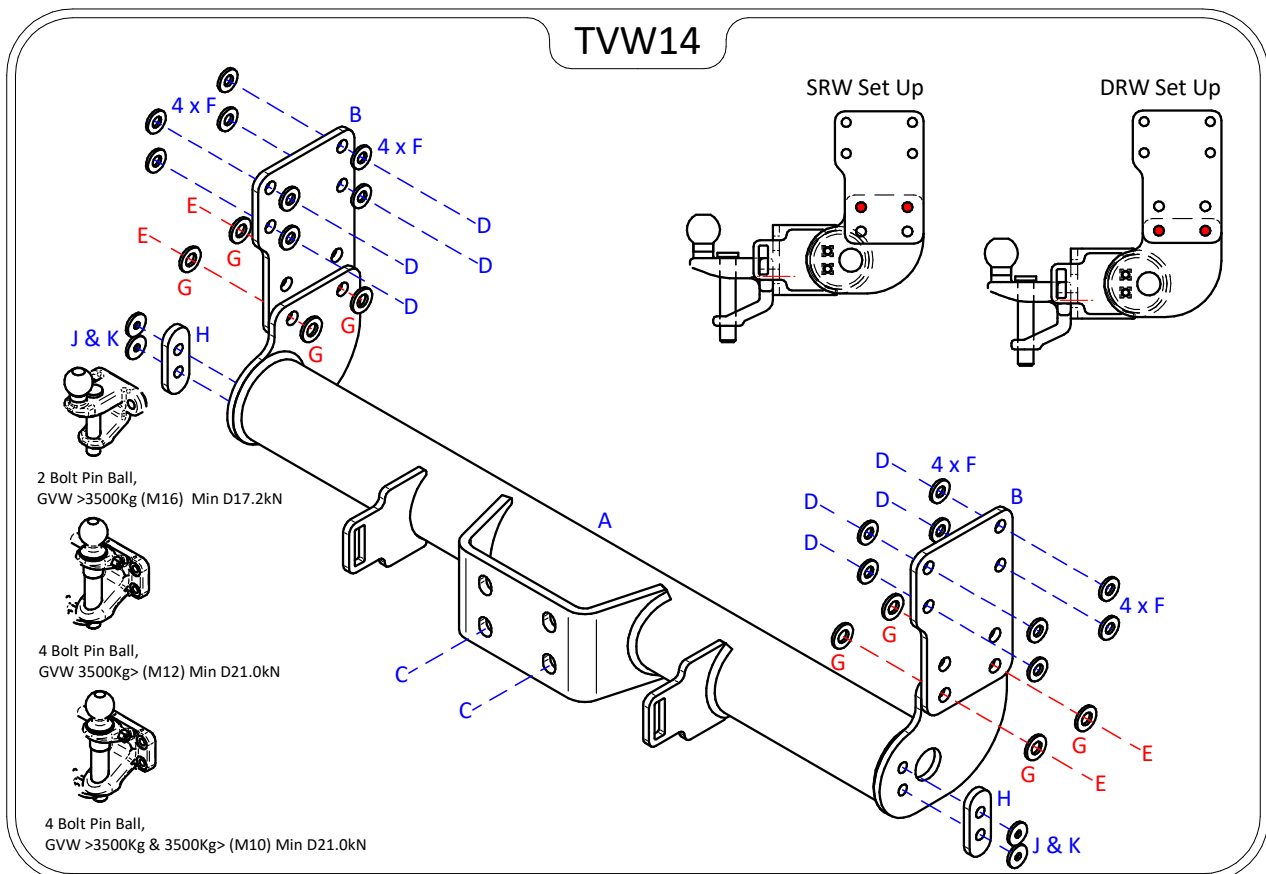

Note:

1. Recommended Torque Setting for M12 Grade 10.9 -130 Nm. (For other Torque Settings see notes overleaf.)
2. Nose load limits and vehicle manufacturers trailer / caravan weight limits must be observed.