

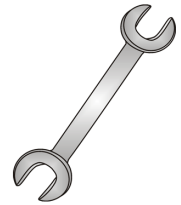

# Tow-Trust Towbars

Important: Please read General Notes overleaf before fitting



Issue 2

## TVW1 Volkswagen Fox 2005>

Item	Qty	Description	Item	Qty	Description
A	1	Crossmember	D	2	M16 x 40 Bolts, Nuts & S/P Washers
B	2	Side Arms	E	2	M12 x 85 Grade 10.9 Bolts & Nyloc Nuts
C	1	Extension Bar	F	8	M10 x 35 Grade 10.9 Bolts, 2 Nuts & 8 S/P Washers
			G	4	12 x 25 Flat Washers
			H	4	10 x 40 Flat Washers
			J	1	Socket Plate

1. Remove rear bumper. Three fixings along the bottom edge, three fixings around each wheel arch, two tip fixings. Fold back the lining on the rear panel to reveal one fixing each side.
2. Temporarily disconnect the number plate light.
3. Remove the inner bumper beam. (This is not refitted with the towbar)
4. Cut a section from the lower edge of the bumper, centrally 65mm wide x 105mm deep.
5. Loosen the bolts securing the cooling filter on the right hand side.
6. Remove the tape from the outer face of each chassis covering the towbar mounting point holes.
7. Locate Item B into each chassis and using Item F with Item H loosely bolt into place.
8. Using Item F bolt Item A to Item B.
9. Fully tighten all nuts and bolts and ensure the towbar is rigid and secure.
10. Tighten cooling filter and refit the rear bumper and number plate light.
11. Using Item E with Item G bolt Item C and Item J to Item A.
12. Using Item D bolt the ball bracket and wiring plate (not supplied in this kit) to the mounting plate.

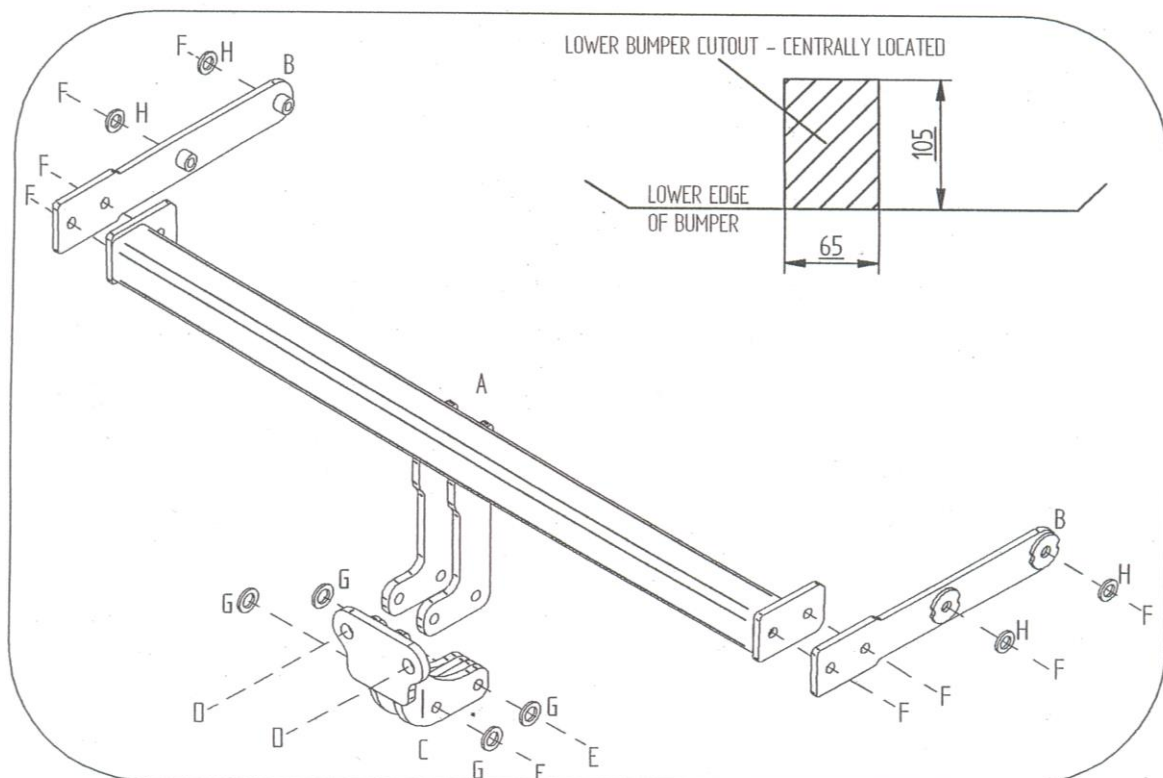

**Note:**

1. Recommended Torque Setting for M12 Grade 10.9 -139 Nm. (For other Torque Settings see notes overleaf.)
2. Nose load limits and vehicle manufacturers trailer / caravan weight limits must be observed.