

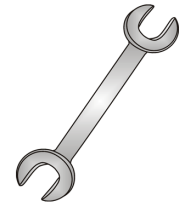

Tow-Trust Towbars

Important: Please read General Notes overleaf before fitting



Issue 7

TP8VK PEUGEOT 3008 CROSSOVER 2009>

Item	Qty	Description	Item	Qty	Description
A	1	Crossmember	D	2	M12 x 25 Bolts & S/P Washers
B	1	Detachable Housing	E	4	M10 Nyloc Nuts
C	2	Handed Side Arms	F	4	M8 x 45 Bolts Grade 10.9, 5 Nut & 4 S/P Washers
			G	4	M12 x 35 Bolts, Nuts & S/P Washers
			H	2	M12 x 22 Bolts & S/P Washers
			J	4	10 x 40 Flat Washers
			K	16	8 x 25 Flat Washers
			L	6	12 x 25 Flat Washers
			M	1	Flip Up Socket Plate
			N	2	8mm Exhaust Spacer Plates
			P	2	8mm Insert Nuts

1. Remove the three fixings from the lower edge of the rear bumper.
2. Remove the lashing eyelets from the bottom face of each chassis and discard.
3. Remove the three M8 fixings through the back panel connecting rear crash beam and back panel and discard.
4. Refit items F through the back panel using items K under the bolt heads and on the near side using the nut provided to secure item F. (Advise that these are fully tightened at this stage)
5. Slide items C onto fixing F and up onto the studs on the lower face of chassis members and fix in place with items E and J and the nuts provided in item F.
6. Using item G fit item A between items C.
7. Using item H and item L and item D with item L bolt item B and item M to item A.
8. Fully tighten all nuts and bolts ensuring Towbar is rigid and secure.
9. **NOTE: YOU MAY FIND IT NECESSARY TO LOWER THE EXHAUST ON SOME MODELS USING ITEMS L,N,P.**

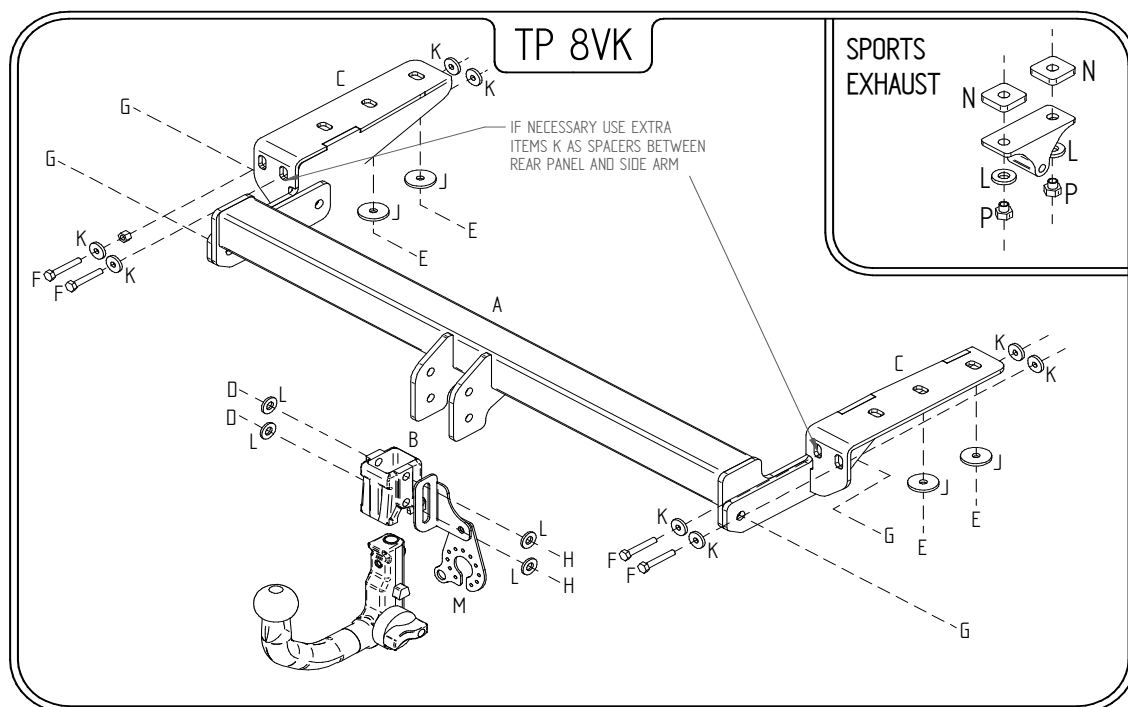

Note:

1. Recommended Torque Setting for M12 Grade 10.9 -139 Nm. (For other Torque Settings see notes overleaf.)
2. Nose load limits and vehicle manufacturer's trailer / caravan weight limits must be observed.