

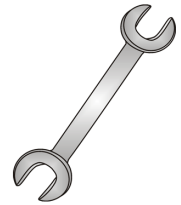

Tow-Trust Towbars

Important: Please read General Notes overleaf before fitting



Issue 3

TP427 Peugeot Boxer/Citroen Relay/Fiat Ducato Vans 1994 - 2006

Item	Qty	Description	Item	Qty	Description
A	1	Towbar	D	2	M16 x 50 Bolts, Nuts & S/P Washers
B	2	Clamp Plates	E	2	M14 x 150 x 1.5 Bolts & S/P Washers
C	2	25mm x 109mm Spacer Bushes	F	2	14mm Flat Washers

1. Locate the two rear spring hanger bolts each side, (these correspond with the holes in the towbar) remove these bolts and retain them. NOTE: Do not remove or loosen the remaining spring mounted bolts at this stage.
2. Using the original bolts loosely bolt item A into position.
3. Locate the remaining spring hanger bolts (one each side, these line up with the large holes in the tow bar) remove these bolts, they are no longer required.
4. Place item C through the large hole in the towbar using item B, with item E and item F bolt the towbar into position.
5. Using item D bolt the ball bracket and wiring plate (not supplied in this kit) to the mounting plate.
6. Fully tighten all nuts and bolts and ensure the towbar is rigid and secure.

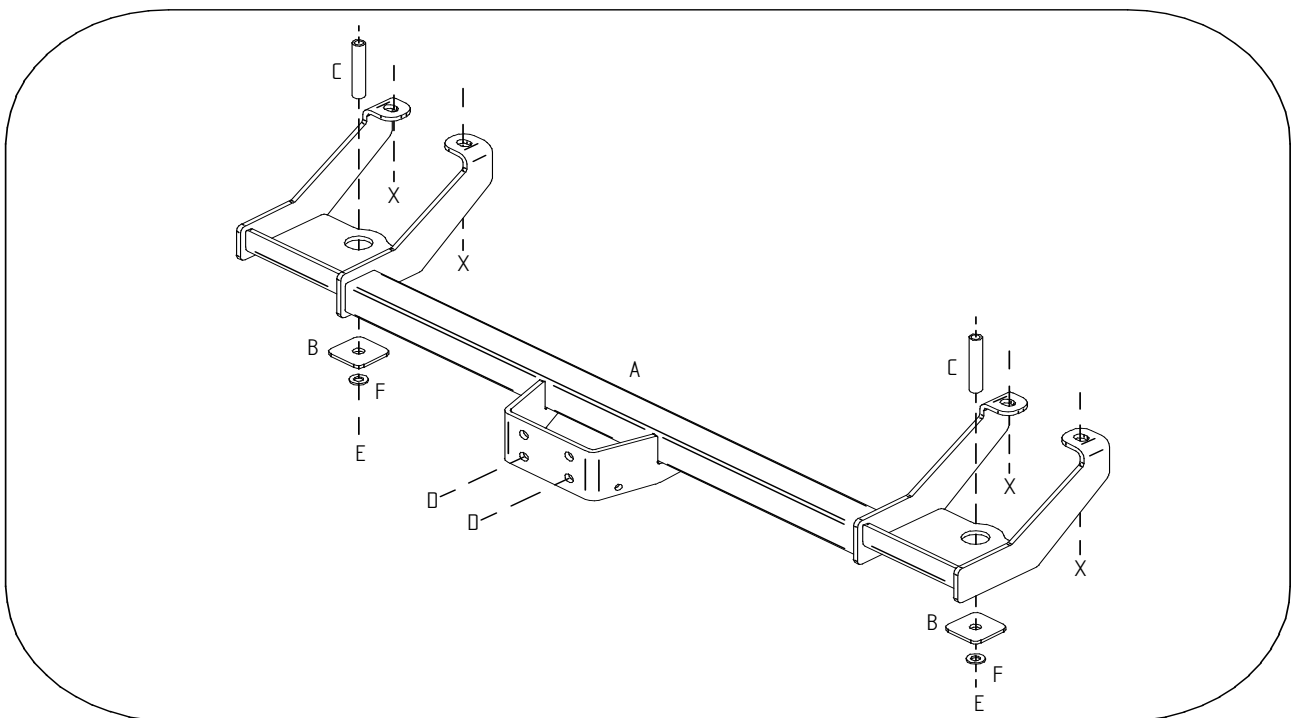

Note:

1. Recommended Torque Setting for M12 Grade 10.9 -139 Nm. (For other Torque Settings see notes overleaf.)
2. Nose load limits and vehicle manufacturers trailer / caravan weight limits must be observe