

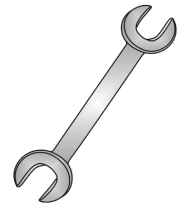

# Tow-Trust Towbars

Important: Please read General Notes overleaf before fitting



Issue 3

## TM869 Mercedes V Class Vito & Viano 1996-2003

Item	Qty	Description	Item	Qty	Description
A	1	Towbar	D	2	M16 x 50 Bolts, nuts & S/P washers
B	2	Straps	E	6	M12 x 100 Bolts, nuts & S/P washers
C	6	25 x 58 Spacer Tubes	F	8	M8 x 30 Bolts-4 nuts & 8 S/P washers
			G	12	8 x 25 Flat Washers
			H	6	12 x 40 Flat Washers
			J	4	M8 Special Insert Nuts

1. Remove the bumper (8 nuts across the top edge & two plastic rivets from the bumper tips).
2. Remove the spare wheel and the plastic insert from the bumper. (This will not be re-fitted).
3. Using item E with item H and item C, loosely bolt item A to the existing holes in each chassis member. (Item C will protrude outside the chassis member).
4. Locate item J into the existing holes in the crossmember. Using item F with item G loosely bolt item B to item A and item B to the special nuts in the crossmember.
5. Using item D bolt the ball bracket and wiring plate (not supplied in this kit) to the mounting plate.
6. Fully tighten all nuts and bolts and ensure the towbar is rigid and secure.
7. Replace the rear bumper and spare wheel.

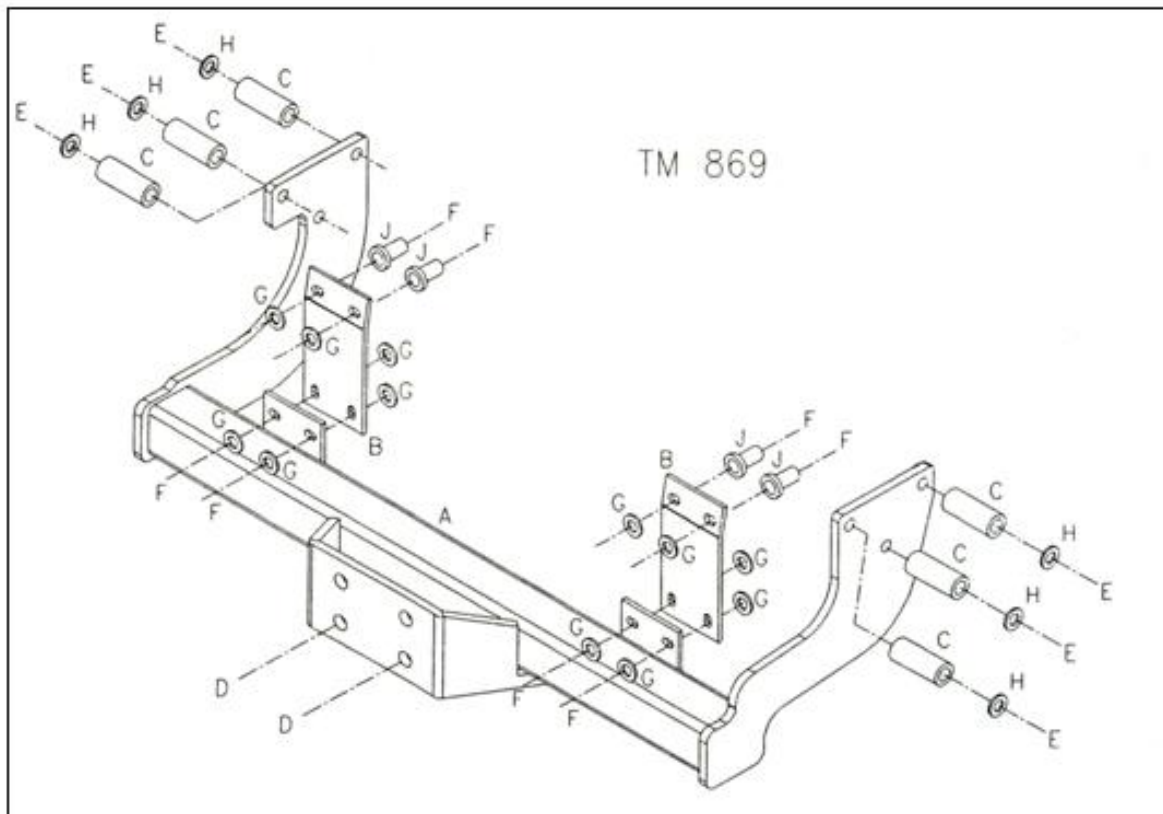

**Note:** nose load limits and vehicle manufactures trailer / caravan weight limits must be observed.