

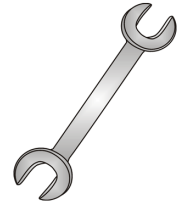

Tow-Trust Towbars

Important: Please read General Notes overleaf before fitting



Issue 5

THY7A Hyundai Santa Fe 2006> KIA Sorento III 2009>

Item	Qty	Description	Item	Qty	Description
A	1	Crossmember	H	2	M16 x 50 Bolts Nuts & S/P Washers
B	1	R/H Side Arm	J	2	M12 x 85 Grade 10.9 Bolts & Nyloc Nuts
C	1	L/H Side Arm	K	4	M10 x 35 x 1.25 Bolts & S/P Washers
D	2	Clamp Plates	L	4	M12 x 120 Bolts & Nyloc Nuts
G	1	Extension Bar	M	4	M14 x 30 Bolts & S/P Washers
			N	4	10 X 40 Flat Washers
			P	8	12 x 25 Flat Washers
			S	4	14 x 27 Flat Washers
			T	1	Socket Plate

1. Lower spare wheel.
2. Remove rear exhausts and heat shields.
3. Remove fog light wiring from bumper crash beam.
4. Locate the four connecting plates on the crash beam and carefully cut out (See sketch) to allow space for the towbar.
5. Using Item L with Item P loosely bolt Item B and Item C to the existing holes in the side of each chassis member with the clamp plate (Item D) on the outer face.
6. Using Item K with item N loosely bolt Item B and Item C to the lower face of each chassis member.
7. Locate Item A into the crash beam and using Item M with Item S bolt to Item B and Item C.
8. Fully tighten all nuts and bolts and ensure the towbar is rigid and secure.
9. Trim heat shields to fit around the towbar side arms and re-fit.
10. Re-fit exhausts, Note if required replace exhaust gaskets at this stage.
11. Replace spare wheel.
12. Using Item J with Item P bolt Item G and Item T to Item A.
13. Using Item H bolt the ball bracket (Not supplied in this kit) to the mounting plate.

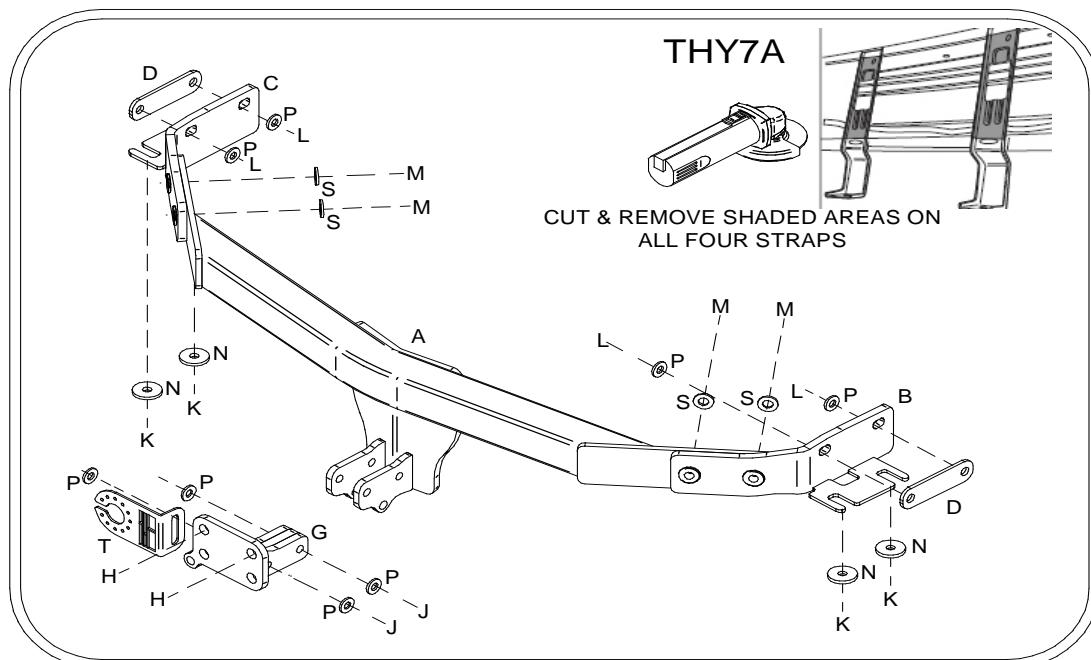

Note:

1. Recommended Torque Setting for M12 Grade 10.9 -139 Nm. (For other Torque Settings see notes overleaf.)
2. Nose load limits and vehicle manufacturer's trailer / caravan weight limits must be observed.