

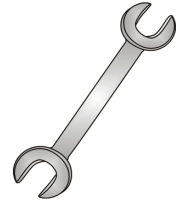

Tow-Trust Towbars

Important: Please read General Notes overleaf before fitting



Issue 1

TFi1SN FIAT DOBLO 2010> & VAUXHALL COMBO 2012>

Item	Qty	Description	Item	Qty	Description
A	1	Crossmember	D	2	M12 x 110 Grade 10.9 Bolts & Nyloc Nuts
B	2	Handed Side Arms	E	6	M10 x 35 x 1.25 Bolts & S/P Washers
C	1	ACS7 / 9207 Swan Neck	F	6	M10 x 35 Bolts, 2 Nuts & 6 S/P Washers
			G	2	15mm Spacer Plates
			H	2	10 x 40 Flat Washers
			J	10	10 x 25 Flat Washers
			K	4	12 x 25 Flat Washers
			L	1	VASP8 L/H Socket Plate

BUMPER REMOVAL:

1. Remove rear light clusters, three fixings each side. This will reveal one fixing under each light locate and remove. Remove two fixings in each wheel arch and one tip fixing each side, four fixings along top edge and three – five fixings along lower edge, pull tips outward to release clips then rearward. Disconnect any necessary wiring looms.
2. Remove the rear crash beam. (This is NOT refitted with the Towbar assembly).

TOWBAR INSTALLATION:

1. Locate all Towbar mounting points and ensure that they are clean and free from any under seal. Remove the bungs from the lower face of each chassis to reveal vertical mounting points.
2. Insert Items B into each correct chassis member and loosely fix in place using Item F and Item H.
3. Using Item E (fine pitch bolts) with item J fix item A to the rear panel ensuring Items B pass through Item A.
4. Using Item F with Item J fix Items B to Item A.
5. Using Item D with Item K and Item G fix Item C and Item L to Item A.
6. Fully tighten all fixings ensuring Towbar is rigid square and secure. It is advisable to seal the open ends of the chassis with an appropriate sealant.
7. Refit the rear bumper and lights. (If necessary cut central tab away).

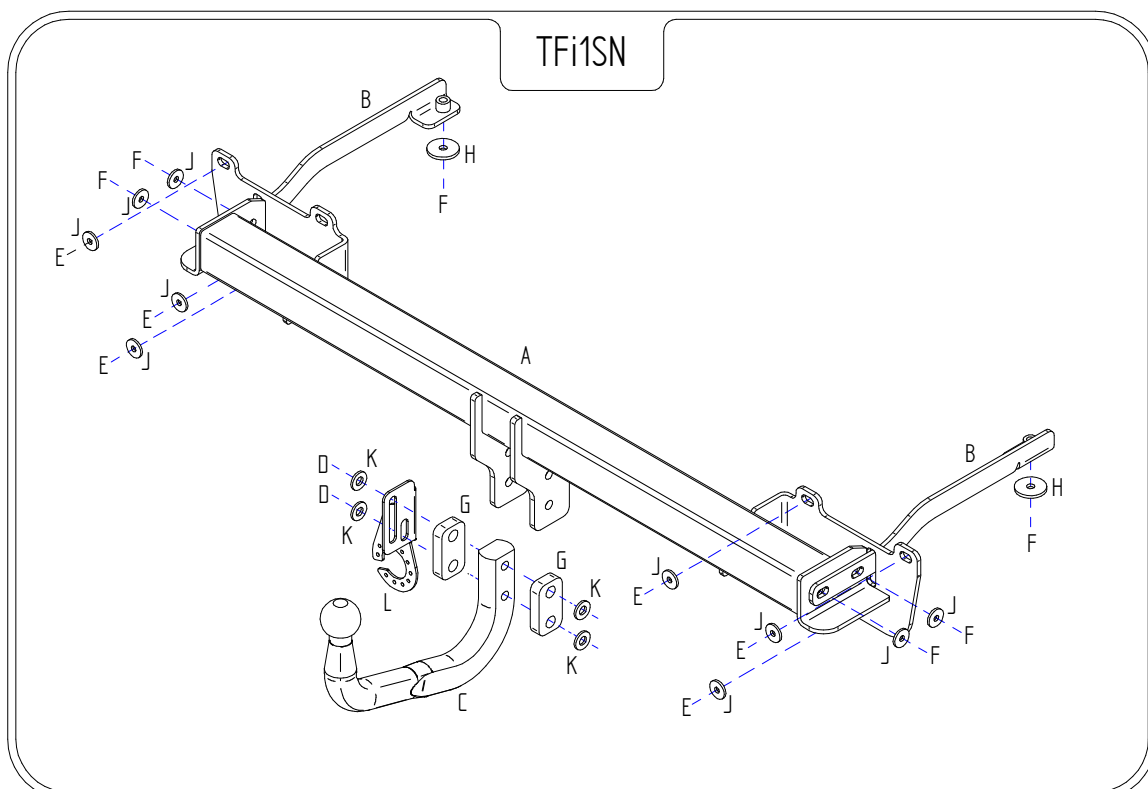

Note:

1. Recommended Torque Setting for M12 Grade 10.9 -139 Nm. (For other Torque Settings see notes overleaf.)
2. Nose load limits and vehicle manufacturers trailer / caravan weight limits must be observed.