

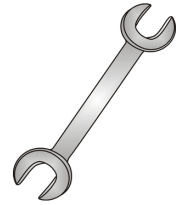

Tow-Trust Towbars

Important: Please read General Notes overleaf before fitting



Issue 1

TFD7SN FORD TRANSIT CONNECT & TOURNEO CONNECT 2014>

Item	Qty	Description	Item	Qty	Description
A	1	Crossmember	D	2	15mm Spacer Plates
B	2	Handed Side Arms	E	6	M10 x 40 Bolts & S/P Washers
C	1	ACS1 / 9201 Swan Neck	F	8	M8 Nyloc Nuts
			G	2	M12 x 110 Grade 10.9 Bolts & Nyloc Nuts
			H	2	10 x 30 Flat Washers
			J	4	10 x 25 Flat Washers
			K	8	8 x 25 Flat Washers
			L	4	12 x 25 Flat Washers
			N	1	VASP8 L/H Socket Plate

BUMPER REMOVAL:

1. Open the rear doors to reveal 7 fixings along the top edge of the bumper and remove, Unclip the bumper starting at the wheel arch tips and pull rearward.
2. Remove the rear crash beam. (This is not refitted with the Towbar assembly, hand back to customer).

TOWBAR INSTALLATION:

1. Using Item F and Item K fix Item A to the rear panel.
2. Insert Items B into each correct chassis member and fix to the vertical chassis point with Item E and Item H.
3. Using Item E and Item J fix Items B to Item A.
4. Using Item G with Item L fix Item C and Item N to Item A using Item D as spacers.
5. Fully tighten all fixings ensuring the Towbar is rigid, square and secure.
6. Refit the rear bumper.

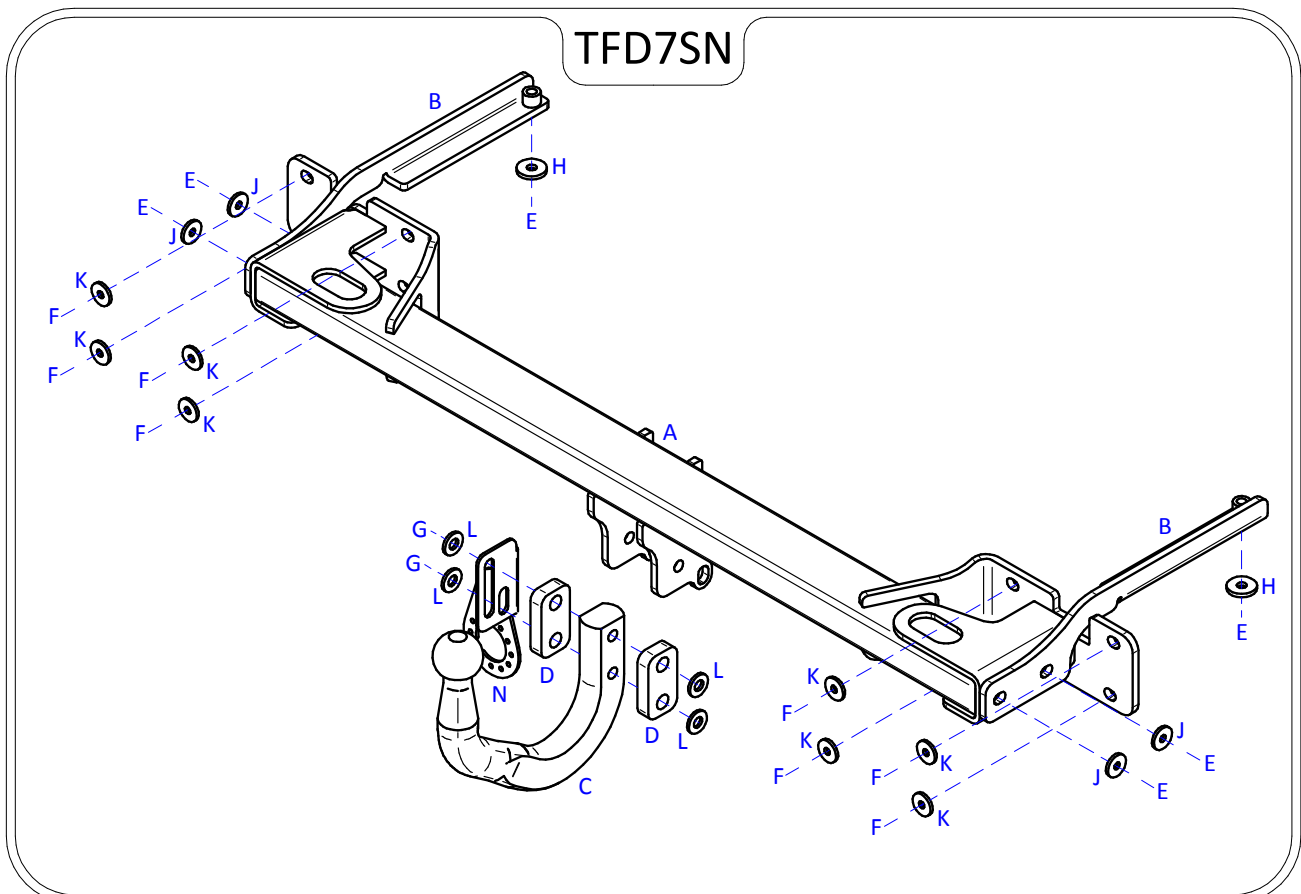

Note:

1. Recommended Torque Setting for M12 Grade 10.9 -139 Nm. (For other Torque Settings see notes overleaf.)
2. Nose load limits and vehicle manufacturers trailer / caravan weight limits must be observed.