

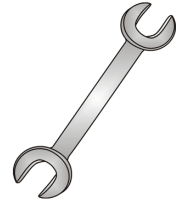

Tow-Trust Towbars

Important: Please read General Notes overleaf before fitting



Issue 1

TFD6 FORD B-MAX 2012>

| Item | Qty | Description | Item | Qty | Description |
|------|-----|----------------------------|------|-----|--|
| A | 1 | Crossmember | E | 2 | M16 x 50 Bolts, Nuts & S/P Washers |
| B | 2 | Handed Side Arms | F | 4 | M10 x 45 Bolts & S/P Washers |
| C | 2 | Handed Rear Panel Brackets | G | 6 | M8 Nuts & S/P Washers |
| D | 1 | Extension | H | 4 | M10 x 40 Bolts, 2 Nuts & 4 S/P Washers |
| | | | J | 4 | M12 x 40 Bolts & Nyloc Nuts |
| | | | K | 8 | 10 x 30 Flat Washers |
| | | | L | 6 | 8 x 25 Flat Washers |
| | | | M | 4 | 12 x 25 Flat Washers |

BUMPER REMOVAL:

1. Remove four fixings around the boot opening, six fixings along the lower edge and two fixings from each wheel arch.
2. Carefully unclip bumper from the vehicle using a bumper removal tool. (You may find it easier removing the rear tail lights when unclipping the bumper).
3. Remove bumper impact beam. (This is not refitted with the Towbar assembly)

TOWBAR INSTALLATION:

1. Insert Items **B** into each correct chassis member and fix in place using Items **F** and Items **K**. (You may gain access to the forward N/S mounting point by removing the fuel filler pipe clamps).
2. Using Items **G** with Items **L** fix Items **C** to the vehicle rear panel.
3. Insert Item **A** between Items **B** and fix in place using Items **H** and Items **K**.
4. Using Items **J** with Items **M** fix Item **D** to Item **A**.
5. Using Item **E** bolt your desired ball bracket and wiring plate (not supplied in this kit) to Item **D**.
6. Fully tighten all nuts and bolts ensuring the Towbar is rigid, square and secure.
7. Refit the rear bumper.

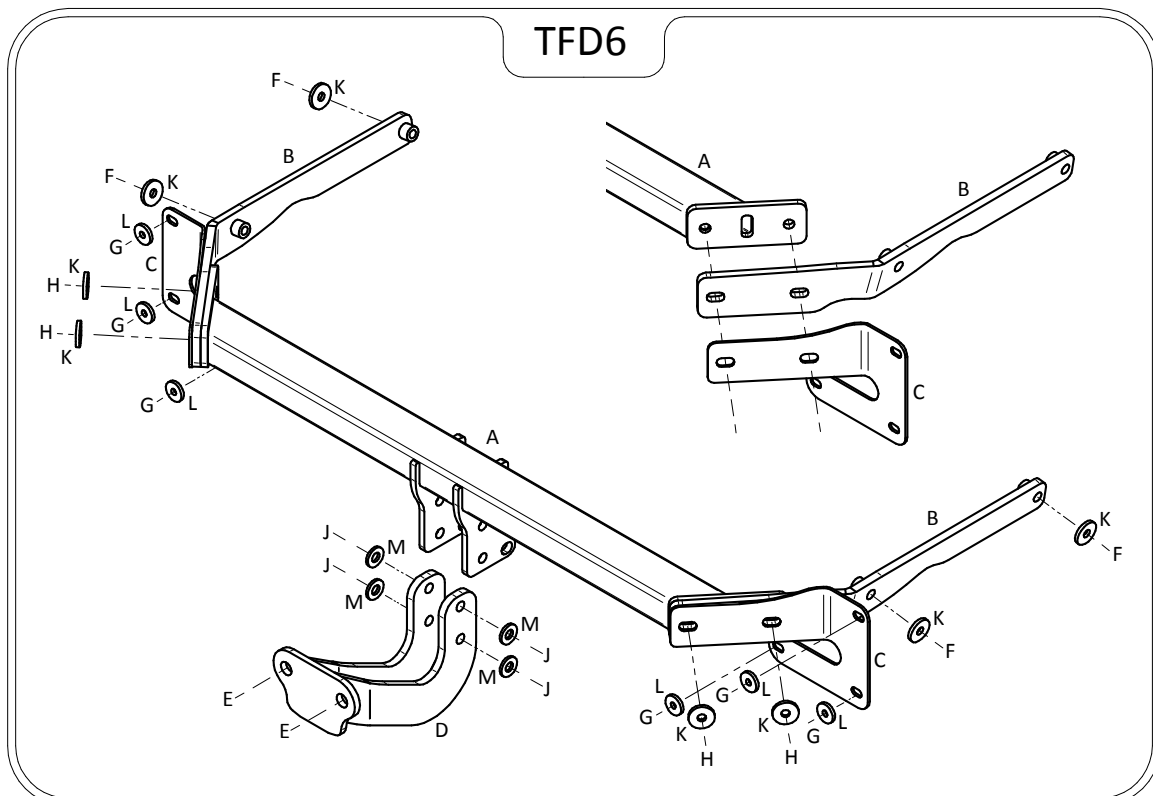

Note:

1. Recommended Torque Setting for M12 Grade 10.9 -139 Nm. (For other Torque Settings see notes overleaf.)
2. Nose load limits and vehicle manufacturers trailer / caravan weight limits must be observed.