

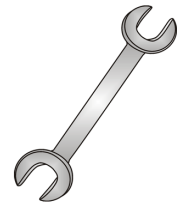

Tow-Trust Towbars

Important: Please read General Notes overleaf before fitting



Issue 2

TFD18SN FORD FOCUS 4 HATCH / FOCUS 4 ESTATE

Item	Qty	Description	Item	Qty	Description
A	1	TFD18 Crossmember	D	1	VASP8 L/H Socket Plate
B	2	Side Arms	E	4	M10 x 45 (10.9) Bolts & S/P Washers
C	1	ACS4 / 9204 Swan Neck	F	4	M12 x 45 Bolts & Nyloc Nuts
			G	2	M12 x 110 Grade 10.9 Bolts & Nyloc Nuts
			H	2	15mm Spacer Plates
			J	4	10 x 30 Flat Washers
			K	2	10 x 40 Flat Washers
			L	12	12 x 25 Flat Washers

BUMPER REMOVAL:

1. Open tailgate and remove inner trim from light cluster to reveal one bumper fixing beneath. Remove one fixing from each wheel arch liner and peel back liner to reveal one bumper fixing and one tip fixing either side of the vehicle. Note: Active models will require wheel arch trim to be carefully unclipped.
2. Remove eleven fixings from the bumper lower edge.
3. Remove the rear impact beam, this is not refitted with the Towbar assembly.

TOWBAR INSTALLATION:

1. At the rearmost mounting point only retain item K inside the chassis using Item E and Item J.
2. Insert items B into each chassis and fix at the forward mounting point only with Item E and Item J.
3. Insert Item A into the open ends of the chassis and fix through the rearmost mounting point using Items E and Item J. (Item K are used inside the chassis as spacers/ see sketch).
4. Using Item F with Item L fix Item A to Item B.
5. Using Item G with Item L and Item H fix Item C and Item D to Item A.
6. Fully tighten all fixings ensuring the Towbar is rigid, square and secure.
7. Cut the rear bumper as per the sketch below and refit.
(Estate will require an under tray Cut and the Hatch will require a heat shield cut).

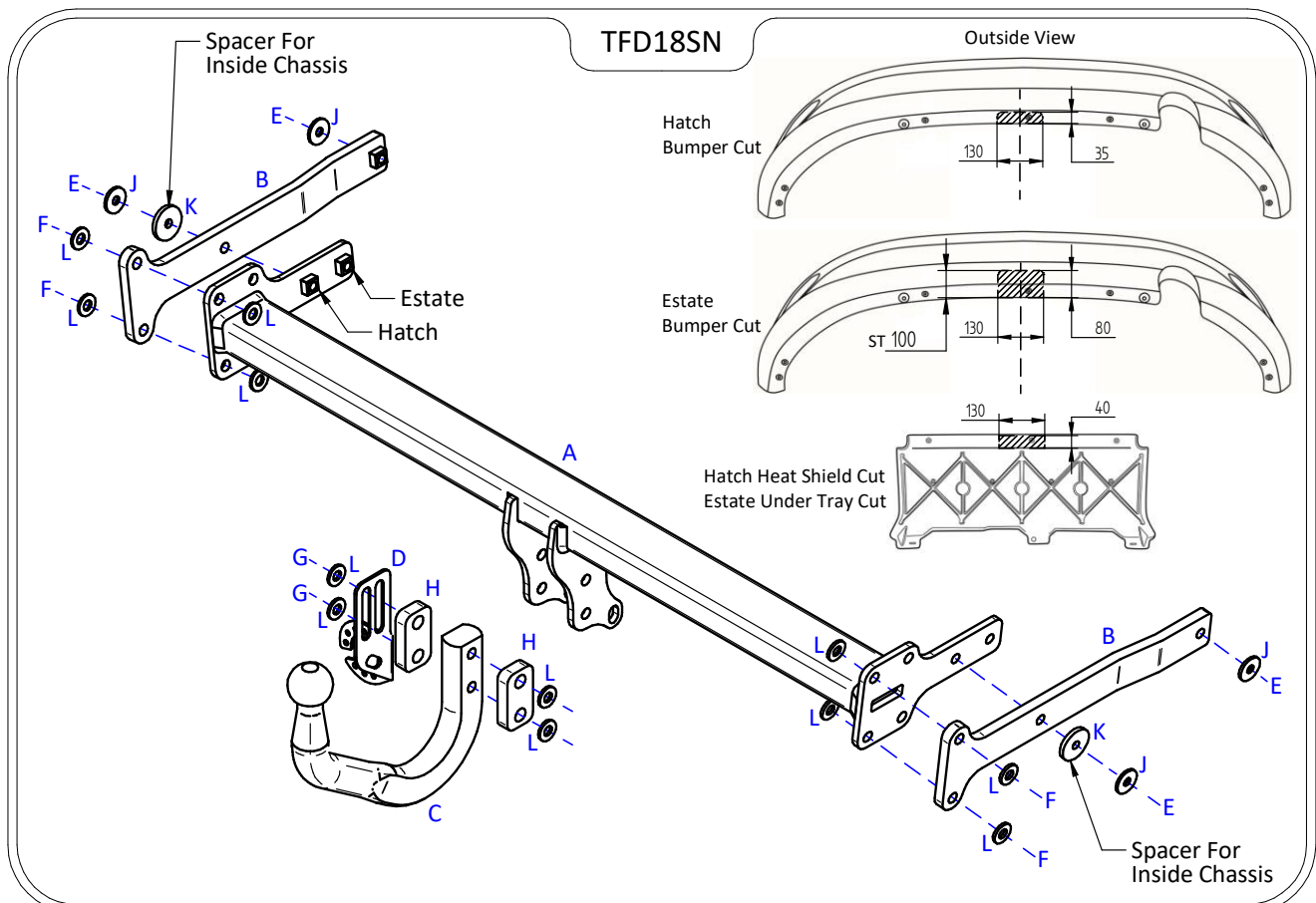

Note:

1. Torque Settings see notes overleaf.
2. Nose load limits and vehicle manufacturers trailer / caravan weight limits must be observed.