

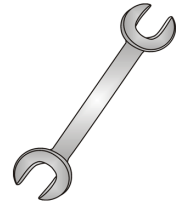

# Tow-Trust Towbars

Important: Please read General Notes overleaf before fitting



Issue 2

## TFD13VK FORD S-MAX 2015>

Item	Qty	Description	Item	Qty	Description
A	1	Crossmember	D	1	Flip Up Socket Plate (TTFP/LH)
B	2	Handed Side Arms	E	6	M10 x 45 (10.9) Bolts & S/P Washers
C	1	ACS Detachable Neck 6250	F	4	M8 x 30 Bolts (10.9) & S/P Washers
			G	4	M12 x 40 Bolts, 2 Nyloc Nuts & 2 S/P Washers
			H	2	M12 x 25 Bolts & S/P Washers
			J	2	M12 x 22 Bolts & S/P Washers
			K	6	10 x 40 Flat Washers
			L	4	8 x 25 Flat Washers
			M	8	12 x 25 Flat Washers

### BUMPER REMOVAL:

1. If fitted lower the spare wheel and remove five fixings to temporarily lower the spare wheel surround.
2. Open the tailgate; remove the black side covers on each light cluster. Remove the light clusters two fixings per light, this will expose one bumper fixing below to remove.
3. Remove five fixings per wheel arch and remove two fixings attaching the bumper to the internal bumper impact beam.
4. Release bumper tips from the vehicles body then pull rearward.
5. Remove the bumper impact beam. (This is NOT refitted with the Towbar assembly and must be handed back to the customer)
6. Lower the exhaust silencer and support to prevent damage.

### TOWBAR INSTALLATION:

1. Using Item F with Item L loosely fix Item A to the rear panel.
2. Insert Items B through the Towbar end plates and into each chassis member fixing in place using Item E with Item K.
3. Using Item G with Item M fix Items B to Item A.
4. Using Item J with Item M and Item H with Item M fix Item C and Item D to Item A.
5. Refit spare wheel surround and rehang the exhaust silencers.
6. Cut the rear bumpers lower edge as per the sketch below and refit.

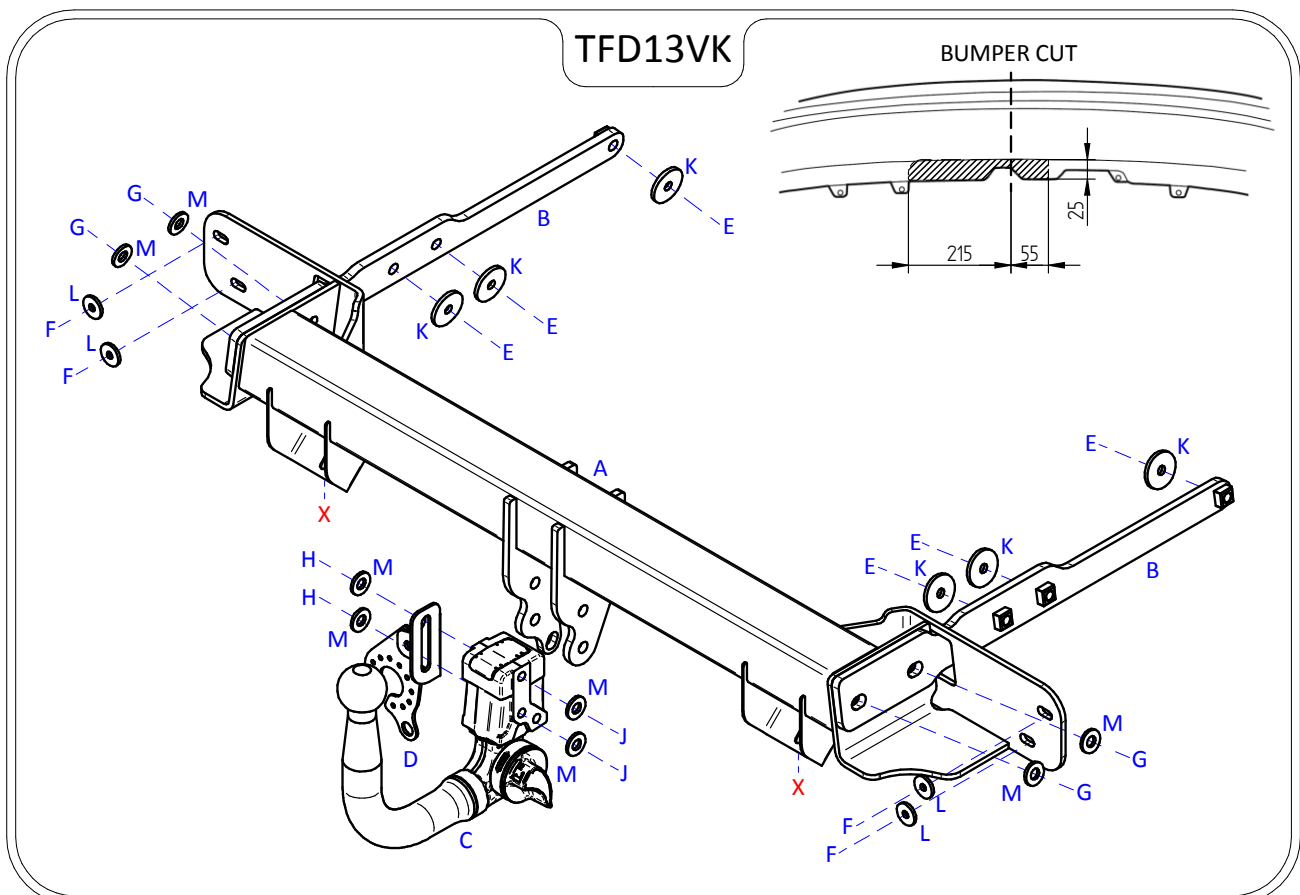

### Note:

1. Recommended Torque Setting for M12 Grade 10.9 -139 Nm. (For other Torque Settings see notes overleaf.)
2. Nose load limits and vehicle manufacturers trailer / caravan weight limits must be observed.