

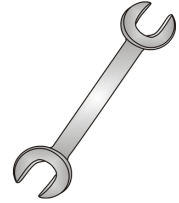

Tow-Trust Towbars

Important: Please read General Notes overleaf before fitting



Issue 1

TF177SN Ford Mondeo Estate 2007>

Item	Qty	Description	Item	Qty	Description
A	1	Crossmember	D	2	M12 x 110 Grade 10.9 Bolts & Nyloc Nuts
B	2	Handed Side Arms	E	2	15mm Spacer Plates
C	1	ACS4 / 9204 Swan Neck	F	4	M12 x 40 Bolts, 2 Nuts & 4 S/P Washers
			G	6	M10 x 40 Grade 10.9 Bolts & S/P Washers
			H	4	12 x 25 Flat Washers
			J	6	10 x 40 Flat Washers
			K	1	VASP8 L/H Socket Plate

1. Remove rear bumper. Two fixings on lower edge, three fixings around each wheel arch and four fixings along top edge. Pull bumper tips out from body clips and then pull rearwards.
2. Remove bumper beam. (This is not refitted with the towbar).
3. Lower rearmost exhaust box.
4. Remove heat shield.
5. Locate Item B into each chassis and using Item G with Item J loosely bolt into place through existing holes.
6. Using Item F bolt Item A to Item B.
7. Using Item D with Item H and Item E bolt Item C with Item K to Item A.
8. Fully tighten all nuts and bolts and ensure the towbar is rigid and secure.
9. Cut a section from the lower edge of the bumper (see sketch). **2011> NO CUT REQUIRED.**
10. Refit heat shield, exhaust and rear bumper.

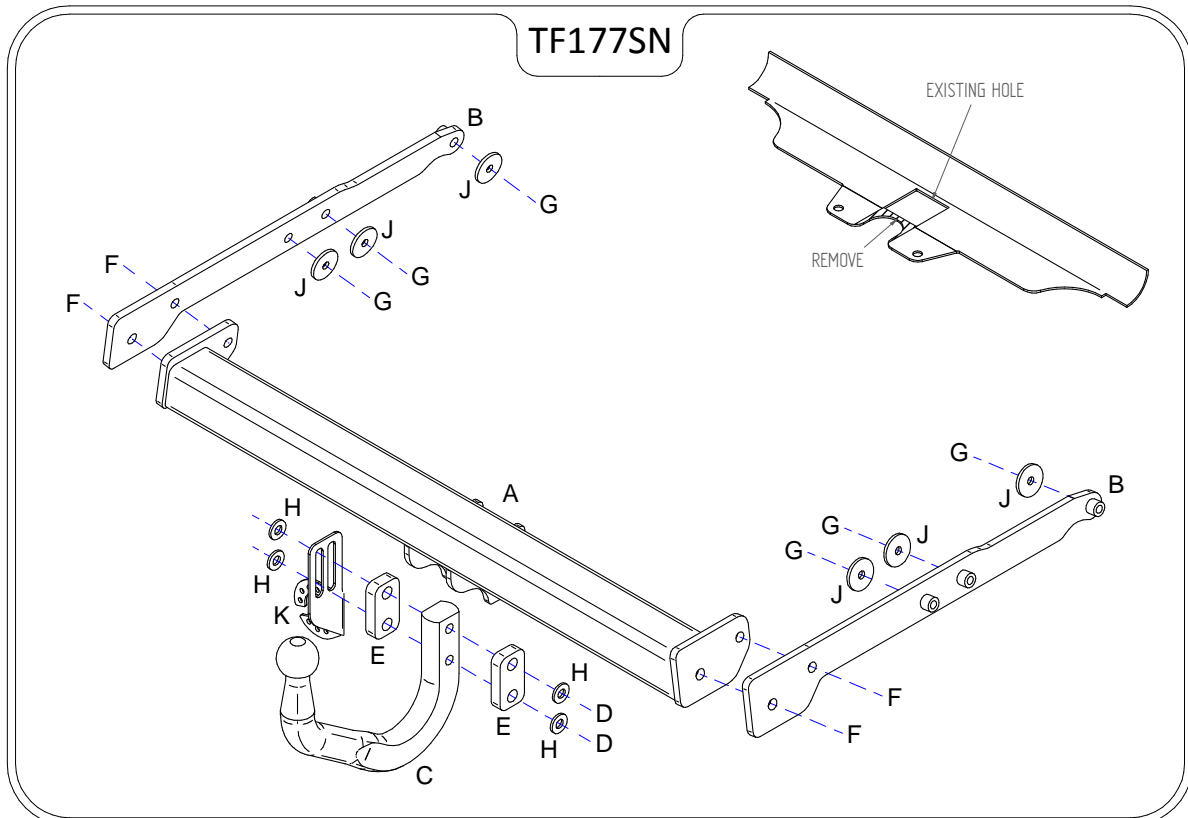

Note:

1. Recommended Torque Setting for M10 Grade 10.9 -78 Nm M12 Grade 10.9 -139 Nm.
2. Nose load limits and vehicle manufacturers' trailer / caravan weight limits must be observed.