

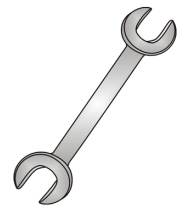

Tow-Trust Towbars

Important: Please read General Notes overleaf before fitting



Issue 5

TF161 Ford Mondeo Estate 2001 - 2007

| Item | Qty | Description | Item | Qty | Description |
|------|-----|------------------------|------|-----|--|
| A | 1 | Crossmember | E | 2 | M16 x 50 Bolts Nuts & S/P Washers |
| B | 2 | Side Arms | F | 6 | M10 x 130 Bolts, Nuts & S/P Washers |
| C | 1 | Extension Bar | G | 2 | M12 x 85 Grade 10.9 Bolts & Nyloc Nuts |
| D | 6 | 17mm x 93 Spacer Tubes | H | 6 | M12 x 30 Bolts, 4 Nuts & 6 S/P Washers |
| | | | J | 6 | 10 x 40 Flat Washers |
| | | | K | 4 | 12 x 25 Flat Washers |

1. Remove the fasteners securing the lower bumper. Cut a slot in the lower bumper 60mm x 120mm (see sketch).
2. Lower the exhaust at the rear fixing and remove the heat shield.
3. Remove any mastic from around the three existing holes in each chassis.
4. Using item F with item J and item D located into the chassis, loosely bolt item B to the inside face of each chassis member (ensure the bolts locate into the slot provided).
5. Locate item A into the bumper and using item H, bolt item A to item B.
6. Fully tighten all nuts and bolts and ensure the towbar is rigid and secure.
7. Re-fit the heat shield, exhaust and bumper fasteners.
8. Using item G with item K bolt item C to item A.
9. Using item E bolt the ball bracket and wiring plate (not supplied in this kit) to the mounting plate.

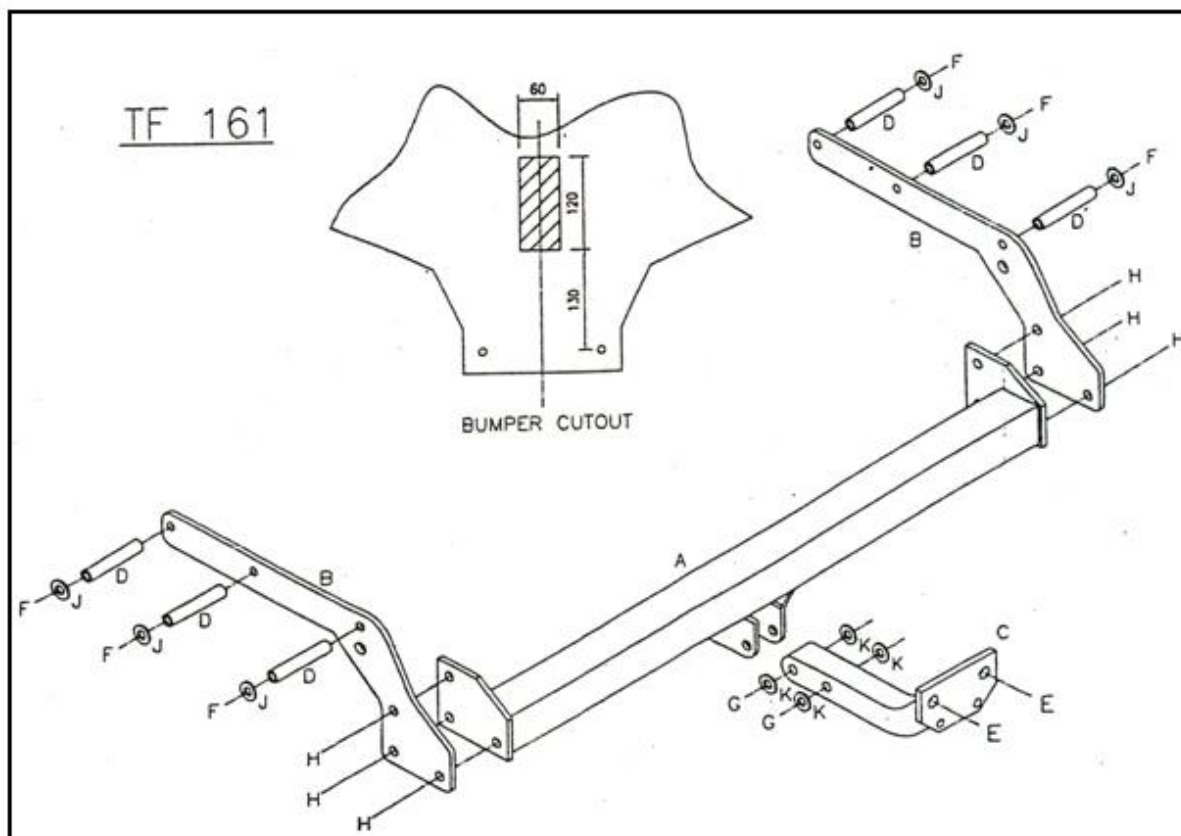

Note:

1. Recommended Torque Setting for M12 Grade 10.9 -139 Nm. (For other Torque Settings see notes overleaf.)
2. Nose load limits and vehicle manufacturers trailer / caravan weight limits must be observed.