

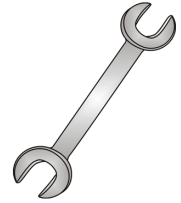

Tow-Trust Towbars

Important: Please read General Notes overleaf before fitting



Issue 2

TBMW1VK BMW X1 (E84) 2009>

Item	Qty	Description	Item	Qty	Description
A	1	Crossmember	C	2	M12 x 25 Bolts & S/P Washers
B	1	Detachable Housing	D	2	M12 x 22 Bolts & S/P Washers
			E	4	12 x 25 Flat Washers
			F	1	Flip Up Socket Plate (TTFP/RH)
			X	6	Original Fixings
			Y	6	Large Plastic Rivets

BUMPER REMOVAL:

1. Remove the rear light clusters, three fixings found inside the boot.
2. Remove nine fixings along the lower edge of the bumper, six fixings around wheels arches and one tip fixings each side.
3. Support the rear exhaust silencer and remove the rearmost rubber hanger.
4. Remove rear crash beam and retain fixings and gaskets ready for fitting Item A to the rear panel. (Crash beam is not refitted).

TOWBAR INSTALLATION:

1. Using the original fixings (Item X) bolt Item A to the rear panel sandwiching the original gaskets between and fully tighten.
2. Rehang the rear exhaust silencer to the mounting point on Item A.
3. Using Item C with Item E and Item D with Item E bolt Item B and Item F to Item A.
4. Fully tighten the remaining fixings ensuring the Towbar is rigid, square and secure.
5. Refit the rear bumper and light clusters.

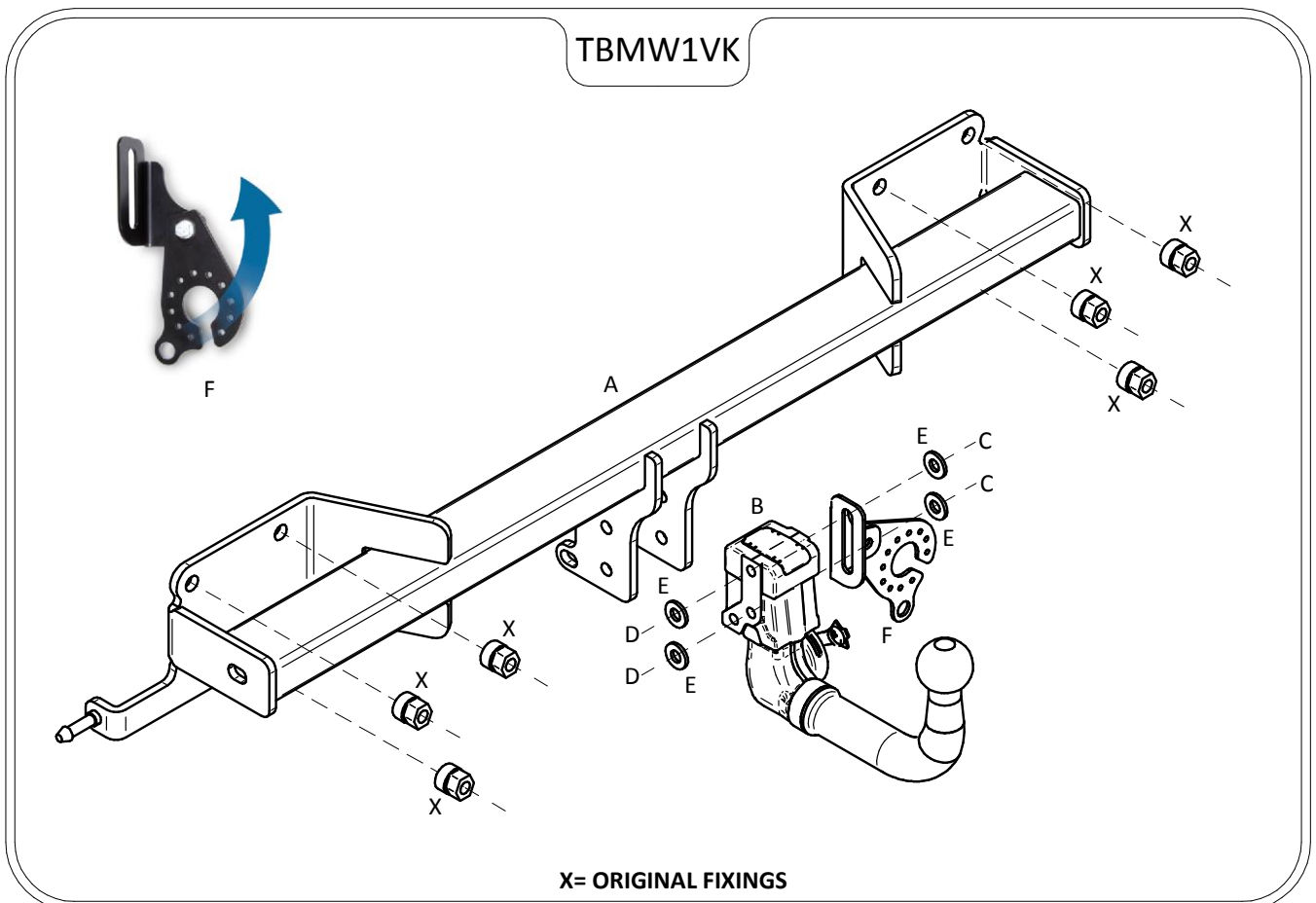

Note:

1. Recommended Torque Setting for M12 Grade 10.9 -139 Nm. (For other Torque Settings see notes overleaf.)
2. Nose load limits and vehicle manufacturers trailer / caravan weight limits must be observed.