

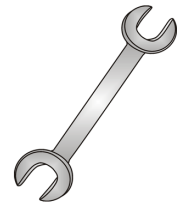

Tow-Trust Towbars

Important: Please read General Notes overleaf before fitting



Issue 1

TAD6 AUDI A6 (C8) 2018> / A7 (F2) 2018>

Item	Qty	Description	Item	Qty	Description
A	1	TAD6 Crossmember	D	2	M16 x 50 Bolts & Nyloc Nuts
B	2	Handed Side Arms	E	2	M12 x 60 Bolts & S/P Washers
C	1	Extension	F	6	M12 x 40 (10.9) Bolts, 4 Nyloc Nuts & 2 S/P Washers
			G	1	M12 x 100 Bolt & Nyloc Nut
			H	2	M12 x 40 Bolts & Nyloc Nuts
			J	4	12 x 30 Flat Washers
			K	12	12 x 25 Flat Washers
			L	1	30mm O/D x 34.5mm Long Spacer Tube
			M	4	100 x 2.5 Black Zip Ties

REMOVE REAR BUMPER:

1. Remove rear light clusters; remove the black inner plastic trim to reveal two fixings per light cluster.
2. Remove three fixings from each wheel arch, peel back wheel arch liner to reveal one tip fixing either side. Remove six fixings along bumper lower edge.
3. Carefully release the bumper from the vehicle body and pull rearwards disconnecting any necessary wiring looms.
4. Remove the rear impact beam (this is not refitted with the Towbar assembly). Replace fixings into rear panel to prevent water ingress.

TOWBAR INSTALLATION:

1. Insert Items B into each correct chassis member and fix through the rearmost mounting point using Item F with Item J, fix at the forward mounting point using Item E with Item J.
2. Fix Item A between each side arm using Items F with Items K. (Cut the heat shield as per FIG:2, NOTE: these can come pre-cut)
3. Fix Item C to Item A using Items H with Items K and Item G with Items K ensuring Item L is fitted between the lowest mounting point.
4. Fully tighten all fixings ensuring the Towbar is rigid, square and secure.
5. Cut the rear bumper as per FIG:1 and refit. NOTE: these can come pre-cut.
6. Using Item D fix your desired ball bracket and wiring plate (Not supplied in this kit) to Item C and fully tighten.

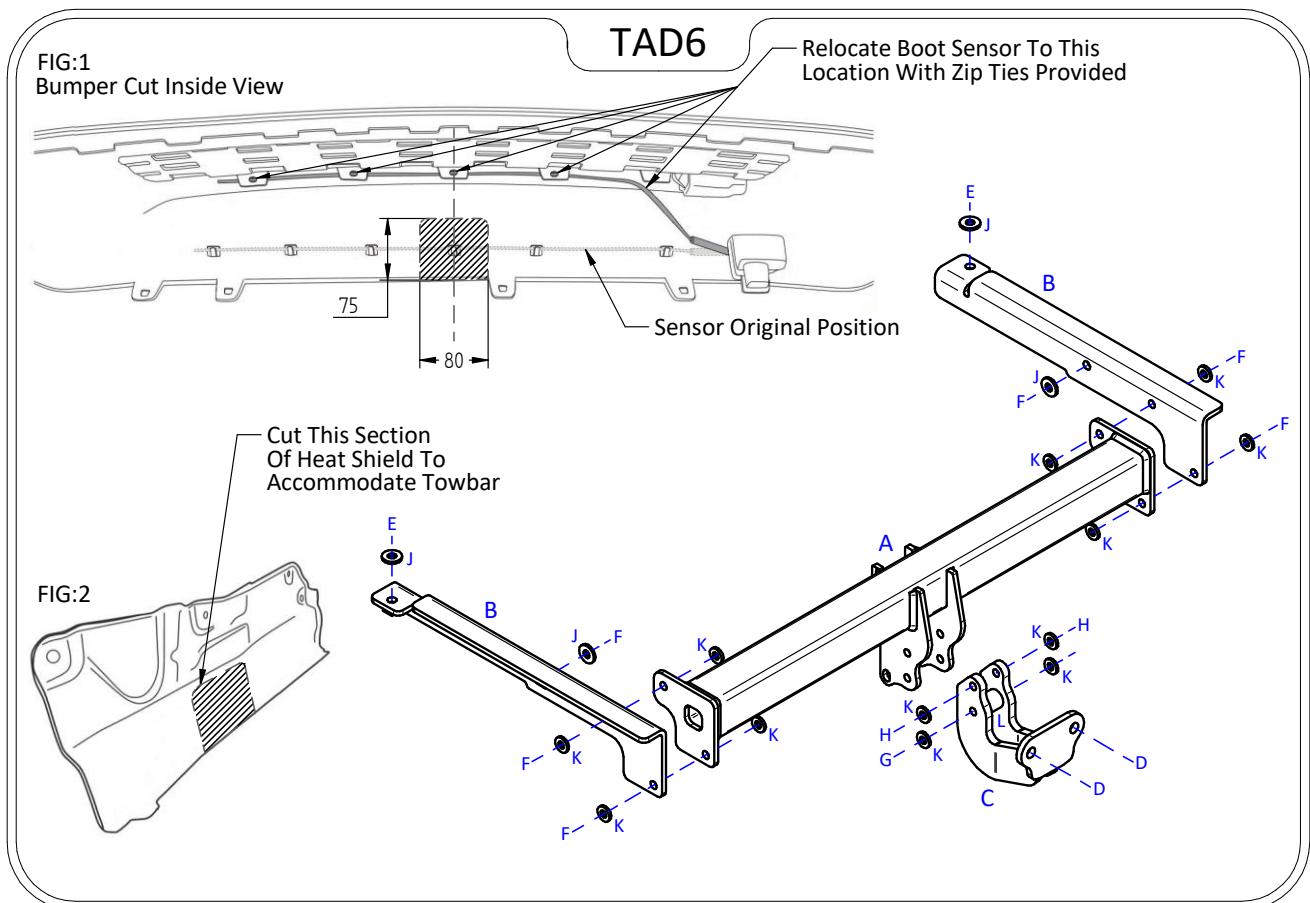

Note:

1. Torque Settings see notes overleaf.
2. Nose load limits and vehicle manufacturers trailer / caravan weight limits must be observed.