

# UNIVERSAL HITCHES

from Dixon-Bate



**All universal hitches from Dixon-Bate meet the highest requirements in terms of quality and longevity. They are therefore outstandingly suitable for commercial purposes. End customers can also fasten these hitches to their towing vehicles quickly.**

The universal hitches consist of a separate 50 mm towball and a coupling bolt with a diameter of 25 mm. Manufactured from durable forged steel, the towball/bolt assembly has been one of the most popular products amongst commercial users for the past 20 years. The universal hitches from Dixon-Bate are available with or without a hardened coupling bolt.

## FEATURES AND ADVANTAGES

- | Unique hitch with towball and coupling bolt
- | All hitches meet the requirements of Directive ECE-R55-01
- | Galvanised as well as transparent passivated surface
- | Class: A50-X/S

### Universal 3.5 t hitch with 25mm bolt



- | Bolt diameter: 25 mm
- | Ball diameter: 50 mm
- | Trailer load: 3.5 t
- | D value: 17.2 kN
- | Vertical load/S value: 250 kg
- | Drawbar eye: min. internal diam. 28,6 mm  
Maximum cross-section: 28.6 mm
- | 2-bolt mounting as per Directive ECE-R55-01



Bolts not included in scope of delivery.  
Strength class 8.8 or higher required.

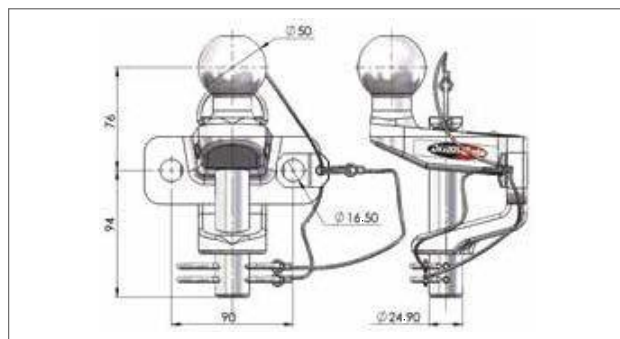

### Universal 3.5 t hitch with hardened 25 mm bolt



- | Bolt diameter: 25 mm
- | Ball diameter: 50 mm
- | Trailer load: 3.5 t
- | D value: 17.2 kN
- | Vertical load/S value: 250 kg
- | Drawbar eye: min. internal diam. 28,6 mm  
Maximum cross-section: 28.6 mm
- | 2-bolt mounting as per Directive ECE-R55-01



Bolts not included in scope of delivery.  
Strength class 8.8 or higher required.

Part no.	Product
185002015 (Bradley DB202014) SAP: BALL & PIN 3500KG DIXON BATE	Universal 3.5 t hitch with 25 mm bolt
185009815 (Bradley DB201740) SAP: COUPLING 3.5T UNIV HARDPIN DB	Universal 3.5 t hitch with hardened 25 mm bolt (designed for 3,500 kg)

Replacement part no.	Product
185012815 (Bradley DB68121) SAP: 25 MM BOLZEN 3500KG + SICHERUNGSSET	25 mm standard bolt/ lanyard/strap/split pin
185012915 (Bradley DB68129) SAP: KETTE/LASCHE/SPLINT 3500KG	Lanyard/strap/split pin for 25 mm bolt (standard head and hardened bolt)
185013015 (Bradley DB67229) SAP: 25MM BOLZEN GEHÄRTET + SICHERUNGSSET	Hardened 25 mm bolt/ lanyard/strap/split pin