

Citroën Berlingo 06/2015-
Peugeot Partner 06/2015-

Partnr.: CT-056-D1U

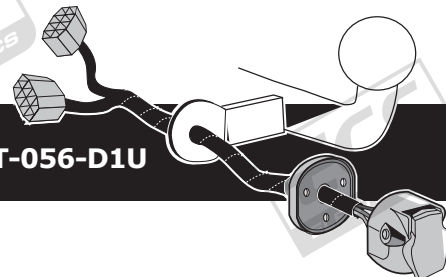

- Fitting instructions electric wiring kit tow bar with 13-P socket up to DIN/ISO Norm 11446.
- We would expressly point out that assembly not carried out properly by a competent installer will result in cancellation of any right to damage compensation, in particular those arising by virtue of the product liability act.
- Contents of these kits and their fitting manuals are subject to alteration without notice, please ensure that these instructions are read and fully understood before commencing installation.
- Do not overload circuits; the maximum loads per connection are detailed in this manual.
- Attention! Before Installation, please read this manual carefully and inform your customer to consult the vehicle owners manual to check for any vehicle modifications required before towing.
- In the event of functional problems, troubleshooting must be limited to about 0.5 hours, contact the technical support:
t.skinner@ecs-electronics.com / 07440 202 052.



ROUTING

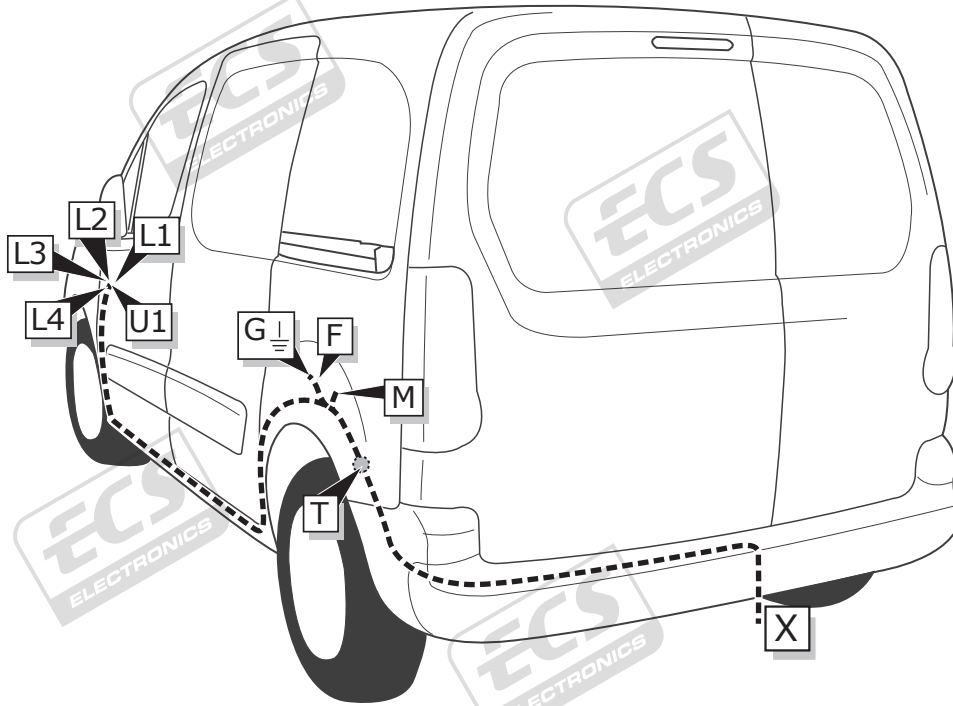

1

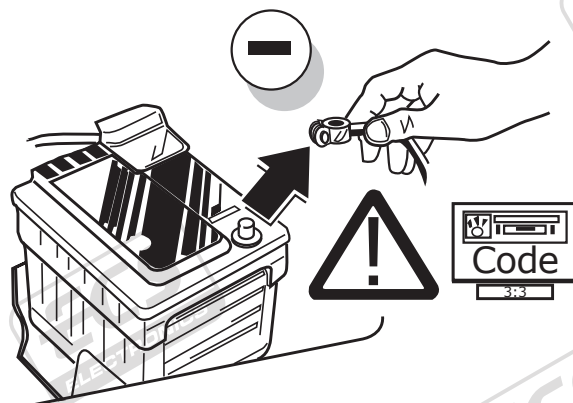

2

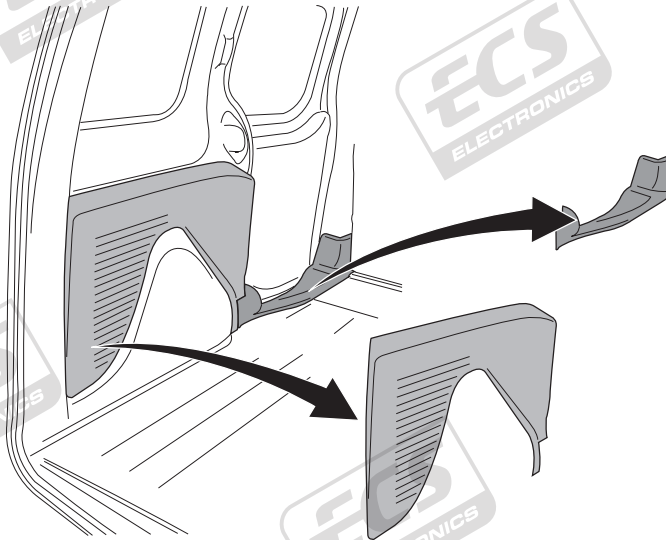
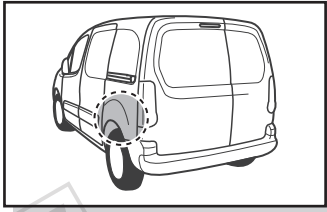

3

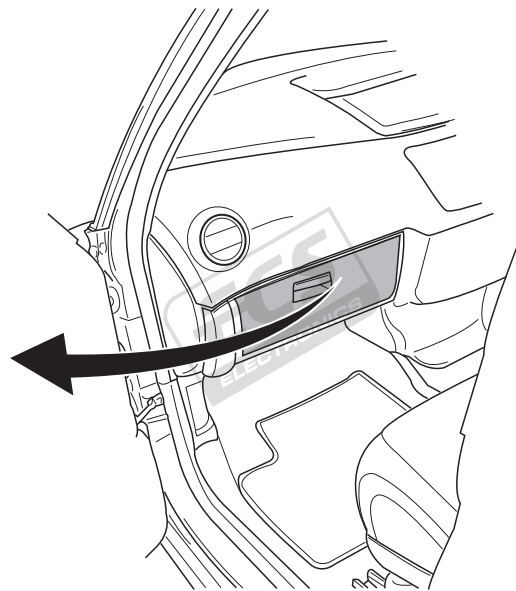
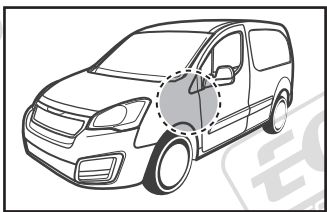

4

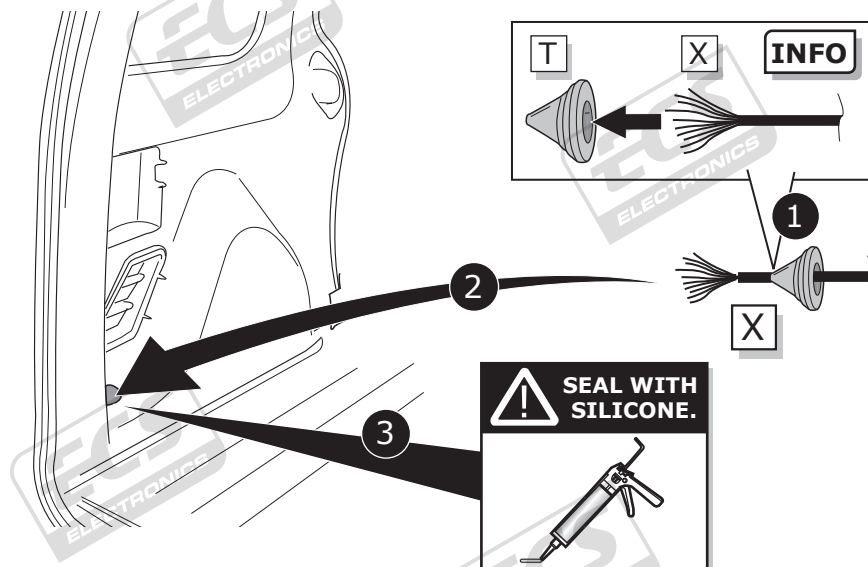
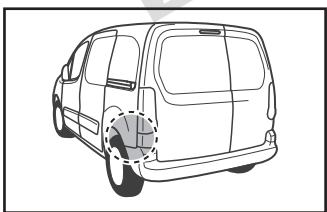

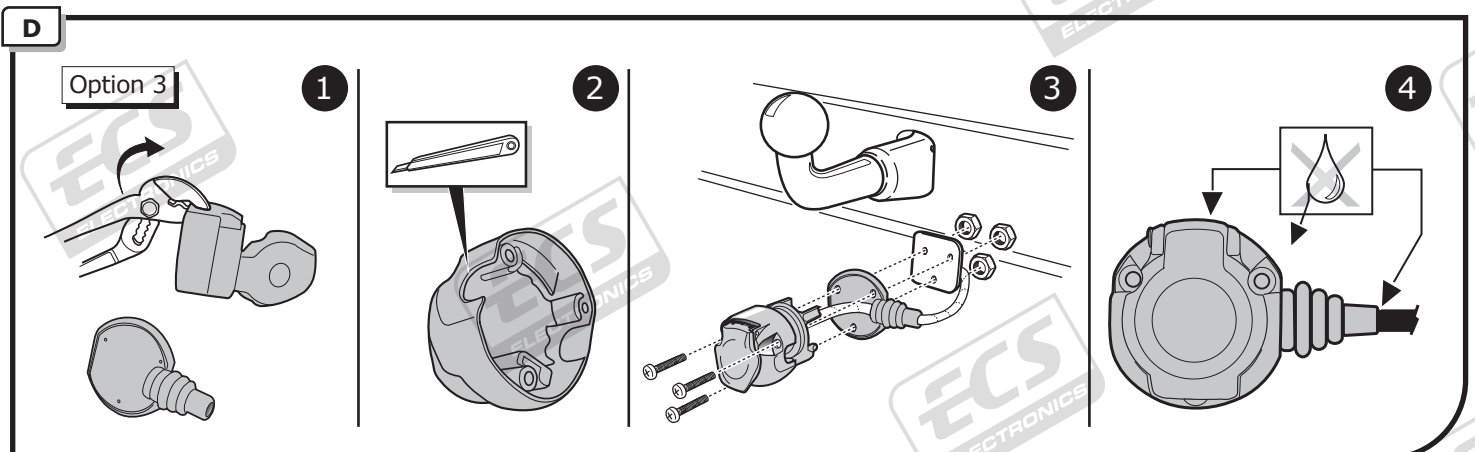
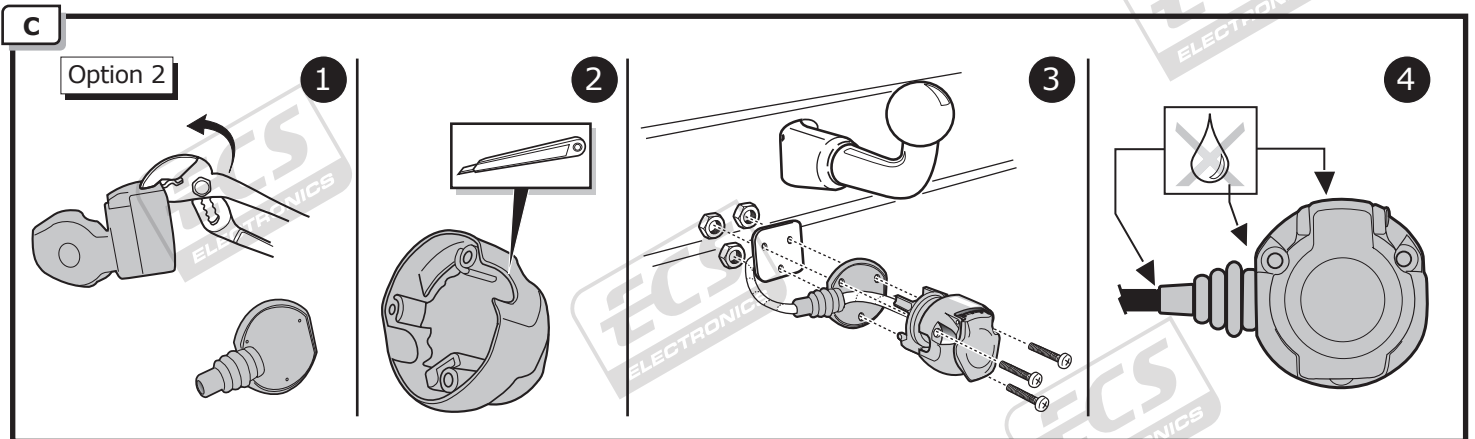
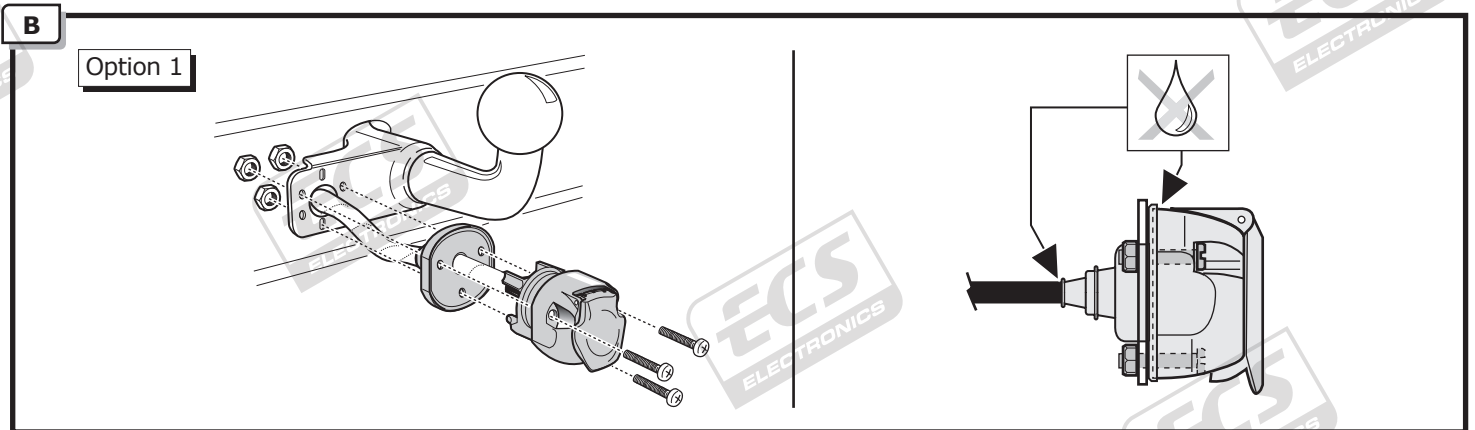
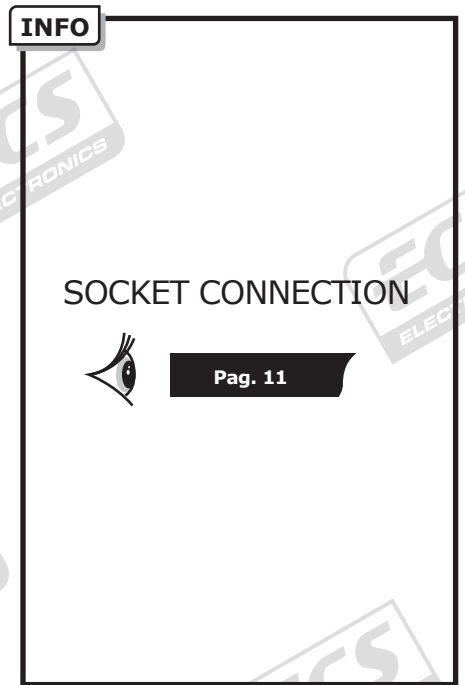
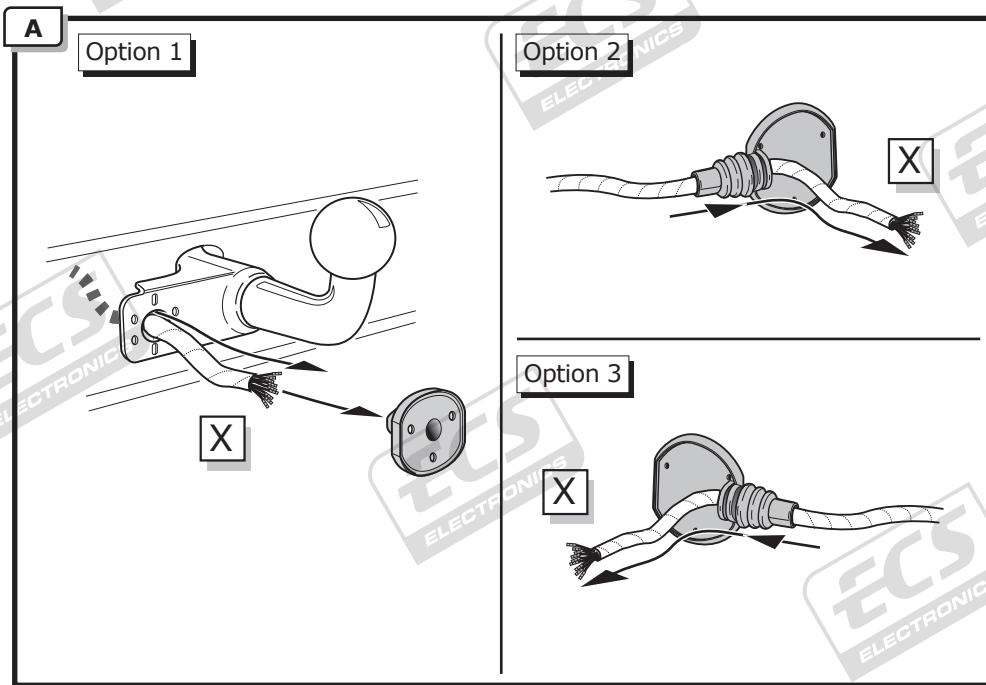

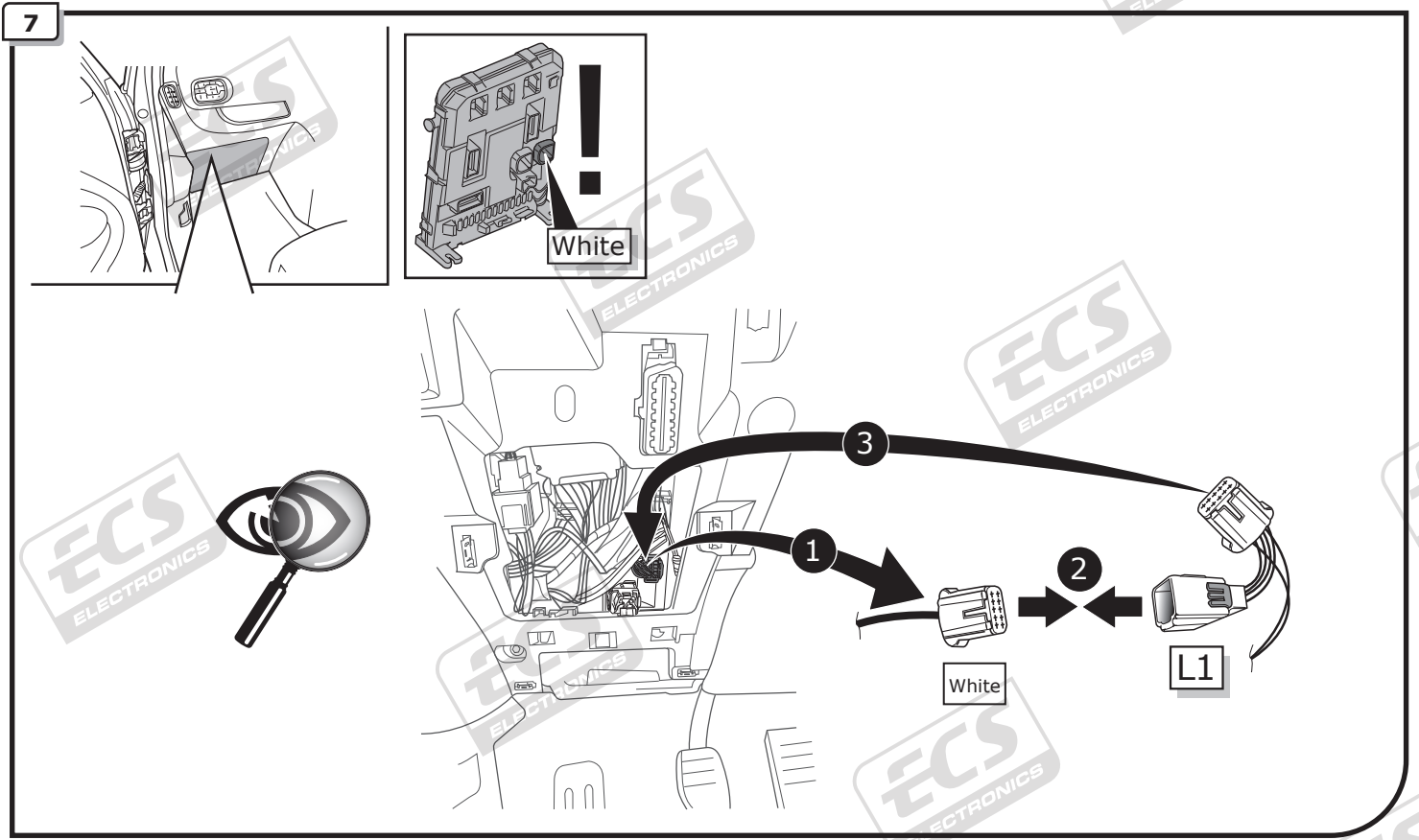
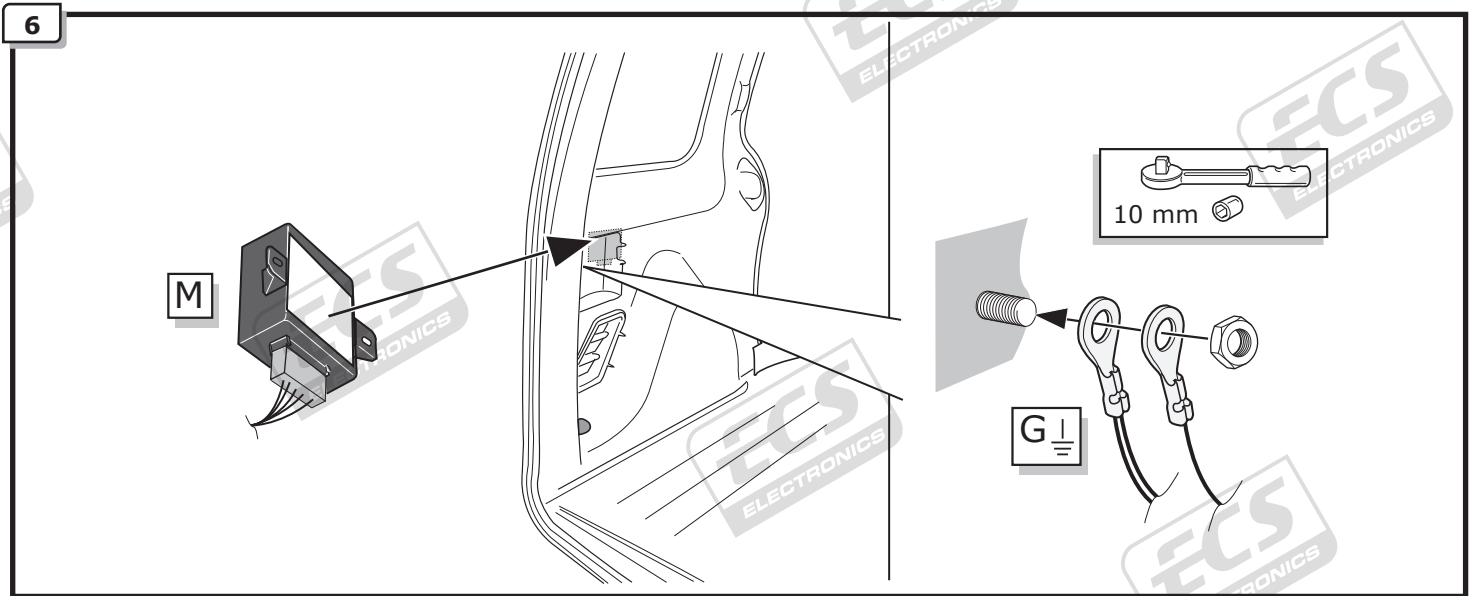
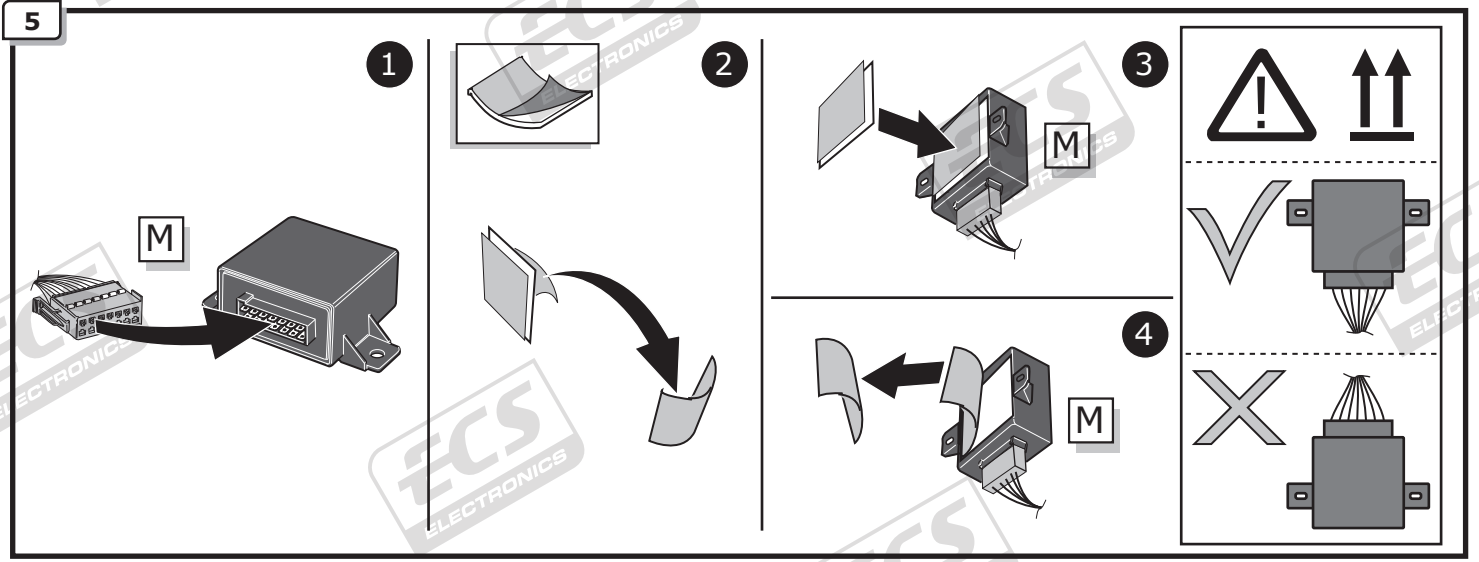

8

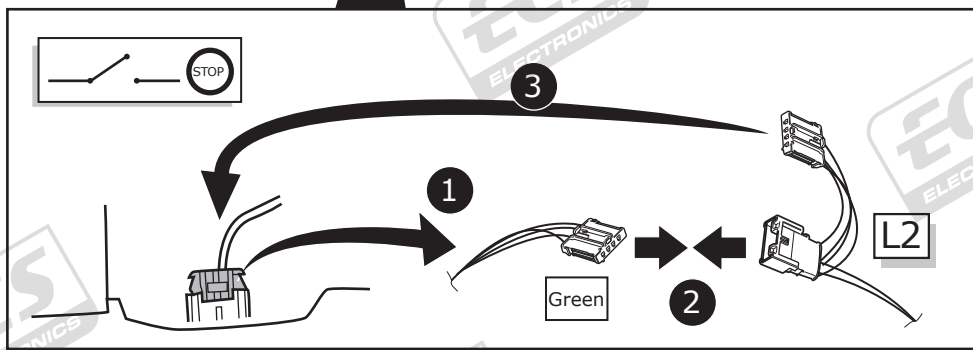
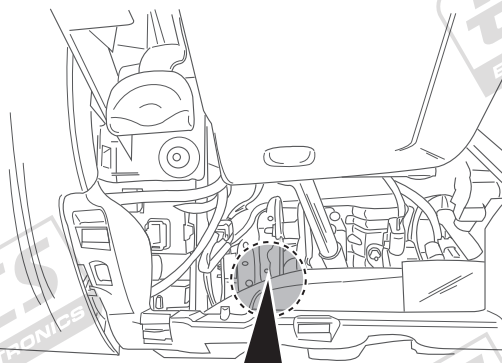
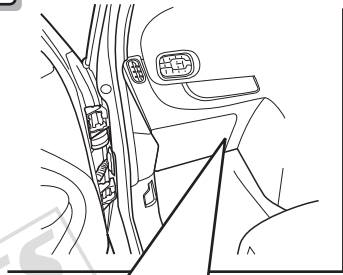

9

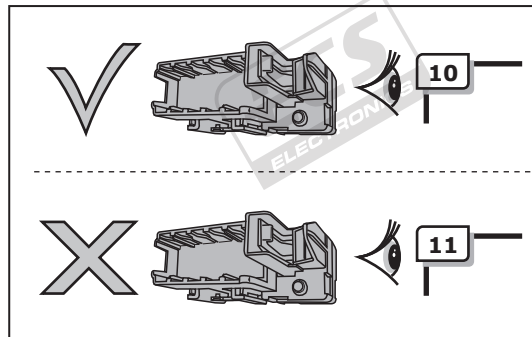
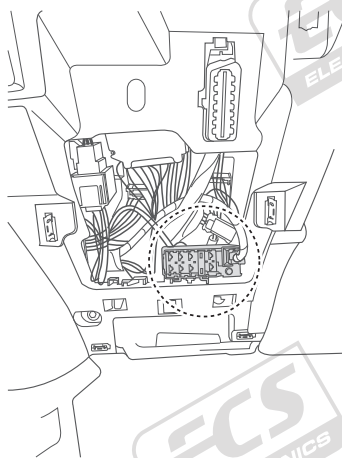
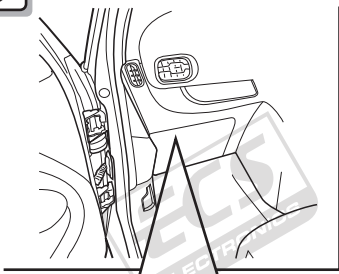

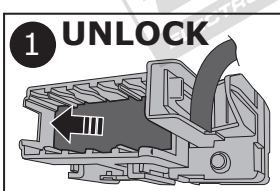
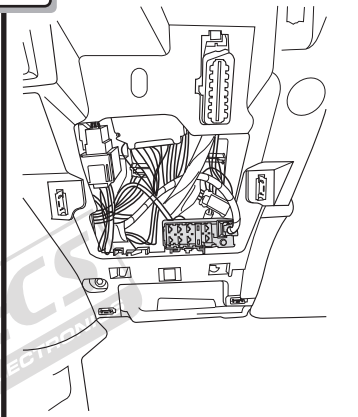

! Choose free position

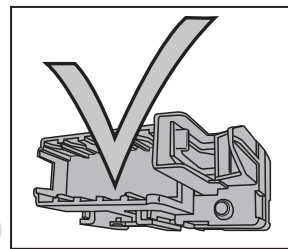
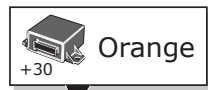
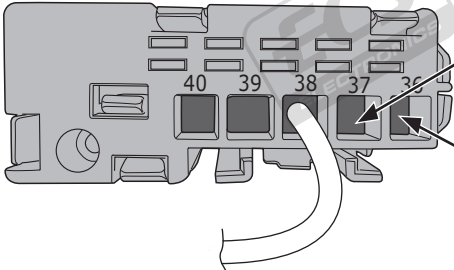

5

Position

User guide.

4

20 Amp. x2

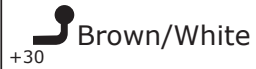
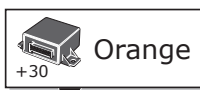
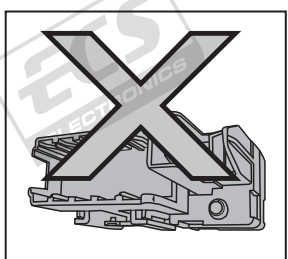
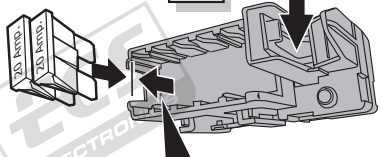
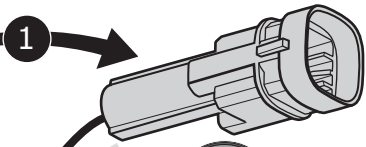
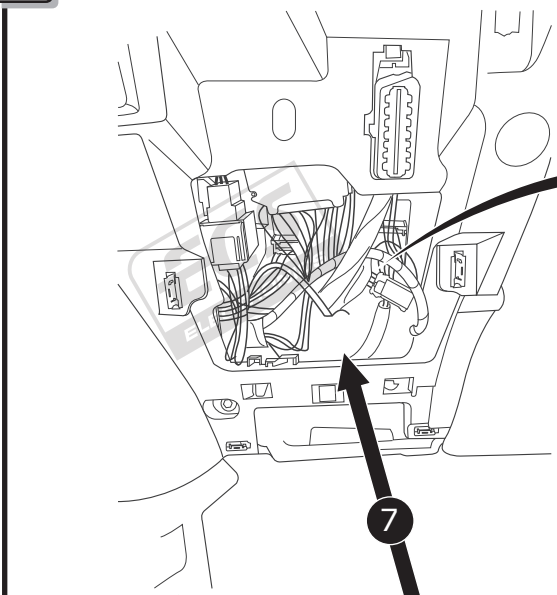
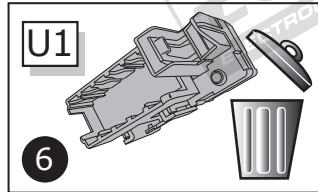
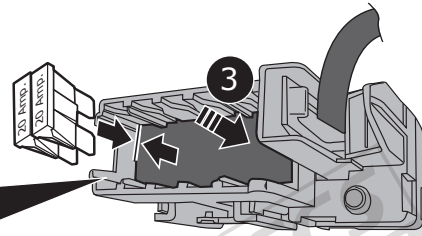

6

Position

User guide.

5

20 Amp. x2

12

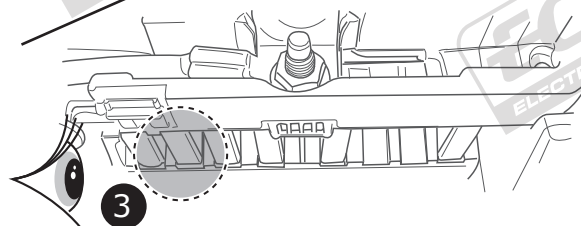
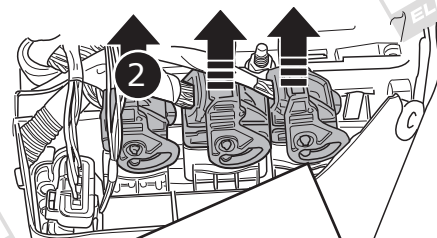
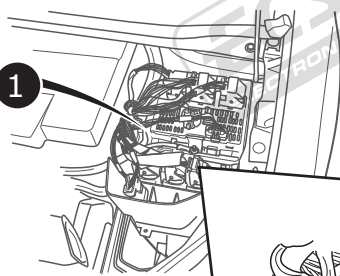
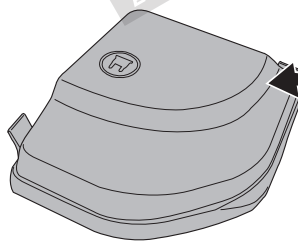
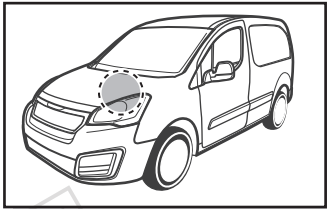

4

Pos. 2

Option 1	Option 2

13

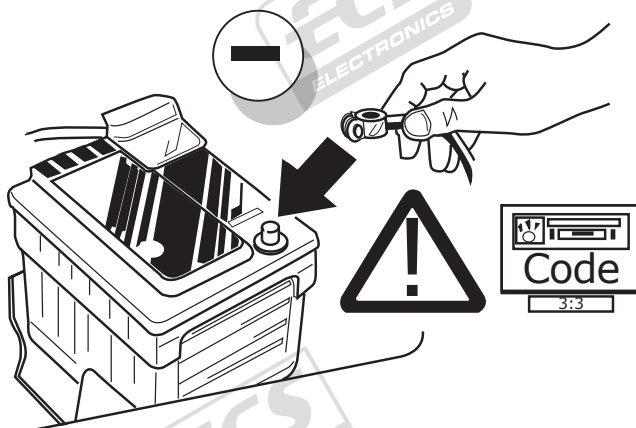

14



TEST ALL THE CIRCUITS WITH A TEST DEVICE WITH THE CORRECT POWER LOAD FOR EACH FUNCTION. A TEST DEVICE WITH LED'S CANNOT BE USED FOR THIS PURPOSE.

INFO

REINSTALL TRIM.

INFO

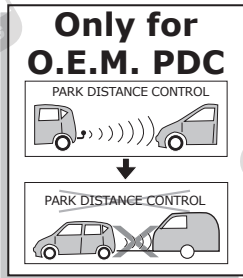

C2

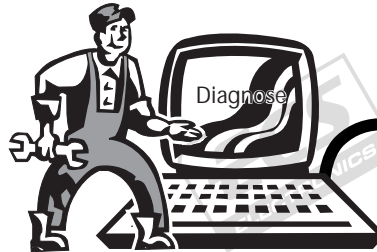

15

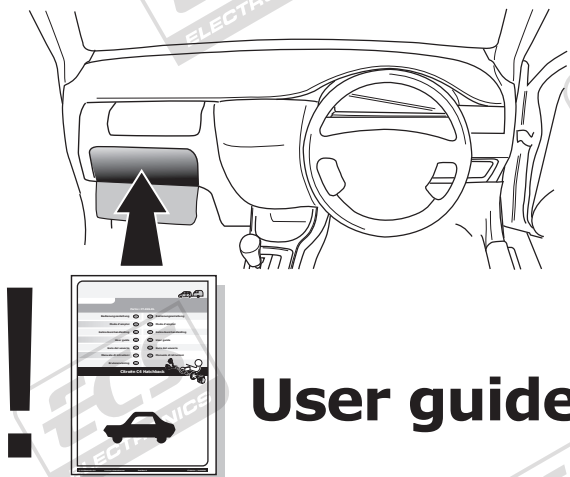

User guide



OPTION

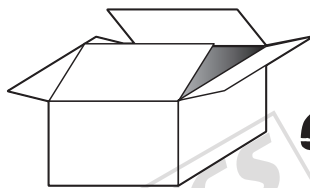
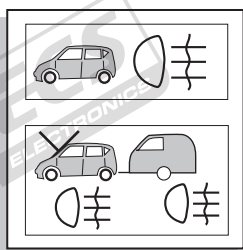

SP-161-ZZ

Consult your supplier.

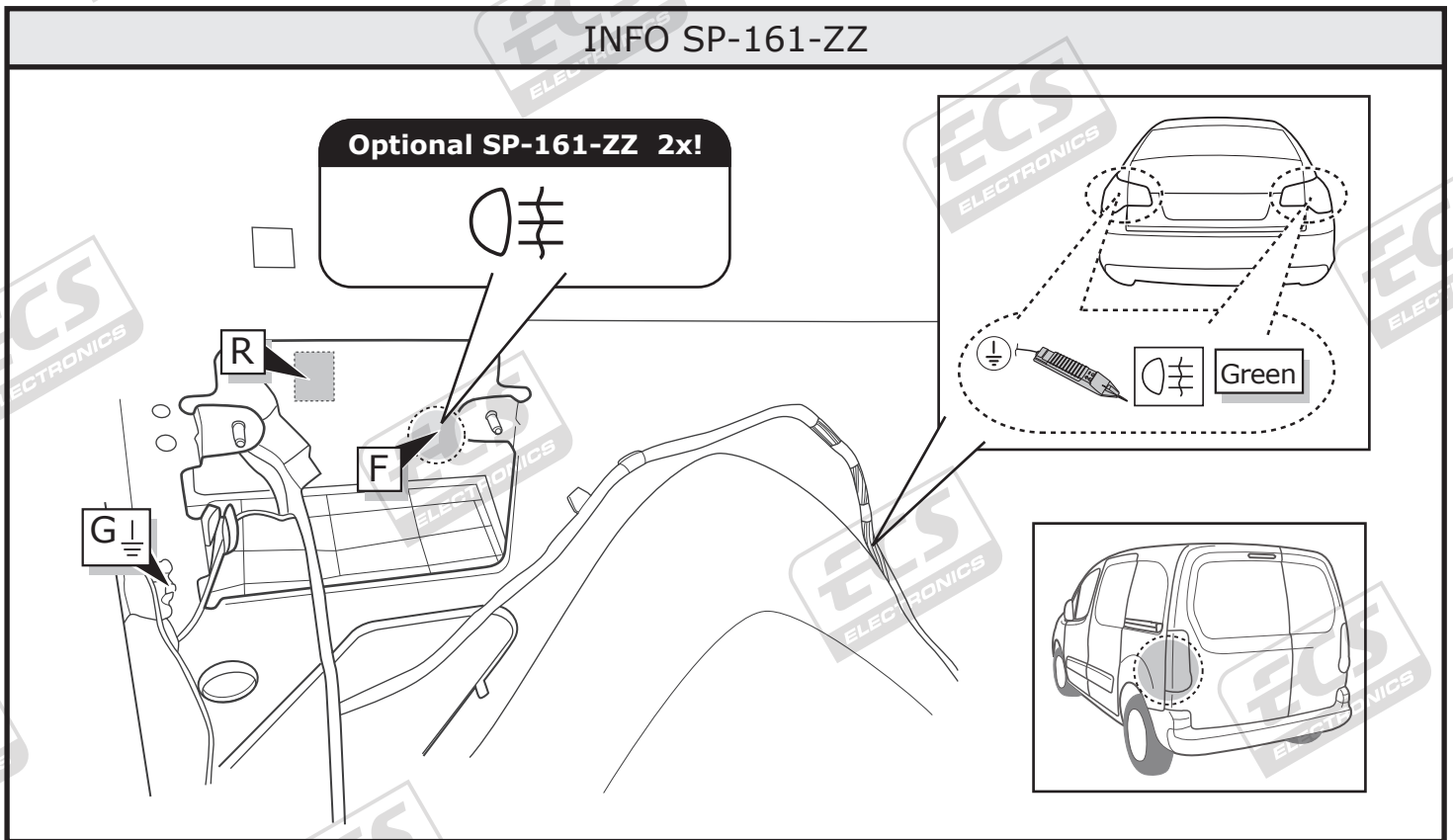

INFO

SOCKET CONNECTION

DIN/ISO 11446													
	1/L	2	3/31	4/R	5/58-R	6/54	7/58-L	8	9	10	11	12	13
Pmax	21W	21W		21W	42W	3x21W	42W	21W	180W/15Amp	180W/15Amp			
Colour	Yellow	Blue	White	Green	Brown	Red 1,00 mm ²	Black	Black/ Red	Brown/ White	Red 2,50 mm ²	White	-	White

INFO POWER SCHEDULE CT-056-D1U

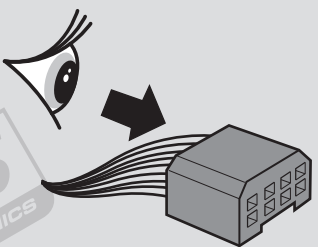

L	←	54	STOP
R	→	54G	⚡
58L	⚡	BU	⊕ _R
58R	⚡	Ground/31	⊖

