



**MEDIC
THERAPEUTICS**

AIR PURIFIER

ACTIVATED CARBON HEPA H13 FILTRATION

Manual



Please Read Manual Prior to Use

BEFORE USE

The Medic Therapeutics Air Purifier can help you achieve a healthy and comfortable living and working environment. Air purifiers are an effective, safe way to eliminate the contaminants that create indoor air pollution.

The air inlets on all four sides and the outlet structure on top of the unit provide comprehensive and highly effective air circulation. Welcome to a healthier living and working environment.

PRODUCT STRUCTURE

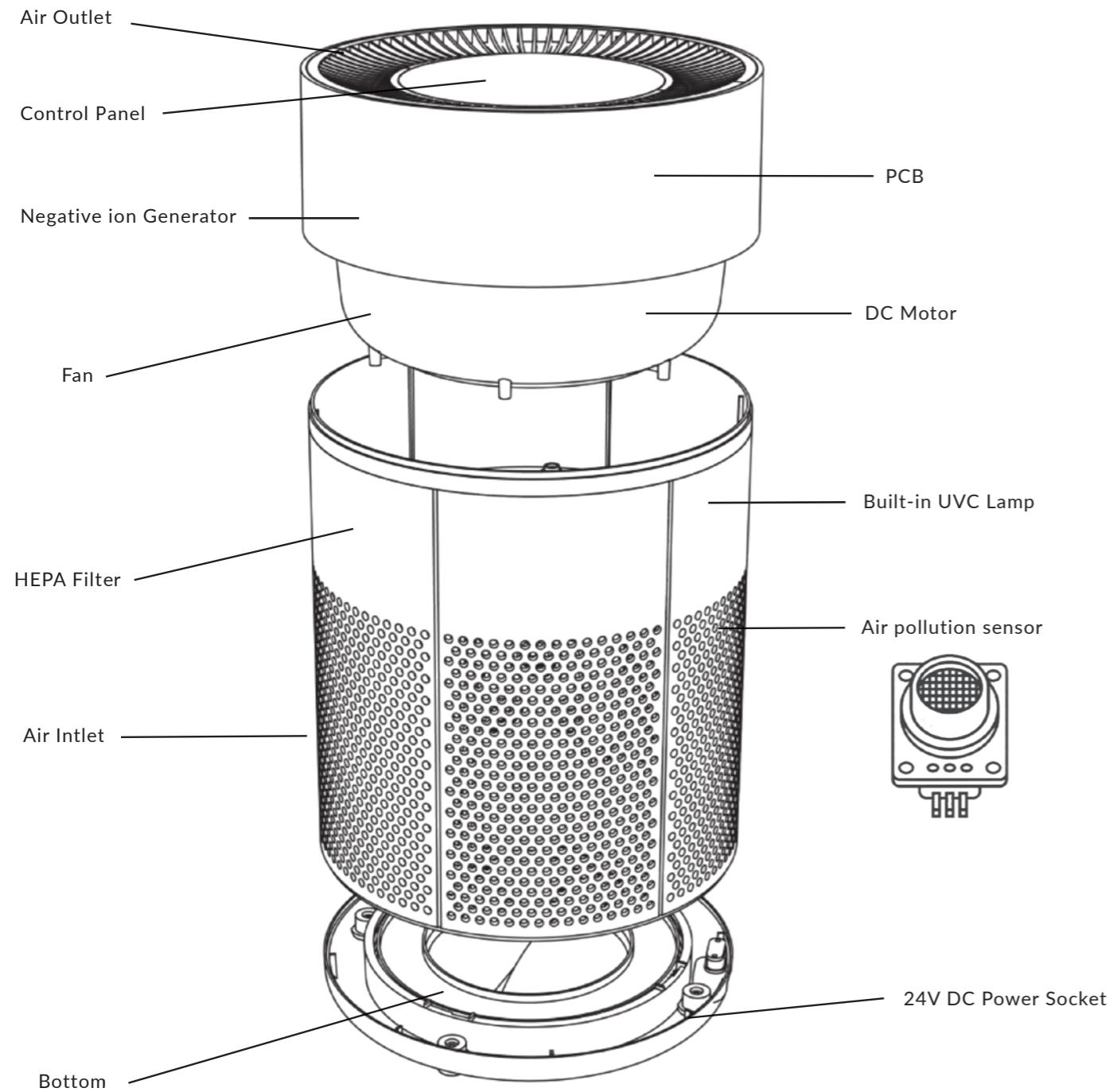

5-STAGE FILTRATION SYSTEM

- Multiple stage filtration with three filters.
- Contains UVC Light.

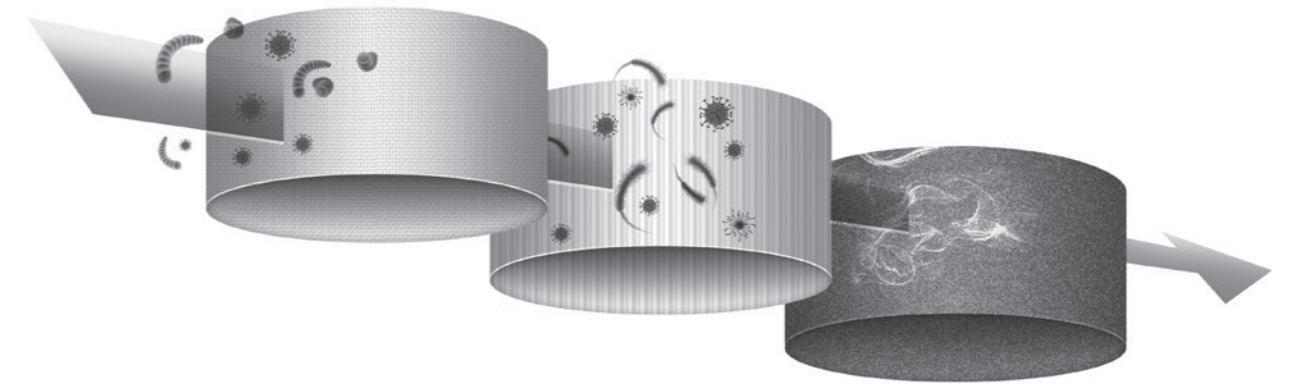





PREPARATION BEFORE USE

1. Open the package, take out the main unit and filter, remove the packaging bag, rotate the filter according to the direction of the logo and tighten the filter clip.
2. In order to better utilize the performance of the air purifier, the main air inlet should keep a certain distance from the obstruction, it is recommended to be more than 15cm.
3. Remove the power adapter and connect the power supply to the purifier socket. After power on, it will sound "drop" and the ON/OFF button is light.

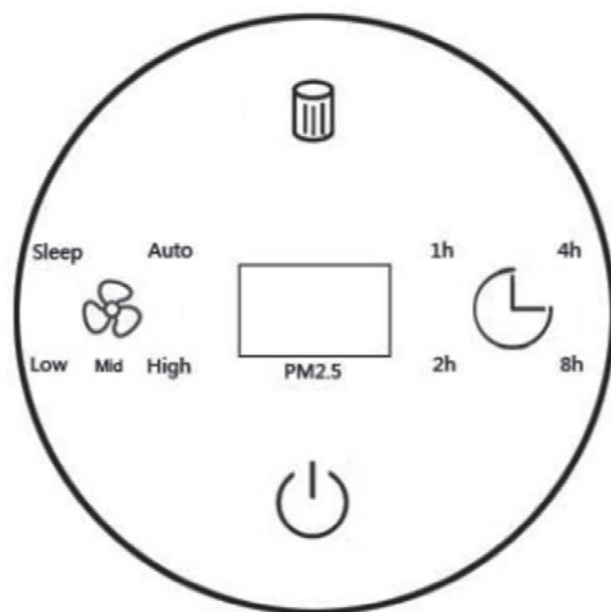
OPERATION PANEL AND FUNCTION

1. Control panel



	Power ON/OFF
	Timing adjustment: 1H-2H-3H-4H-5H-6H-7H-8H
	Fan speed adjustment: "Low-Mid-High-Sleep-Auto"
	Filter replacement reminder and reset

2. Standby

Insert the plug of air purifier into power source, the buzzer will ring, "powerbutton" indicator lights up.

3. Power On/Off

Tap the top power icon to switch the power on/off. The default fan speed will operate on Low mode, and the negative ion and UVC lamp will be working.

4. PM2.5 Display

The air quality sensor automatically starts working after the power is turned on. Wait 3 minutes for the sensor to stabilize. (Note: the value indicated in this function is for reference only and cannot be used to replace professional testing equipment).

5. Fan Speed button

Fan speed adjustment "Low" → "Mid" → "High" → "Sleep" → "AUTO", Loop in turn.

6. Timing Function

Touch the timing icon adjust the countdown shutdown time 1H-2H-3H-4H-5H-6H-7H-8H Loop in turn.

7. Replace the filter

When the air purifier is turned on, it will countdown, then the air purifier will turn off and back on. It will then continue to countdown. When the filter in place has been in use for 3000 hours, the replacement filter indicator light will turn red. Replace the old filter with the new one, and then press the filter reset icon for 3-5 seconds; the icon will light up and stay lit in white.

INSTRUCTIONS

Before you turn on the machine for the first time, be sure to remove the filter bag before you use it.

1. Air purifier filter installation

Grasp the bottom cover handle by hand (the position shown by the picture) and turn the bottom cover in the direction of unlocking. Then take out the filter, remove the filter bag, and put the filters back, then insert the bottom cover into the fuselage and turn it in the direction of the lock.

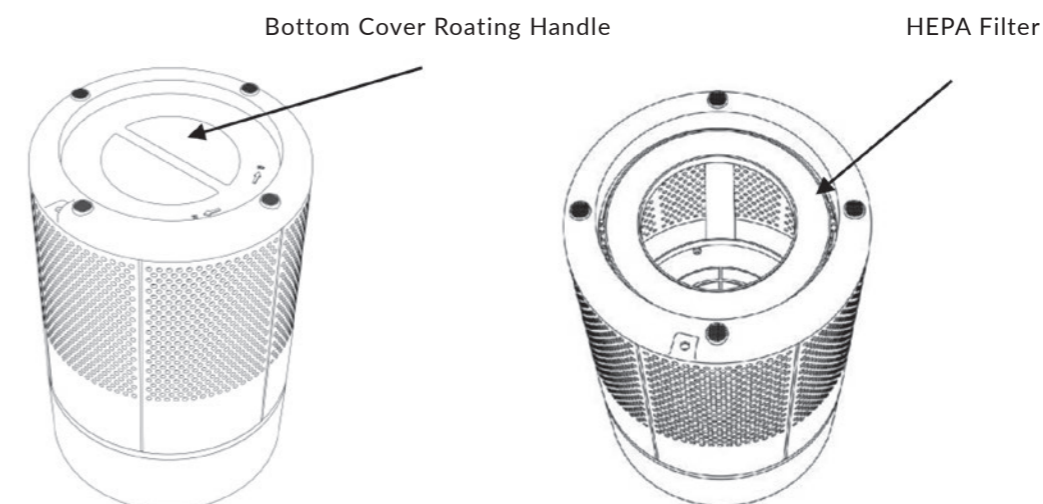

2. Air Quality Indicator

Air Quality	Good	Lightly Polluted	Heavily Polluted
Fan Speed	Low	Mid	High
PM2.5	0-50	51-149	>150

3. The Sleep Mode

The lights of the other icons on the sensor panel are off, and the purifier will automatically set itself to the low fan speed.

4. Filter Replacement (After 8-12 Months of Use)

1. Make sure the air purifier is unplugged before opening the filter cover at the bottom.

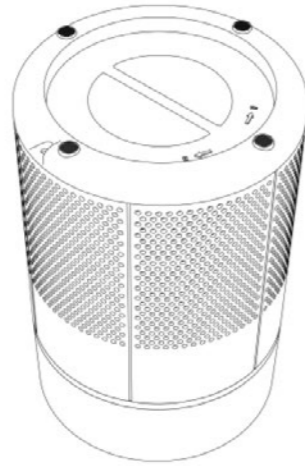

2. Open the filter cover by turning it counter-clockwise.

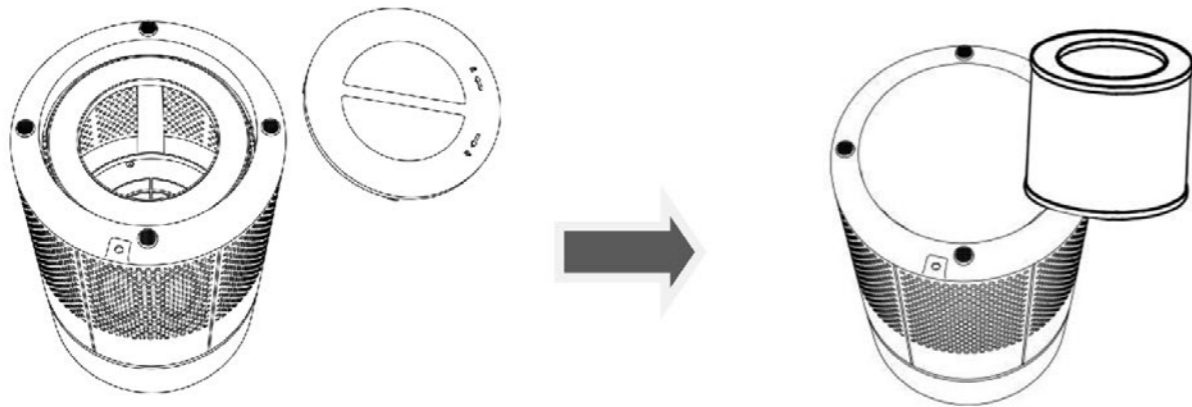

3. After replacing the filter, lock the filter cover by turning it clockwise.

MAINTENANCE

⚠ Be sure to unplug the power adapter before performing any maintenance.

1. Clean the filter once a month. The surface of the filter should only be cleaned with a brush or a dry cotton cloth. Do not wash the filter with water or detergent. The filter can easily break or become deformed. Do not press hard when cleaning. If the filter gets damaged, make sure to replace it with a new one.
2. Replace the filter once every 8-12 months. Depending on the place and the method of use, such as heavily polluted areas, smoking by family members, etc., the filter replacement cycle may be shortened. Please replace the filter in time when the filtering effect is no longer effective.
3. Outer surface cleaning: Wipe the outer surface and air inlet and outlet with a soft cloth. Do not use chemical cleaner.
4. If left idle for a long period of time, make sure to unplug the power adapter, clean the outer surface and the filter. Cover the air purifier with a plastic bag and store it in a room with low moisture levels.

PRODUCT SPECIFICATIONS

Product Name:	Air Purifier
Product Size:	208x208x323mm
Packing Size:	246x246 x405mm
Product Weight:	1.8KG
HEPA Filter:	H13 level
Application Area:	≤25m ²
UVC type:	Cold Cathode UVC tube

Negative ions:	5millions/cm ³
Adapter Voltage:	100-240V 50/60Hz
Rated Voltage:	24V DC
Rated Power:	22W
CADR Particles	150(m ³ /h)
Noise:	≤55 dB(A)
Product NO:	MT-AIRPURIF-001

PRECAUTIONS

1. Do not use liquid to clean this product.
2. There is a high speed wind wheel in the purifier. Do not put your hands or foreign objects into the air inlet and outlet.
3. Place the purifier as far as possible out of reach of children. Do not give this product to children.
4. In order to improve the purification effect, try to close the doors and windows when using the product.
5. Do not use power adapters of different specifications. Please install the power adapter supplied with this product.
6. Do not use this purifier in the bathroom or other places with high temperature, humidity and water.

CAUTION: Do NOT use this air purifier in any space that may have carbon monoxide or another gas present. Always air out enclosed spaces and have working carbon monoxide detectors prior to use.

TROUBLE SHOOTING

Phenomenon	Possible Reasons and Solutions
Odor	The filter is too dirty and has not been replaced for a long time replace the filter.
	The filter is flooded or used in a wet environment replace the filter.
	Re use after a period of storage clean the filter, if not, replace the filter.
	If there is burnt smell immediately stop using, unplug the power supply, contact repair.
No wind at the outlet	The motor is not running check if the power supply is normal, replace the power ad aptor or contact repair.
No effect	Filter failure replace the filter.
	Used in inappropriate places (large area).
Air purifier is too loud	The fan speed level is too high. The noise you might hear coming from your air purifier is produced by the operation of the motor and the fan. The air purifier has been designed to minimize noise but in some situations (such as when trying to sleep or in a silent room) you may hear it. If this is the case, please change the fan speed to lower level or to sleep mode
	When on auto mode, the Air Purifier uses sensors to detect invisible changes in the air and adjusts the fan speed to restore quality as quickly as possible. To reduce the noise level of the device, you can adjust the fan speed or switch on sleep mode.
Display "ERR"	Replace air pollution sensor. Turn off the purifier, open the bottom cover, take out the filter element, the position for the sensor is as shown in the product picture, use a Philips head screwdriver to unscrew the sensor and replace it with a new one.

LIMITED LIFETIME WARRANTY

Your Medic Therapeutics Air Purifier is backed by a limited lifetime manufacturer's warranty. Medic Therapeutics will repair or replace your device at any time should it fail due to a defect in material or workmanship, subject to the certain limitations.

This limited warranty does not cover any damage that results from unauthorized or improper use, service, or repair. Further, it does not cover damage caused by accident, impact, negligence, or normal wear and tear. Should you discover your Medic Therapeutics Air Purifier is not functioning properly, please send your device to our repair center for evaluation. If your product cannot be repaired or serviced we will reserve the right to change it for a similar or newer model.

Please note that a flat rate of \$35.00 will be charged to cover a service evaluation fee and return shipping of your device. All warranty claims must be accompanied by a copy of your proof of purchase from an authorized retailer. Please send your device, proof of purchase, and a check or money order in the amount of \$35.00 made out to Medic Therapeutics to:

Medic Therapeutics Service Center
3069 Taft Street
Hollywood, FL 33009

the warranty fee is \$35.00 for the regular Air Purifier and \$66.00 for the Mini Air Purifier.

EPA Est.: 97483-CHN-1

Imported By: Medic Therapeutics | 3069 Taft Street | Hollywood, FL 33021