

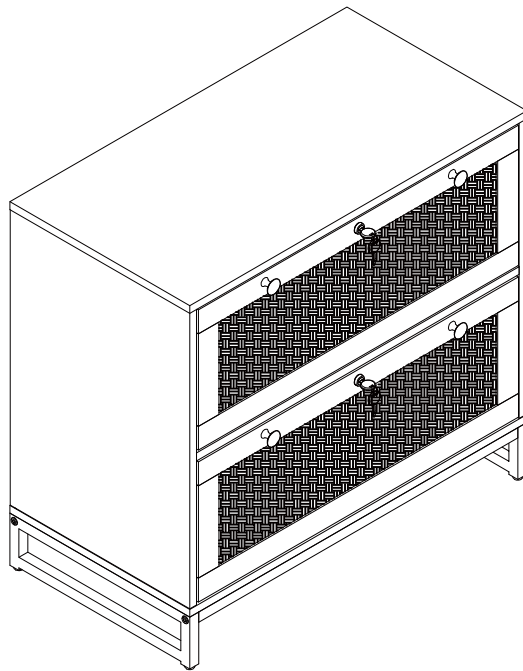

# VINGLI FILE CABINET

ASSEMBLY INSTRUCTION FOR MODELS: FC0WRLO/FC0W2LB/FC0W2LW



2PERS

Tool Required Not Provided

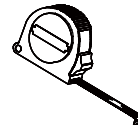
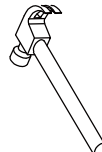
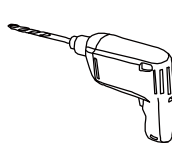
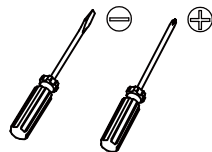

Thank you for purchasing from VINGLI!

Please contact us via email if parts are missing or damaged, we will gladly ship your replacement parts free of charge. Please attach your Order ID so that we can assist you better.

✉ EMAIL

🌐 WEBSITE

⚠ IMPORTANT

[support@vingli.com](mailto:support@vingli.com)

[www.vingli.com](http://www.vingli.com)

THIS INSTRUCTION BOOKLET CONTAINS IMPORTANT SAFETY INFORMATION. PLEASE READ AND KEEP FOR FUTURE REFERENCE.

# CONTENT

1. Return & Warranty.....	1
2. Before Starting.....	2
3. Model & Assembly Tips.....	3
4. Identify Parts.....	4
5. Part List.....	5
6. Assembly Steps.....	7
7. Options Of File Storage.....	35
8. FAQs.....	36
9. Supplementary Instruction for Safe Use.....	37

# RETURN & WARRANTY

## Thank you for choosing our product!

We would like to take this opportunity to thank you for choosing VINGLI.

We hope that you are completely satisfied with your purchase, and enjoy it for years to come.

**Your satisfaction is our highest pursuit.**

## Return policy

VINGLI believes you will absolutely love your file cabinet, but if for some reason you want to return the product, please contact us directly before you decide to return your product to the retailer. Our Customer Service organization can answer most concerns and can assist you with any questions you may have about your new product.

The item must be returned in good condition, in original box, with all original proof of purchase, parts and accessories, within the time frame specified by the retailer it was purchased from.

## Warranty

VINGLI warrants this product to be free from defects in material and workmanship agrees to remedy any such defect. This warranty covers one year from the date of original purchase. This is solely limited to be repair or replacement of defective parts and no assembly labor is included.

This warranty does not apply to any product which has been improperly assembled, subjected to misuse or abuse or which has been altered or repaired in any way.

Components repaired or replaced warranted through the remainder of the original warranty period only. The defective components will be repaired or replaced without charge, subject to the terms and conditions described above.

For help with assembly, identifying parts, product information or to order parts, please contact us freely.

# BEFORE STARTING

## Before Using Product



- Read each step carefully before starting. It is very important that each step is performed in the correct order. If these steps are not followed in sequence, assembly difficulties will occur.



- Make sure all parts are included



- Recommended # of people needed for assembly: 2  
Estimated assembly time is 4 hours by electric screwdriver.



- Work in a spacious area and near where the unit will be used, preferably on a carpet, or use a piece of the cardboard packaging to protect your floor and product.



- For a smooth assembly process, we suggest you keep a lite tightness for all the screws during assembly. After the whole product is assembled, firmly tighten all the screws.

## WARNING

-Do not allow children to climb on unit.

-Avoid sharp objects or corrosive chemicals to prevent damage to the product.

-During assembly, keep parts and packaging materials away from children and pets as there could be potential injury and choking hazards.

-Please make sure that all objects are removed before moving the assembled unit.

-The unit must be team lifted, not dragged or pushed. Failure to do so could cause instability, product collapse, and/or serious injury.

# MODEL & ASSEMBLY TIPS

## Applicable Model

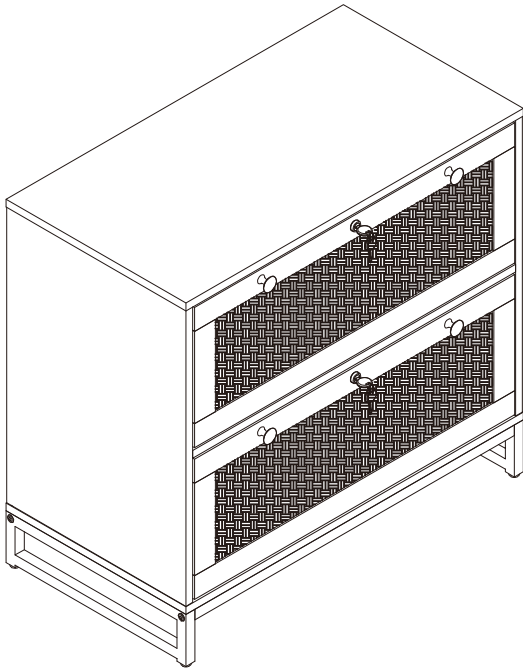

### OVERALL SIZE:

29.52"W x 15.7D"x27.55"H  
75cmx40cmx70cm(LXWXH)

### FEATURES:

- Lateral File Cabinet W/ Lock (Letter/A4/Legal Size)
- Anti-tipping Device
- Home Office Style

### MAXIMUM LOAD:

DRAWER BOTTOM: 88 LBS  
HANGING ROD: 44 LBS

Estimated Time for Assembly



**240mins with an electric screwdriver**

## Caution:

1. This product is designed for home use and not intended for commercial use.
2. This product contains small components. Please ensure that they are kept away from small children.
3. Be careful when using power tools to assemble your furniture. Power tools may strip or damage the parts.

# IDENTIFY PARTS

1 case shipment

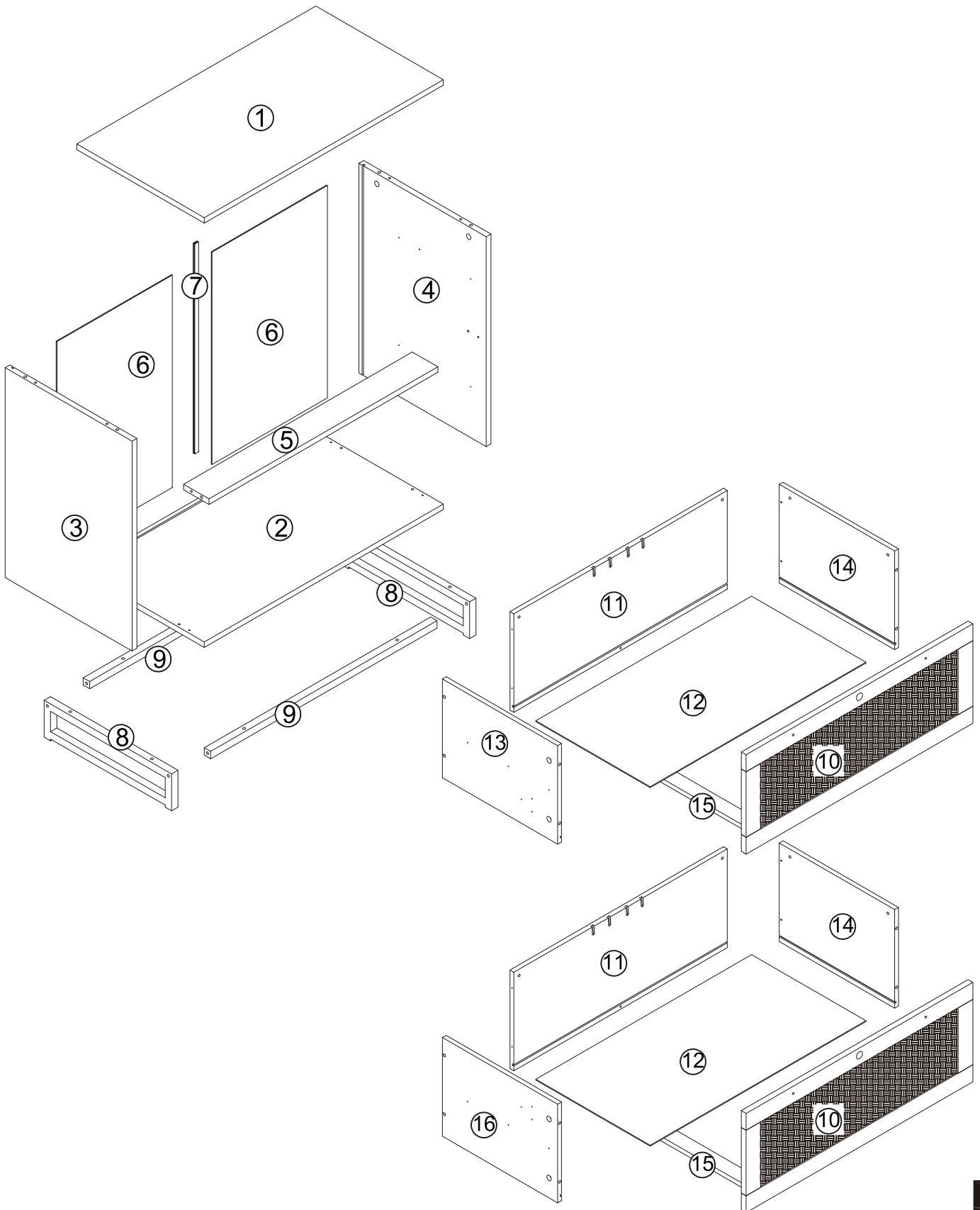

# PART LIST

1 x1

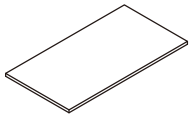

Top Panel

2 x1



Bottom Panel

3 x1

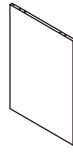

Left Panel

4 x1

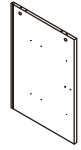

Right Panel

5 x1

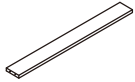

Brace

6 x2



Back Panel

7 x1



Back Connecting Strip

8 x2



Iron Side Frame

9 x2

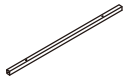

Iron Brace

10 x2

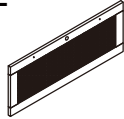

Drawer Front Panel

11 x2



Drawr Back Panel

12 x2

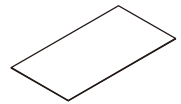

Drawer Bottom Panel

13 x1



Upper Dawer Left Panel

14 x2



Drawer Right Panel

15 x2



Drawer Support Panel

16 x1



Lower Drawer Left Panel

# PART LIST

Ax16(+1)

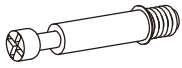

6x35mm

Cam Bolt

Bx16(+1)



15x10mm

Cam Lock

Cx10(+1)



6x30mm

Wood Dowel

Dx16(+1)



4x35mm

Wood Dowel

Ex1

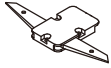

Anti-Tipping Device

Fx4

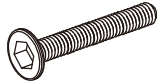

M6x40mm

Screw

Gx8

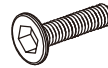

M6x30mm

Screw

Hx30(+3)



3.5x12mm

Screw

Ix4

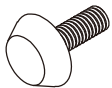

Adjustable Leveler

Jx4



Drawer Slide

Kx1



M4

Hexagon Wrench

Lx8

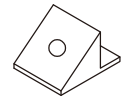

Mending Wedge

Mx2



Anti-tipping Belt

Nx2

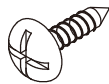

Screw

Ox8



3x16mm

Screw

Px4



Round Handle Screw

Qx2

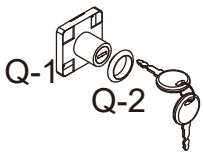

File Lock

Rx11(+1)



3.5x16mm

Screw

Sx2



Anti-Tipping Device

Ux4



Long Hanging Rod

Vx8



Short Hanging Rod

Wx2

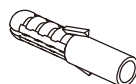

6x30mm

Expansion Screw

Xx2



Washer



# ASSEMBLY STEPS

Detach the drawer slide before assembling it, there is a detach button on the side of the drawer slide and you can remove the drawer slide by pressing the button down

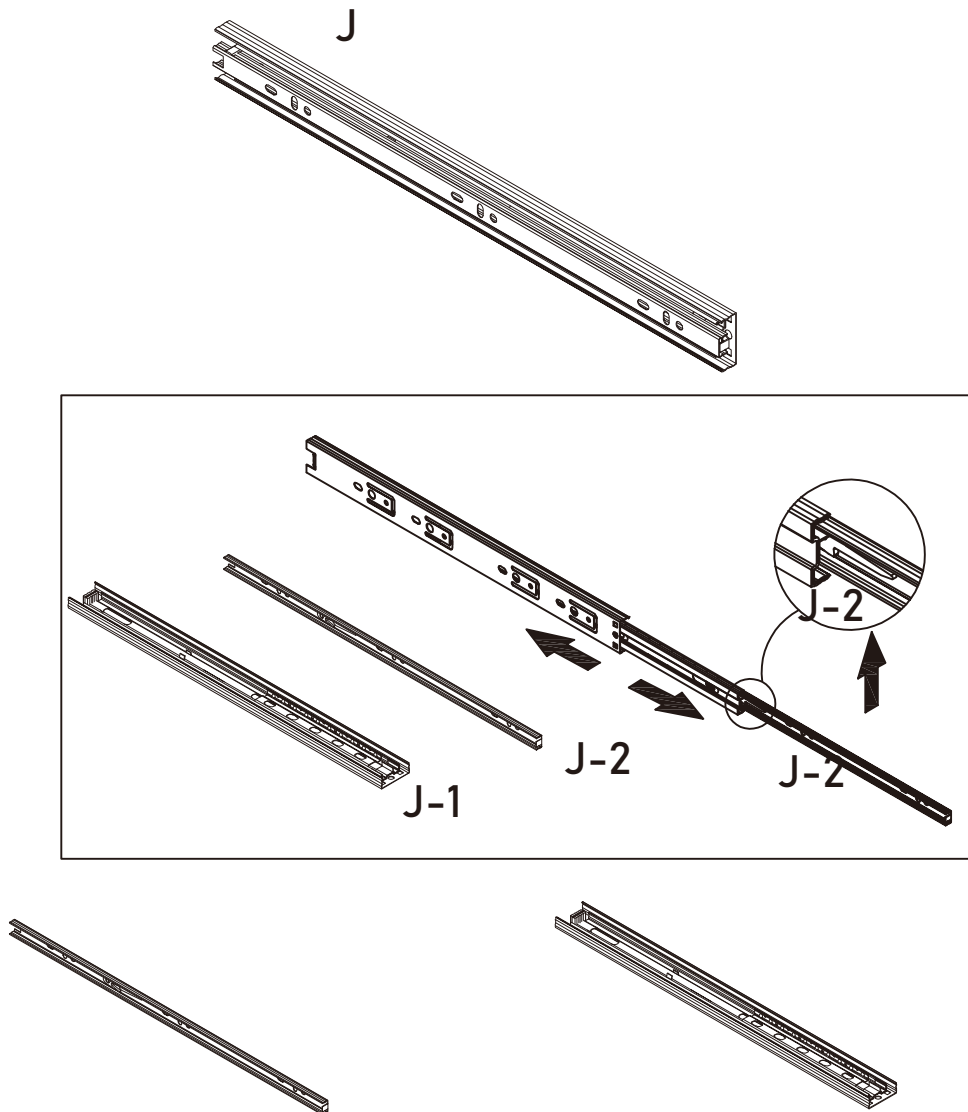

Guide to assemble the Cam Bolt and Cam Lock. Note to align the arrow of the Cam Lock with the direction of the head of the Cam Bolt, and rotate the Cam Lock until it is locked

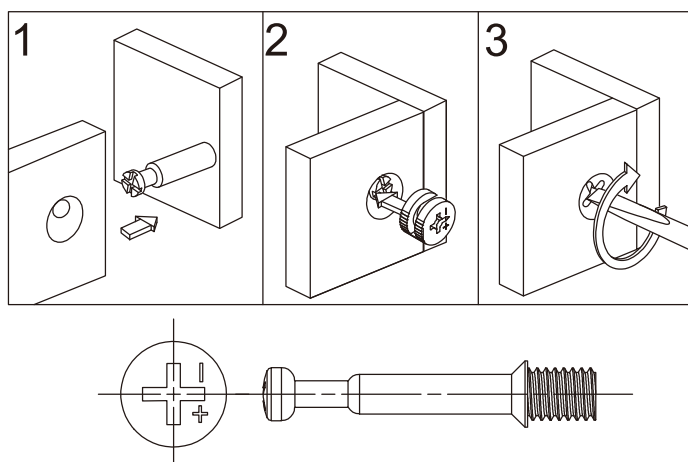

# ASSEMBLY STEPS

**STEP 1** Kind Tips: The pre-drilled holes for locating the drawer slides are relatively small, look carefully. Please don't worry, they are there

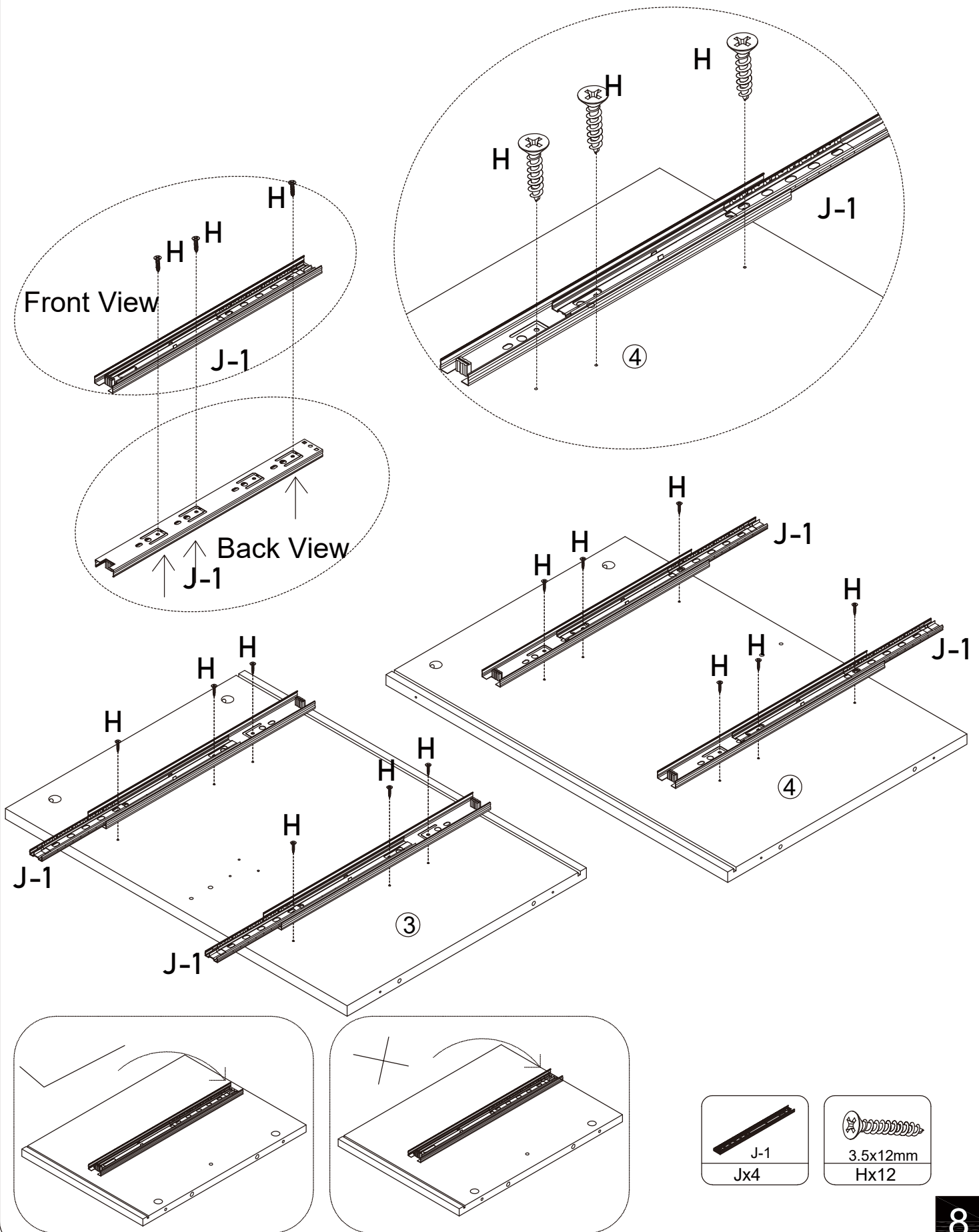

# ASSEMBLY STEPS

**STEP 2** Fix the Anti-Tipping Device(E) on Panel #3 with Screws(R)

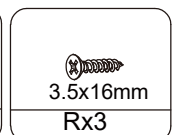
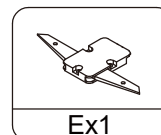
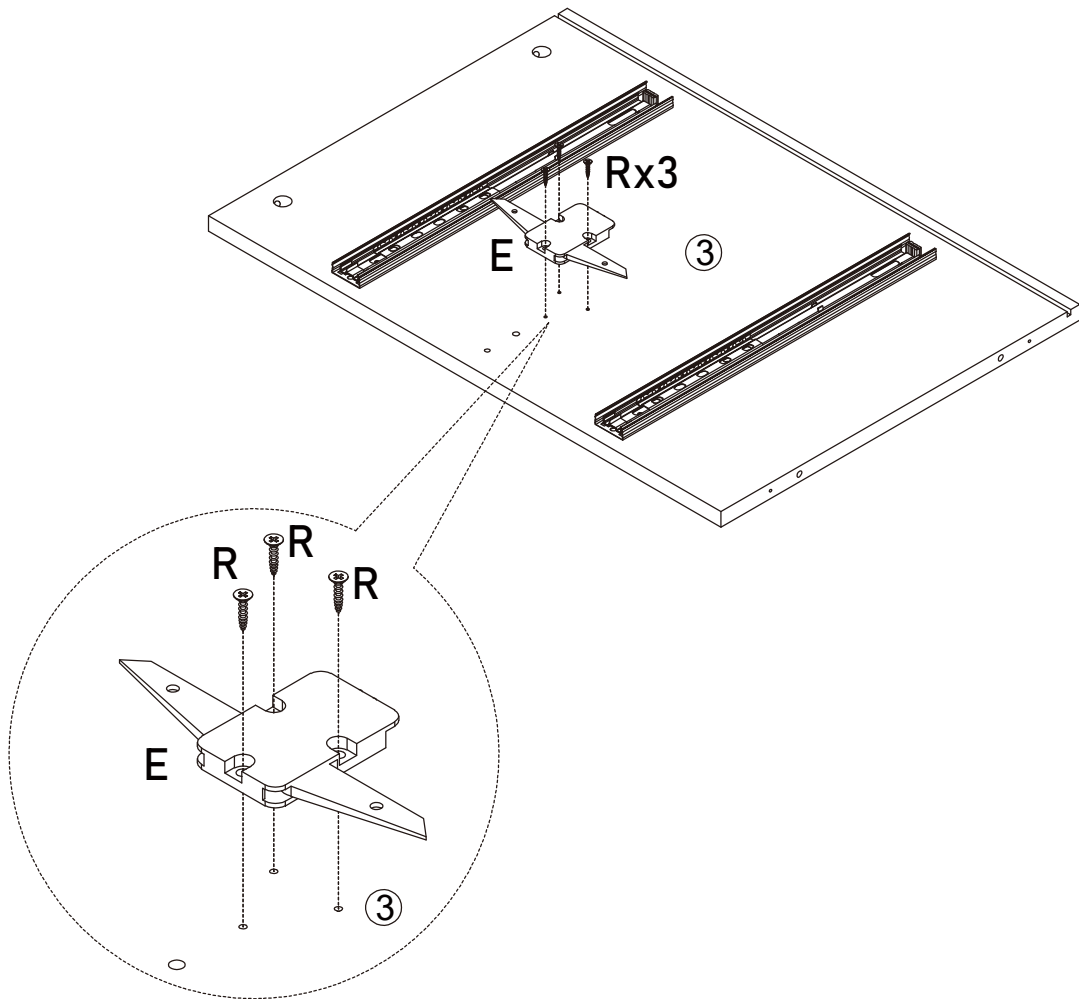

# ASSEMBLY STEPS

**STEP 3** Screw the cam bolt (A) onto the panels # 1, # 3 and # 4

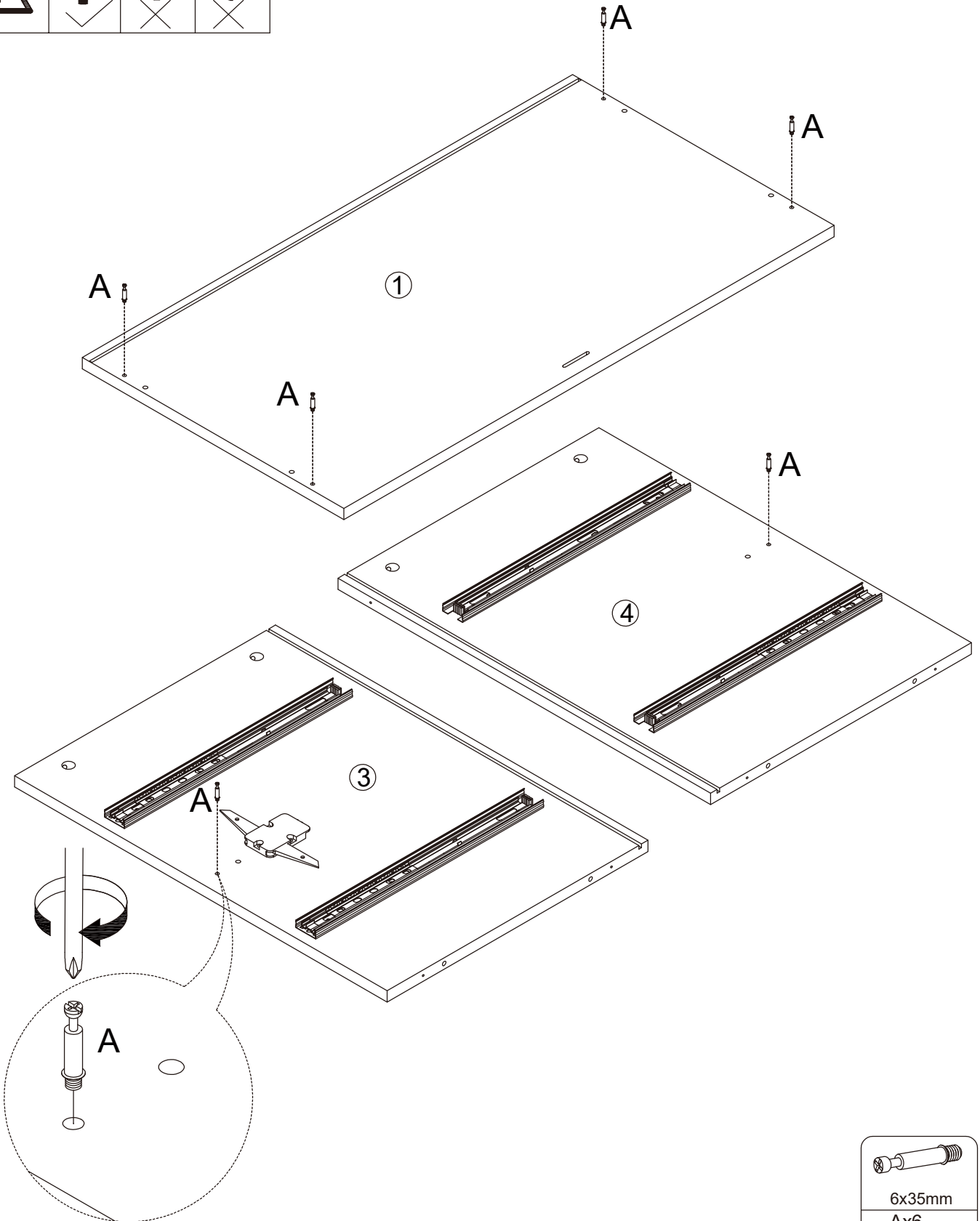
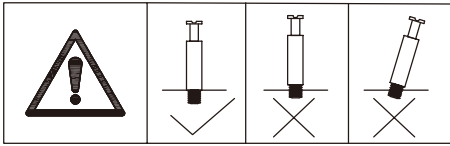

# ASSEMBLY STEPS

**STEP 4** Insert Wood Dowel(C) into Panel #5 first, and then connect Panel#4 to it with Cam Lock(B)

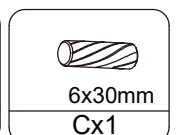
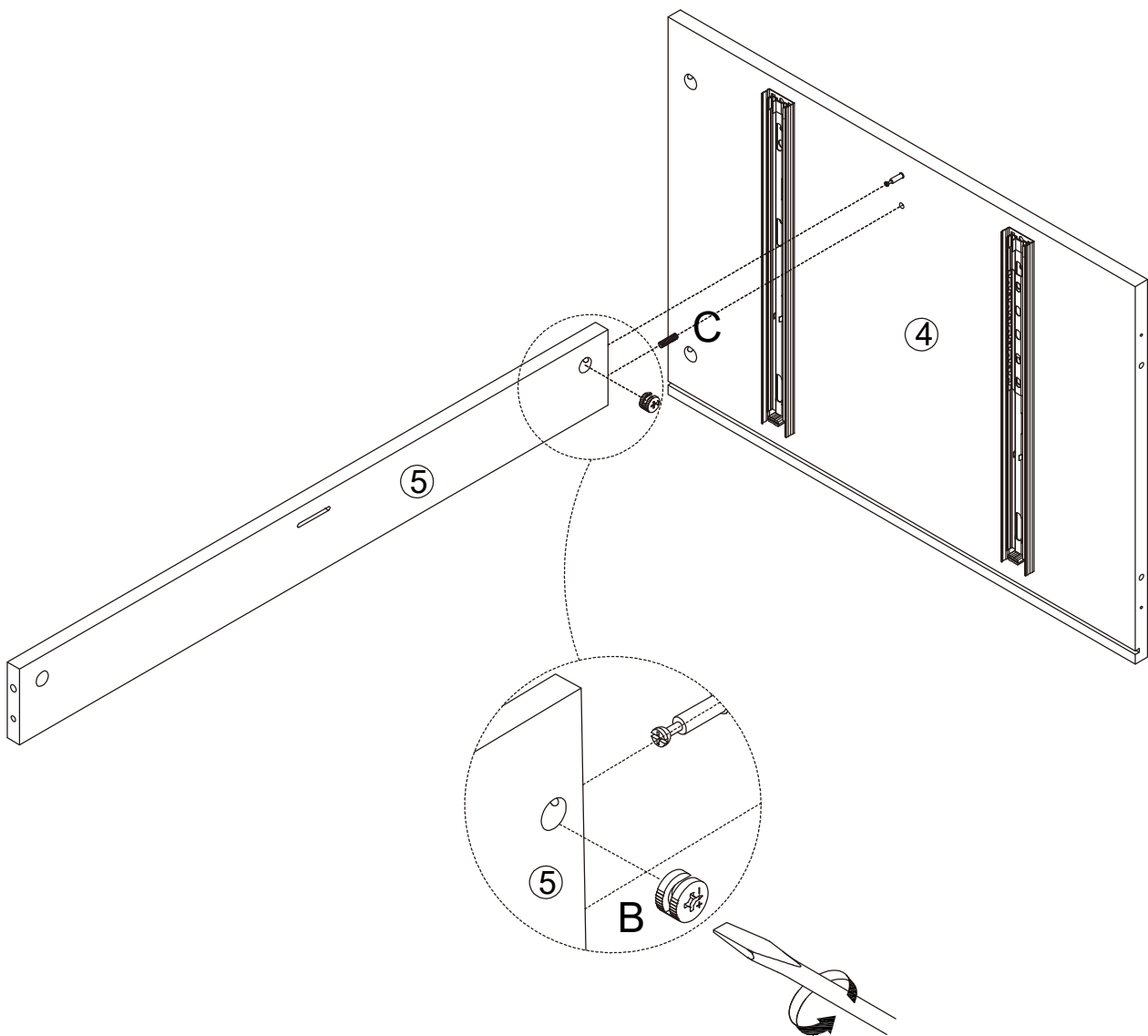

# ASSEMBLY STEPS

**STEP 5** Insert Wood Dowel(C) into Panel #5 first, and then connect Panel #3 to them with Cam Lock(B)

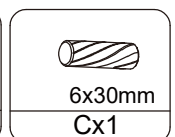
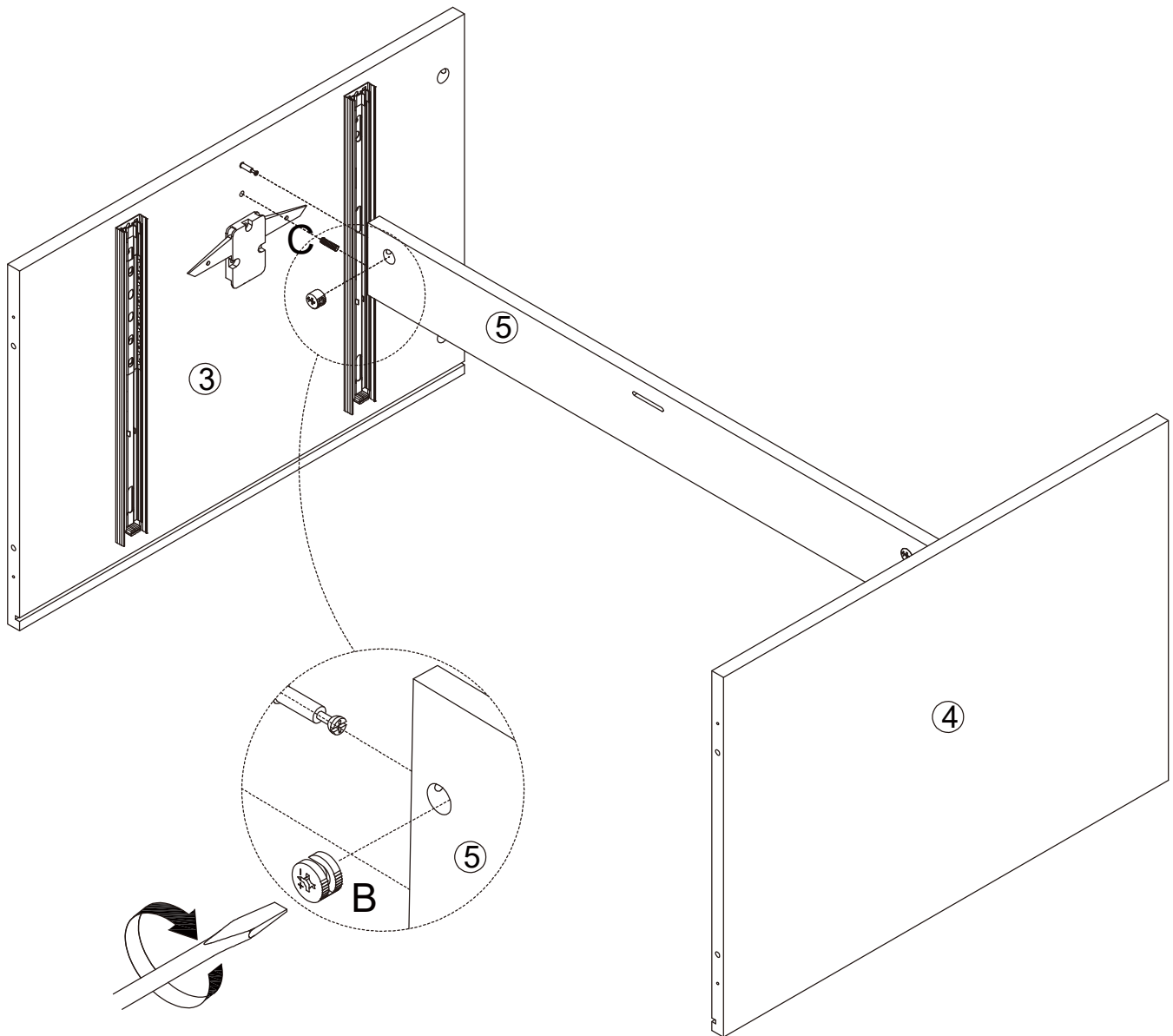

# ASSEMBLY STEPS

**STEP 6** Insert Wood Dowel(C) into Panel #3 #4 first, and then connect Panel #2 to them with Screw(D)

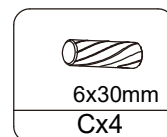
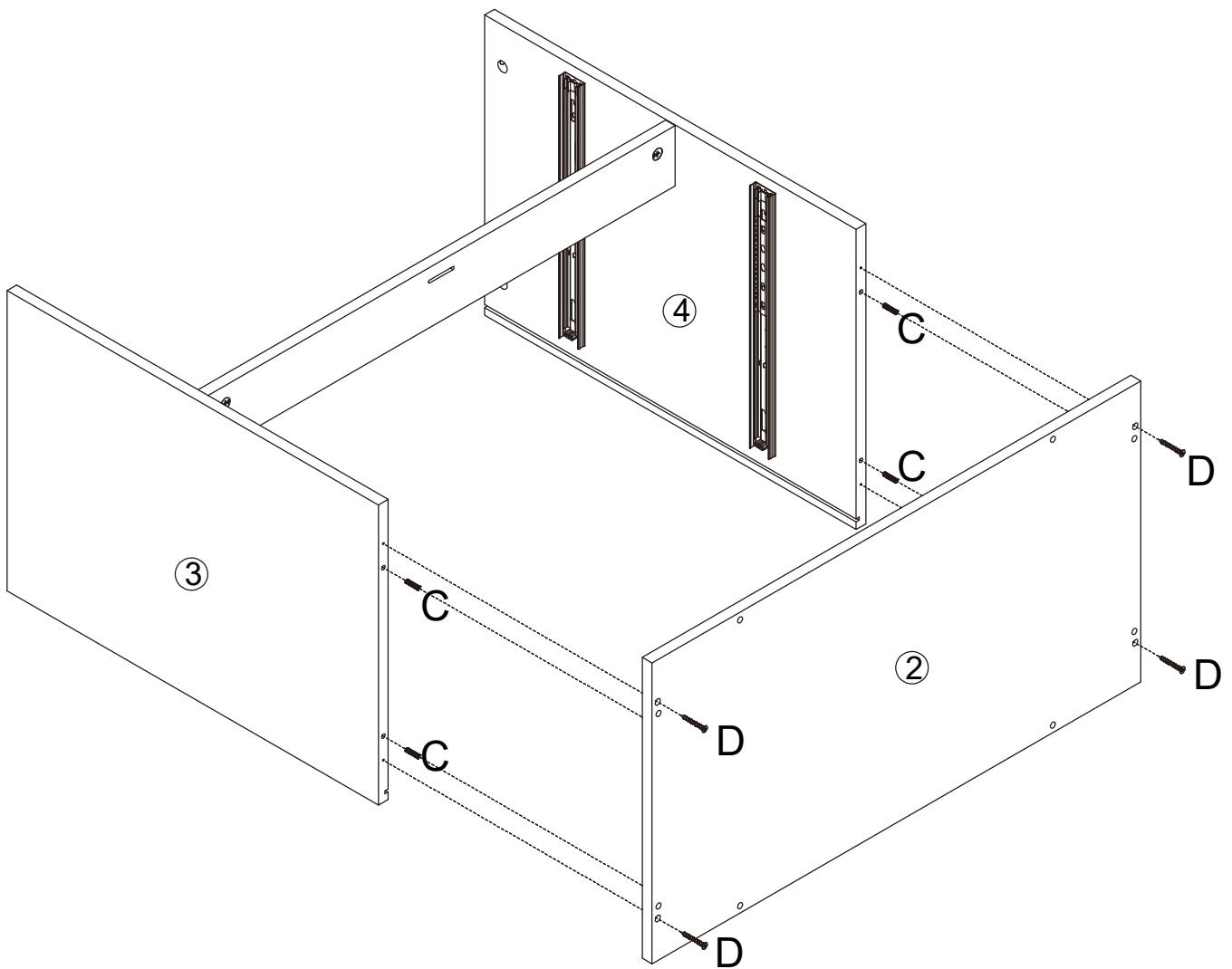

# ASSEMBLY STEPS

## STEP 7 Build the iron frame part

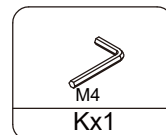
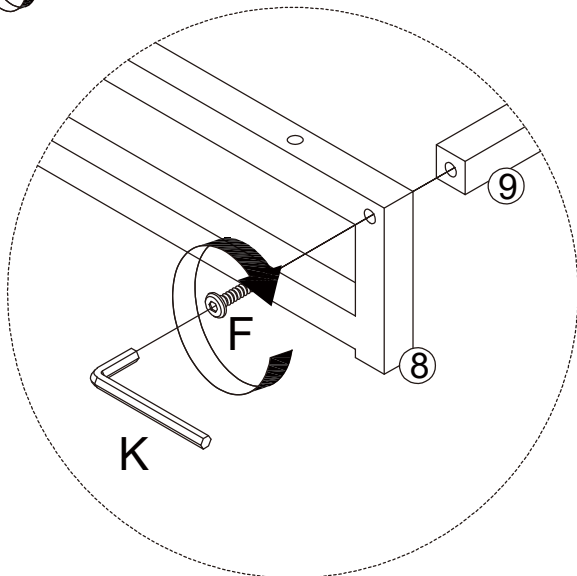
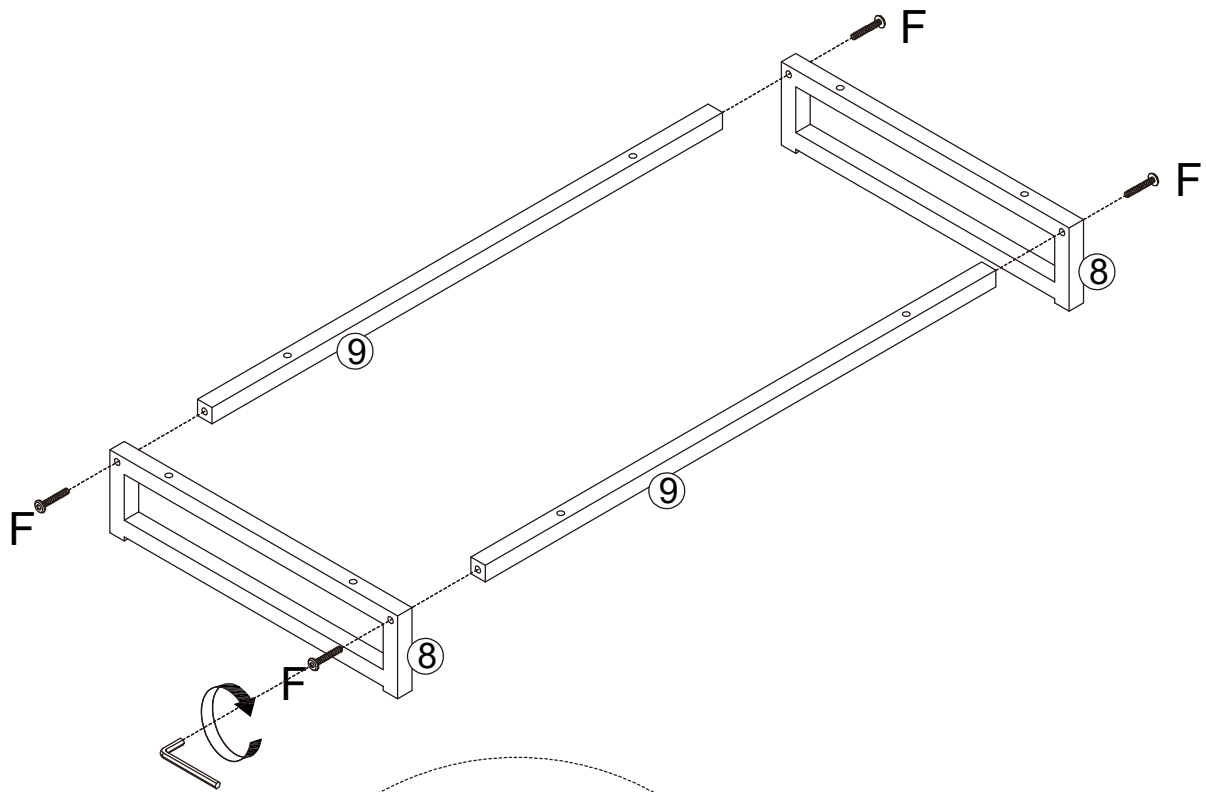



# ASSEMBLY STEPS

**STEP 8** Connect the iron frame part to Panel #2 with Screw(G)

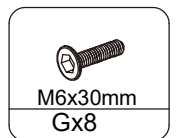
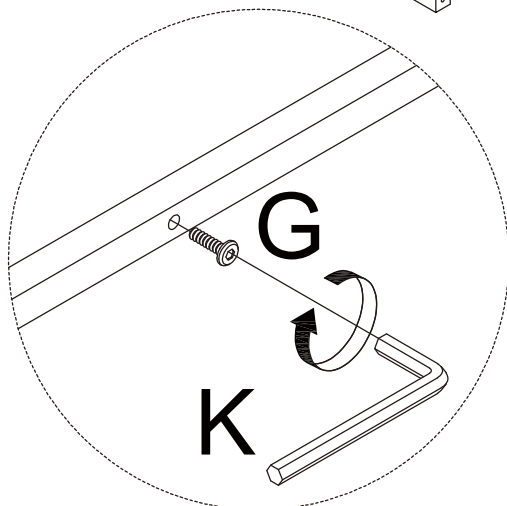
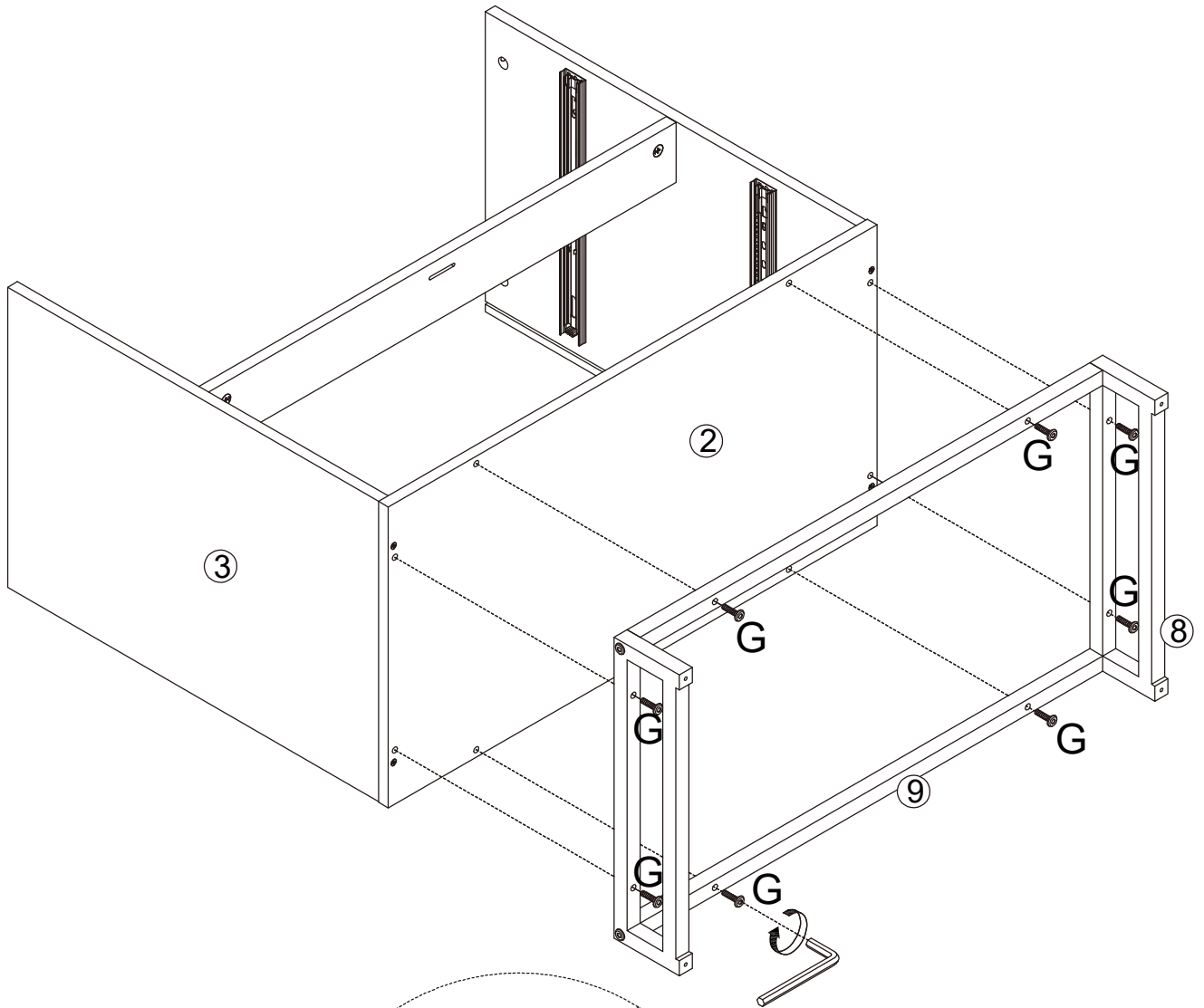

# ASSEMBLY STEPS

**STEP 9** Connect the Adjustable Levelers to the bottom

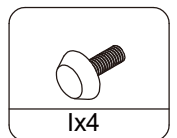
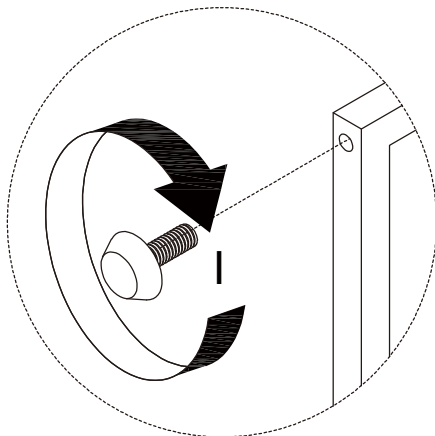
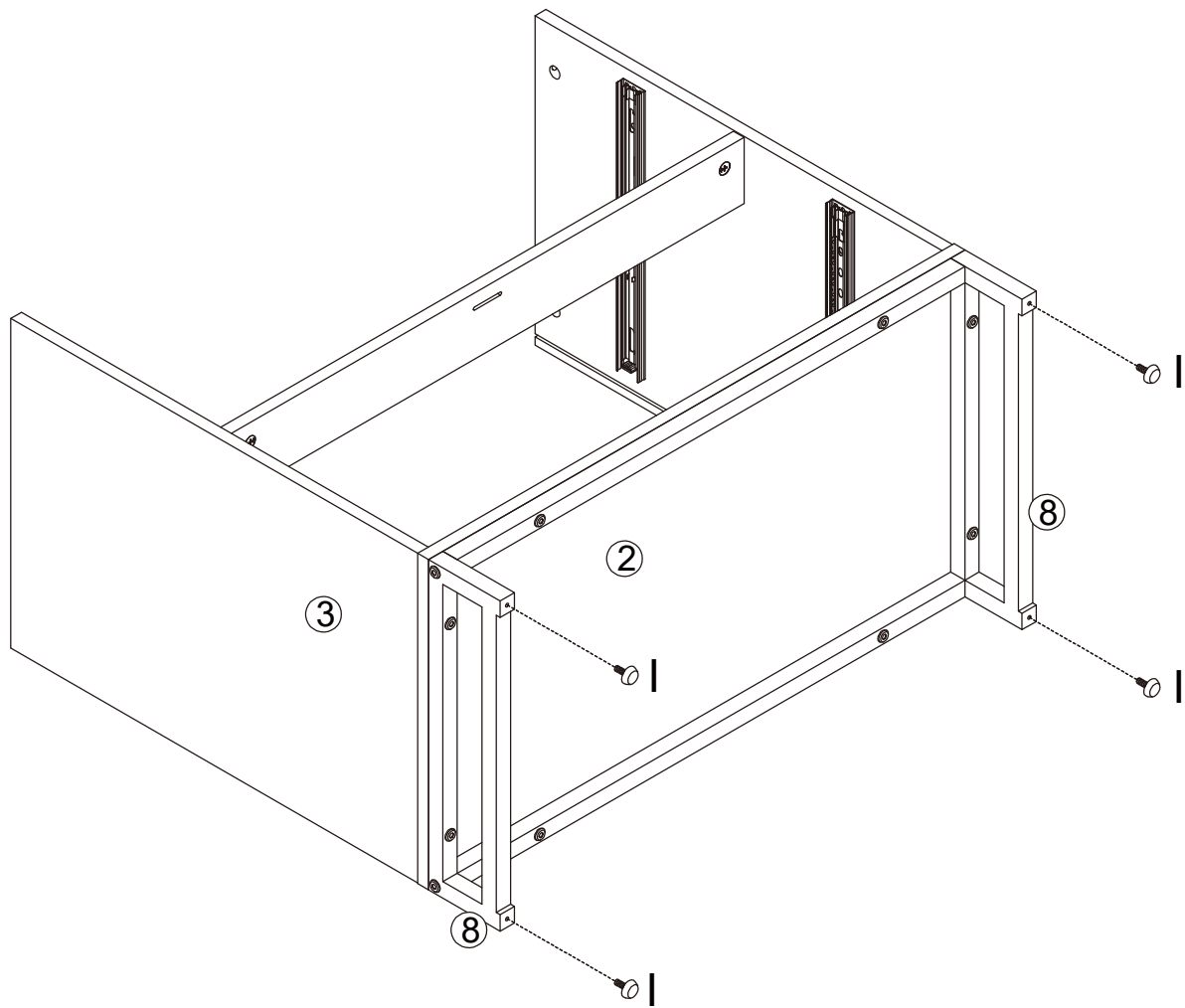

# ASSEMBLY STEPS

**STEP 10** First, clip two Panel #6 and Back Connecting Strip #7 together, and then push them in along the grooves on Panel #3 #4

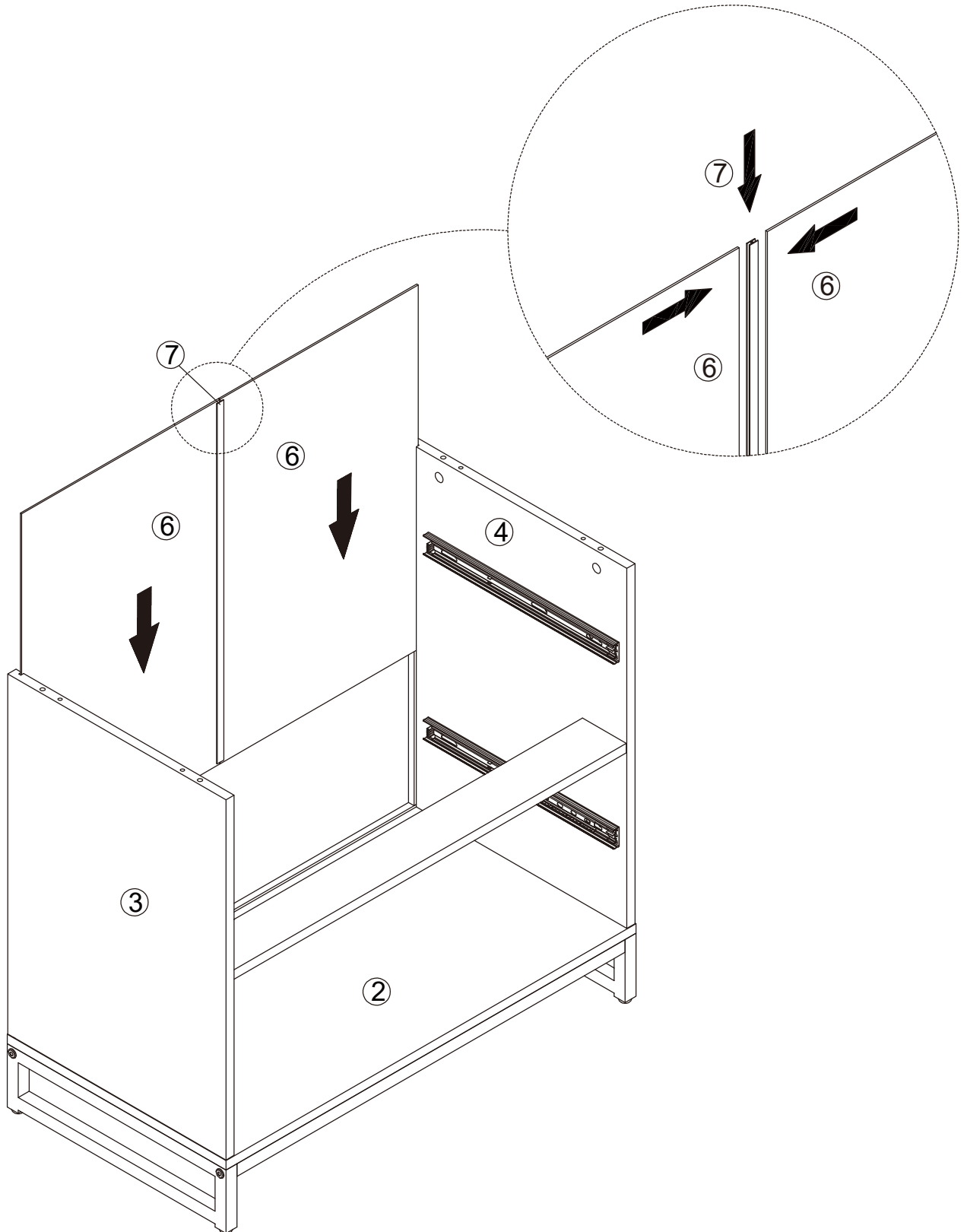

# ASSEMBLY STEPS

**STEP 11** Insert Wood Dowel(C) into the top of Panel #3 #4 first and then connect Panel #1 to the cabinet body with Cam Lock(B)

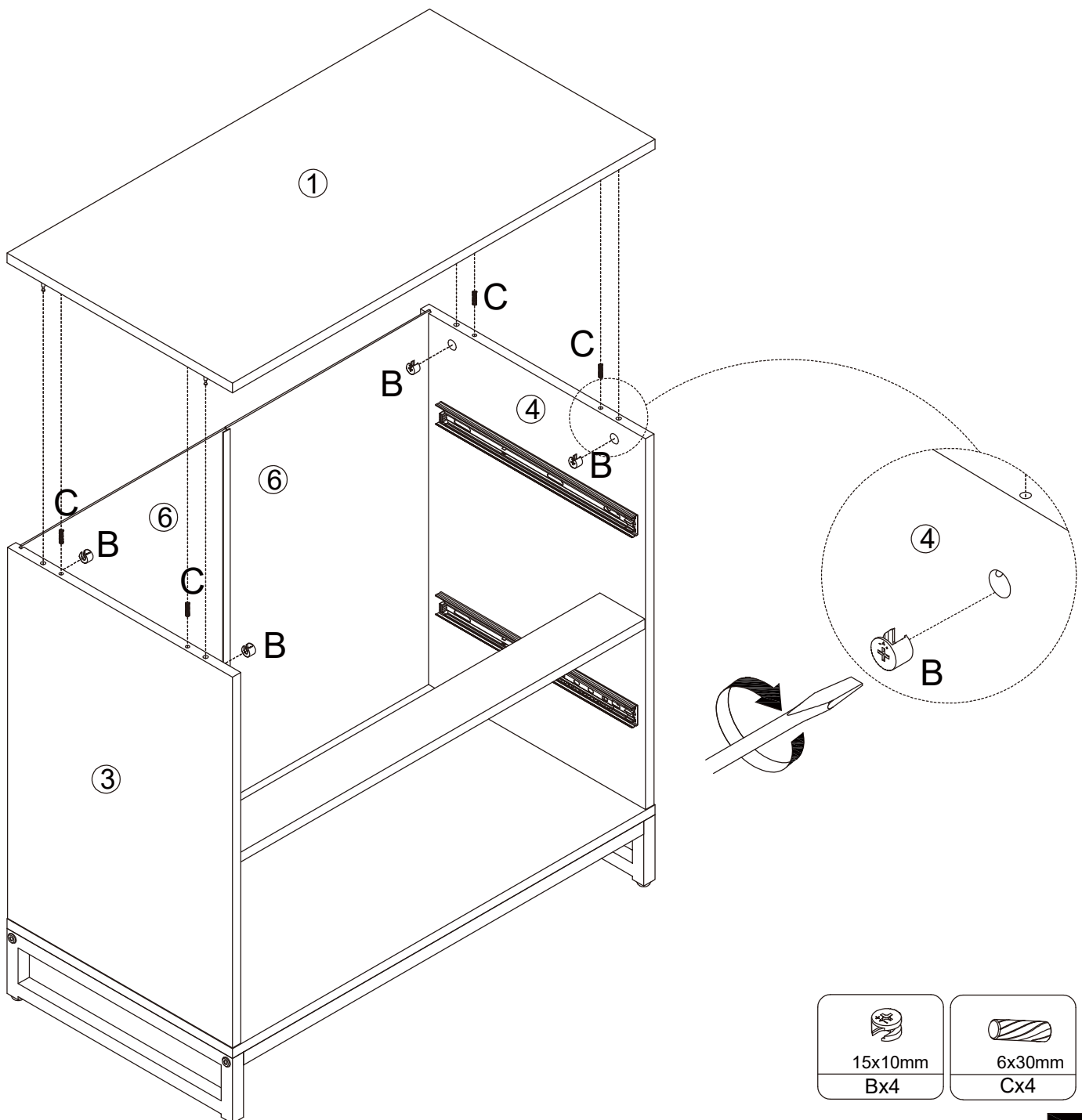

# ASSEMBLY STEPS

**STEP 12** Fix the Mending Wedge(L) with Screw(O) as picture shows for more stability  
Use screws (N) to fix the Anti-tipping Belt(M) to Panel #3 #4, and add Washer(X) in the middle

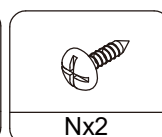
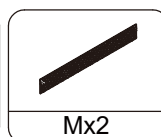
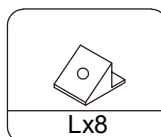
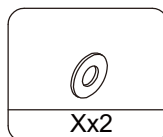
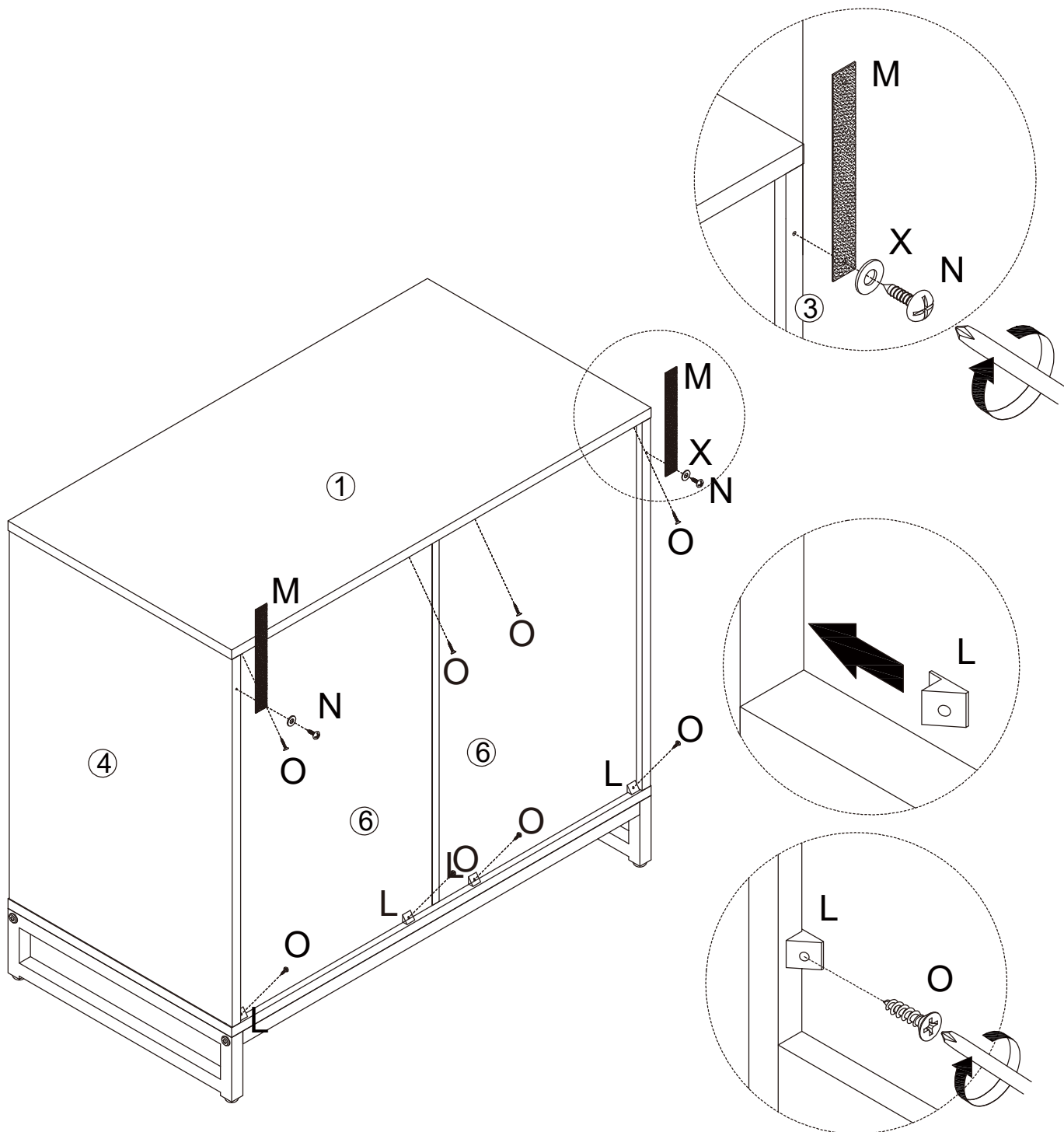

# ASSEMBLY STEPS

**STEP 13** Screw Cam Bolt(A) to Panel #10;  
Fix Lock and Handles to Panel #10 as picture shows

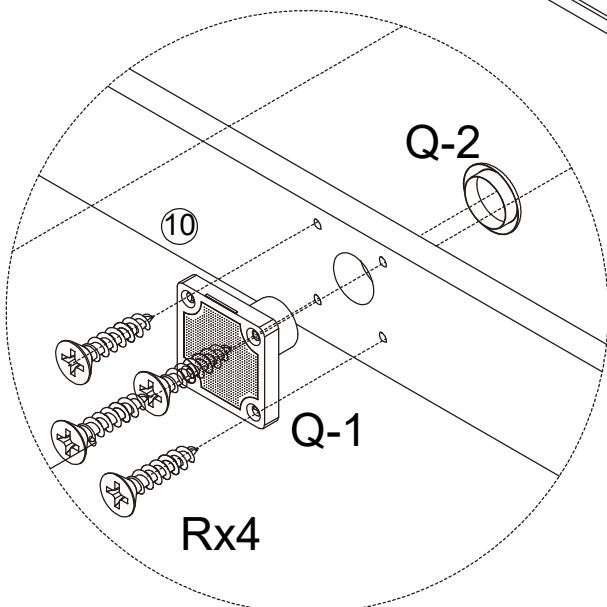
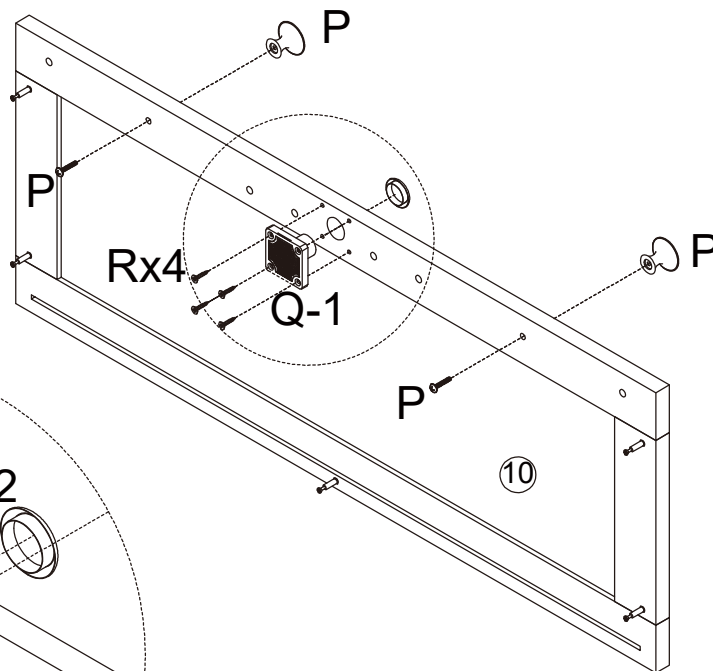
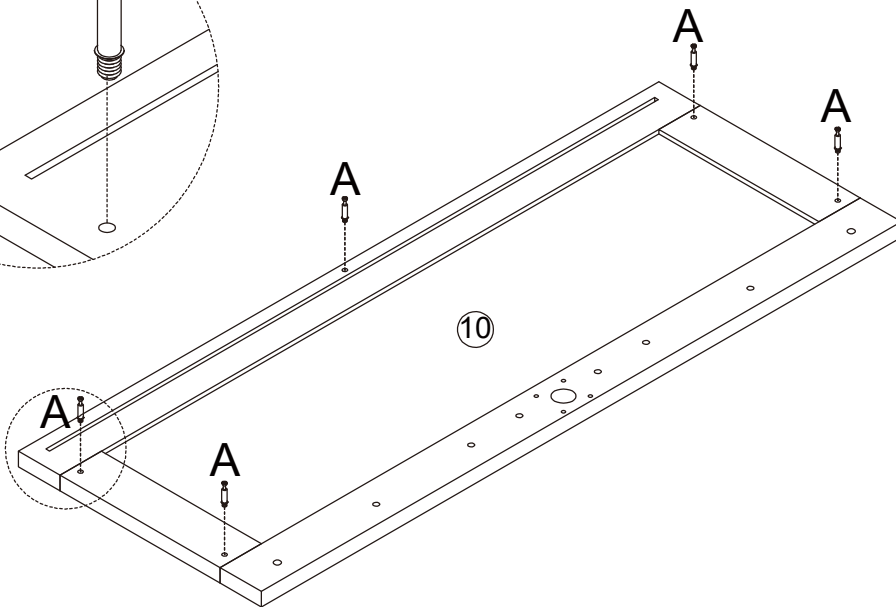
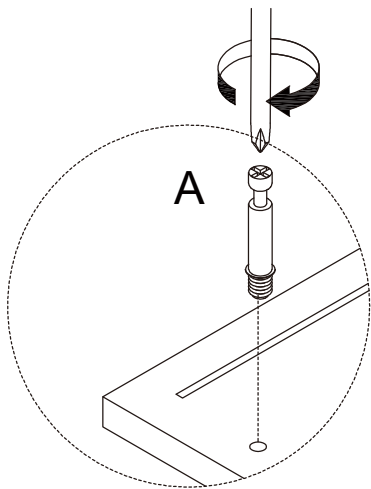
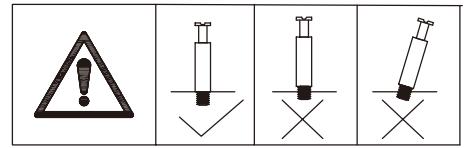

**X2**

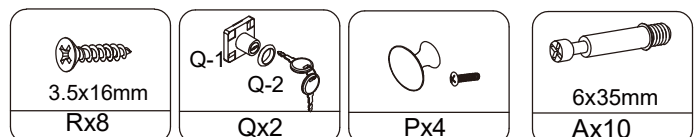

# ASSEMBLY STEPS

**STEP 14** Connect the Drawer Back Panel #11 to the Drawer Support Panel #15 with Screw (D). Note to distinguish the front and back of the Drawer Support Panel

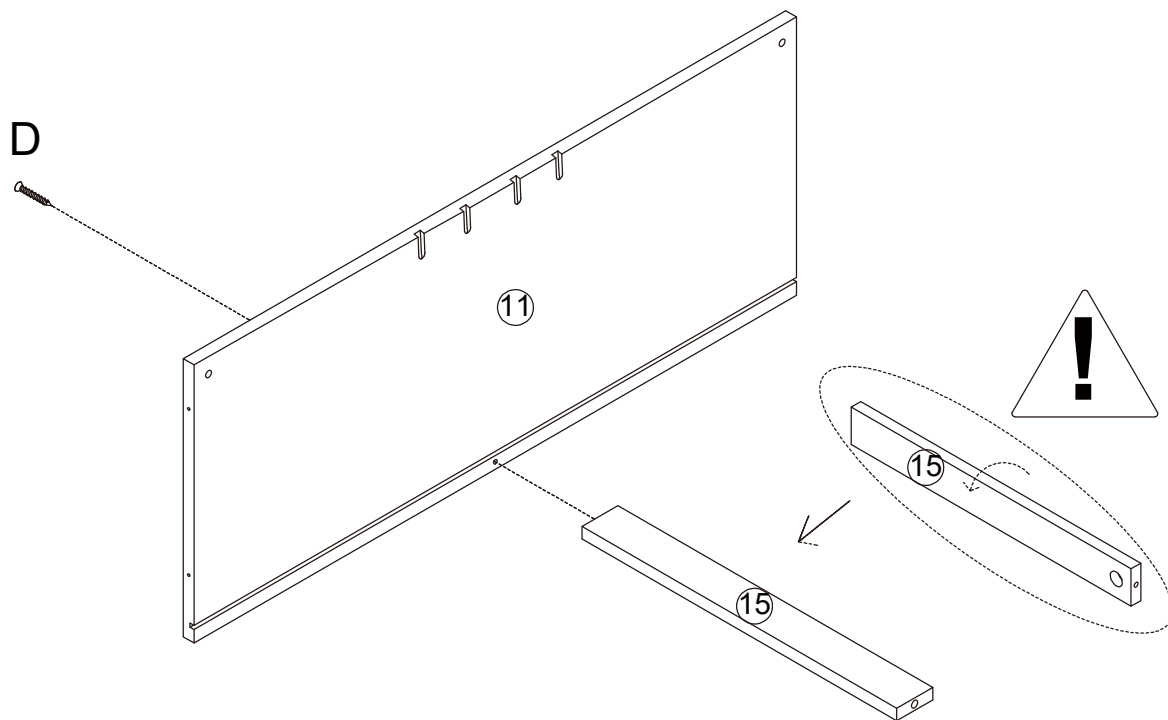

**X2**



# ASSEMBLY STEPS

**STEP 15** Attach the Drawer Slide(J-2) to Panel #13 #14 with Screw(H)

Fix Anti-Tipping Device(S) to Panel #13 with Screw(H)

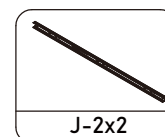
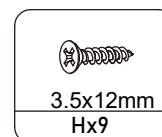
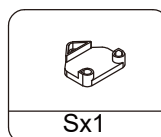
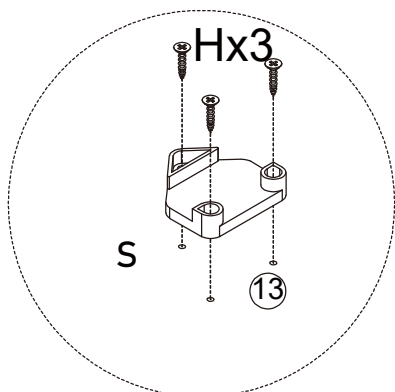
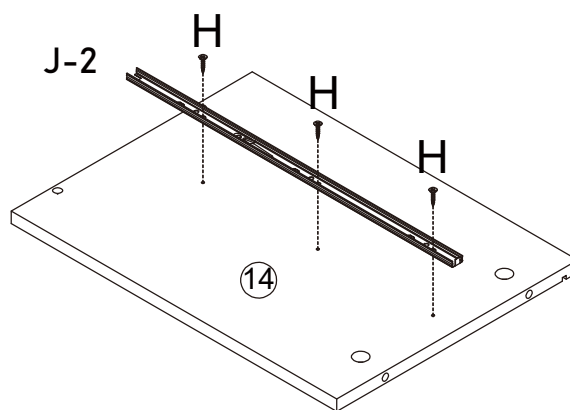
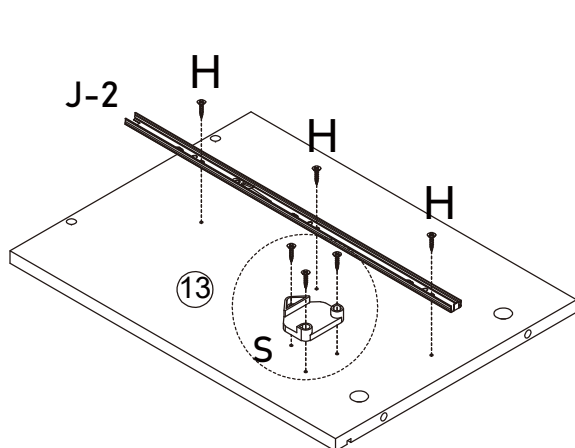
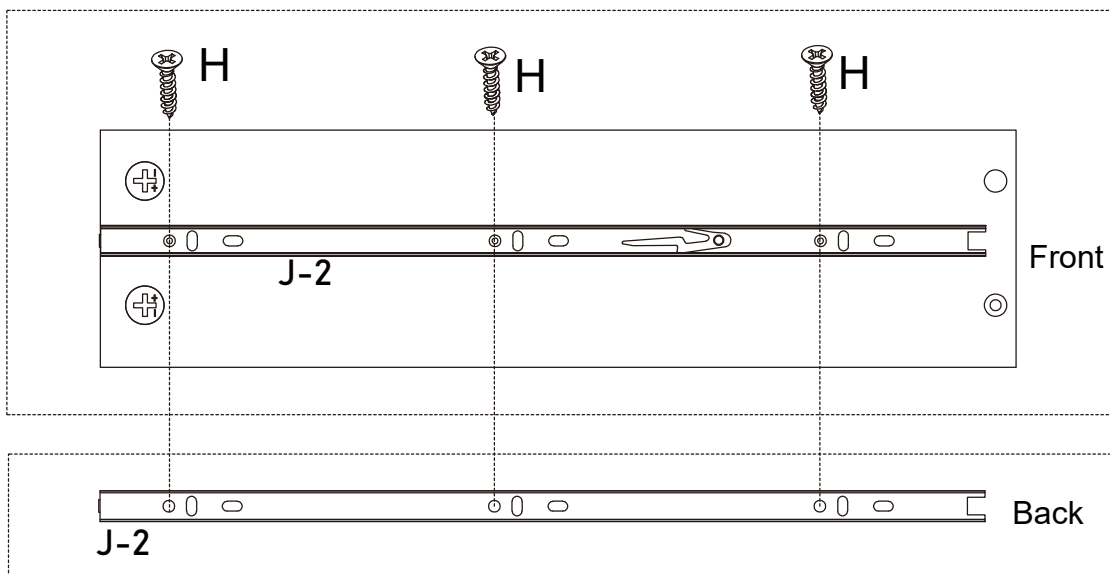



# ASSEMBLY STEPS

**STEP 16** Insert the long rod (U) into the drawer side panel, then screw (D) the drawer side panel # 14 # 16 over the drawer back panel # 11.

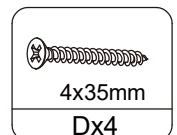
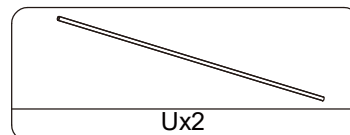
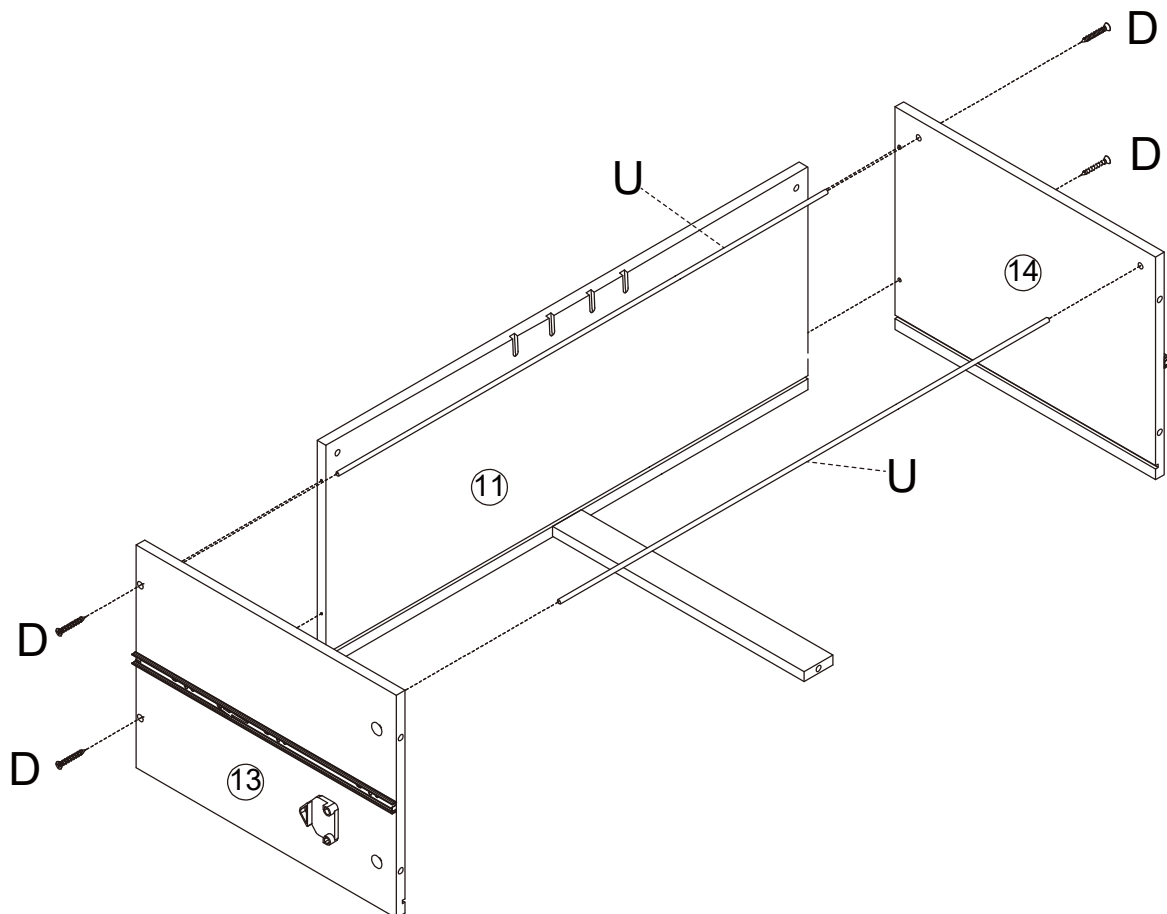

# ASSEMBLY STEPS

- STEP 17** Insert Panel #12 along with the groove;  
Insert the Short Hanging Rod(V) into Panel #11 before next step

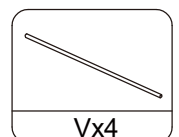
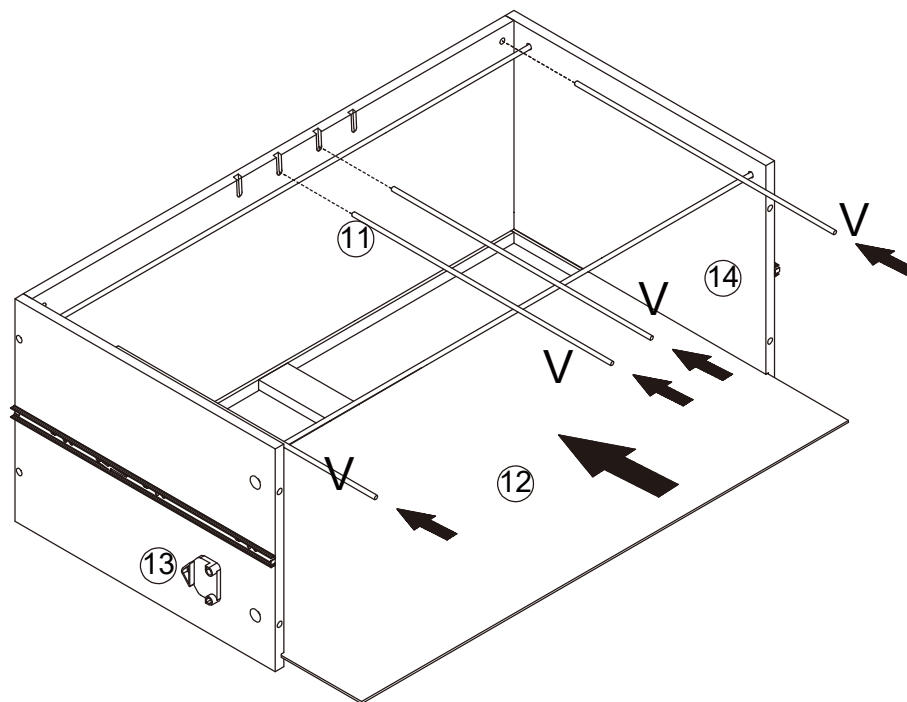

# ASSEMBLY STEPS

**STEP 18** Attach Panel #10 to the drawer body with Cam Lock(B)

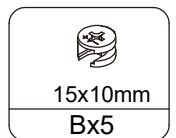
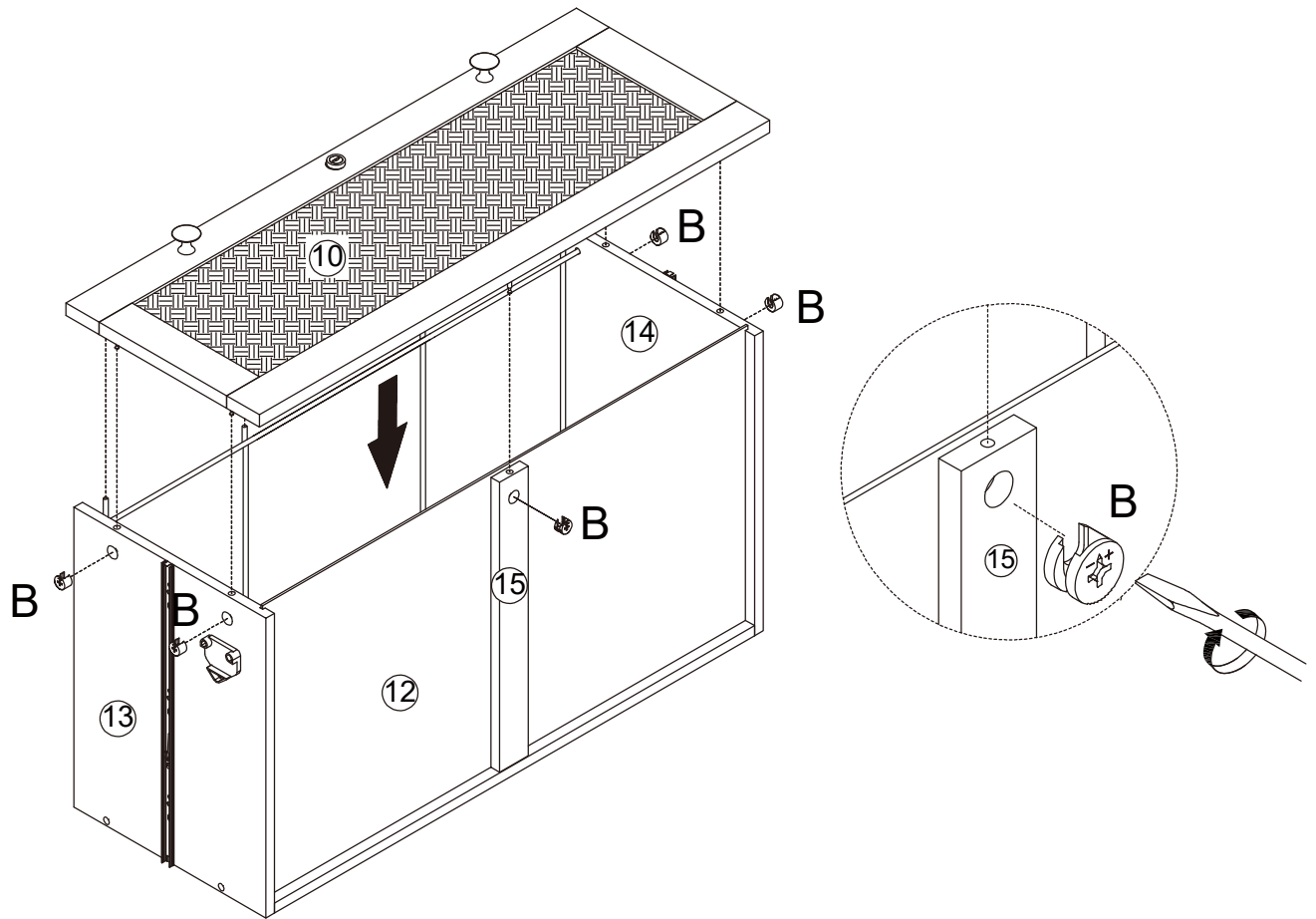

# ASSEMBLY STEPS

**STEP 19** Attach the Drawer Slide(J-2) to Panel #16 #14 with Screw(H)

Fix Anti-Tipping Device(S) to Panel #16 with Screw(H)

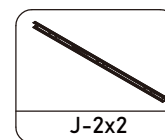
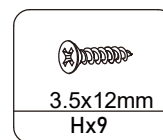
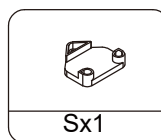
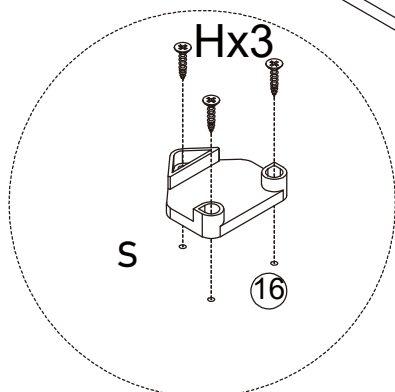
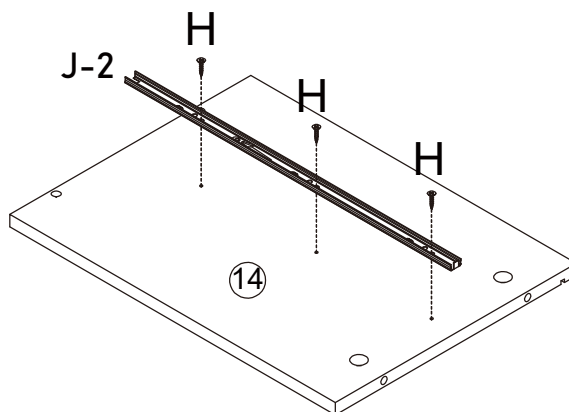
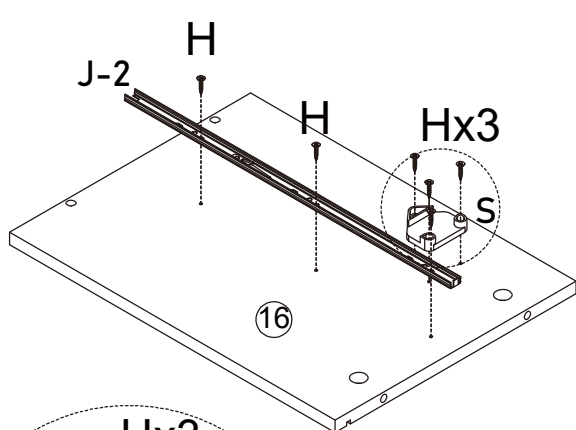
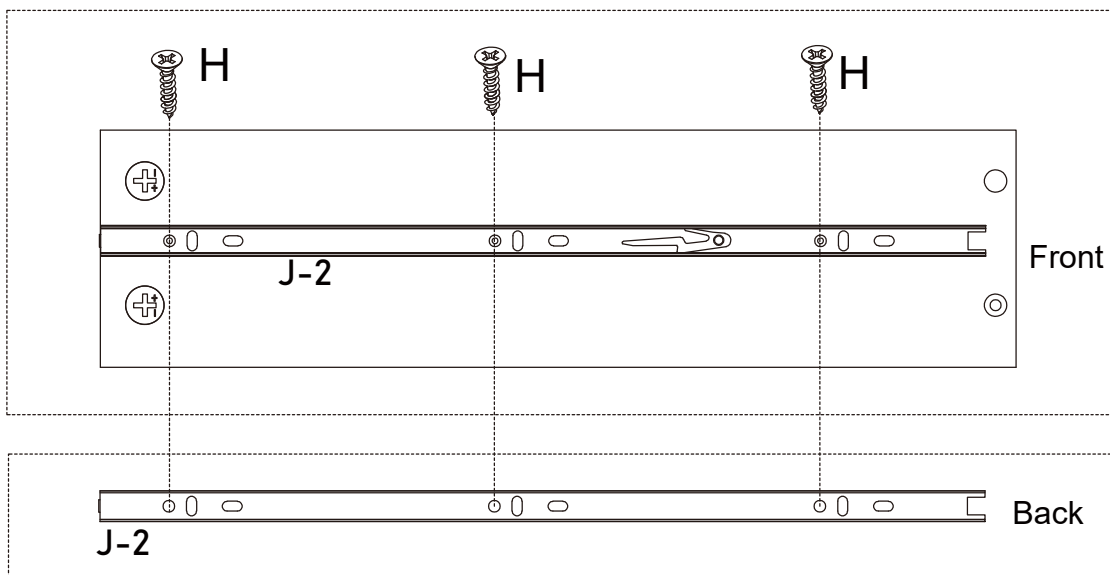

# ASSEMBLY STEPS

## STEP 20

Insert the long rod (U) into the drawer side panel, then screw (D) the drawer side panel # 14 # 16 over the drawer back panel # 11.

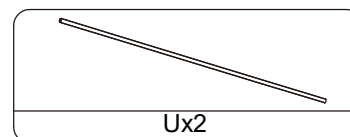
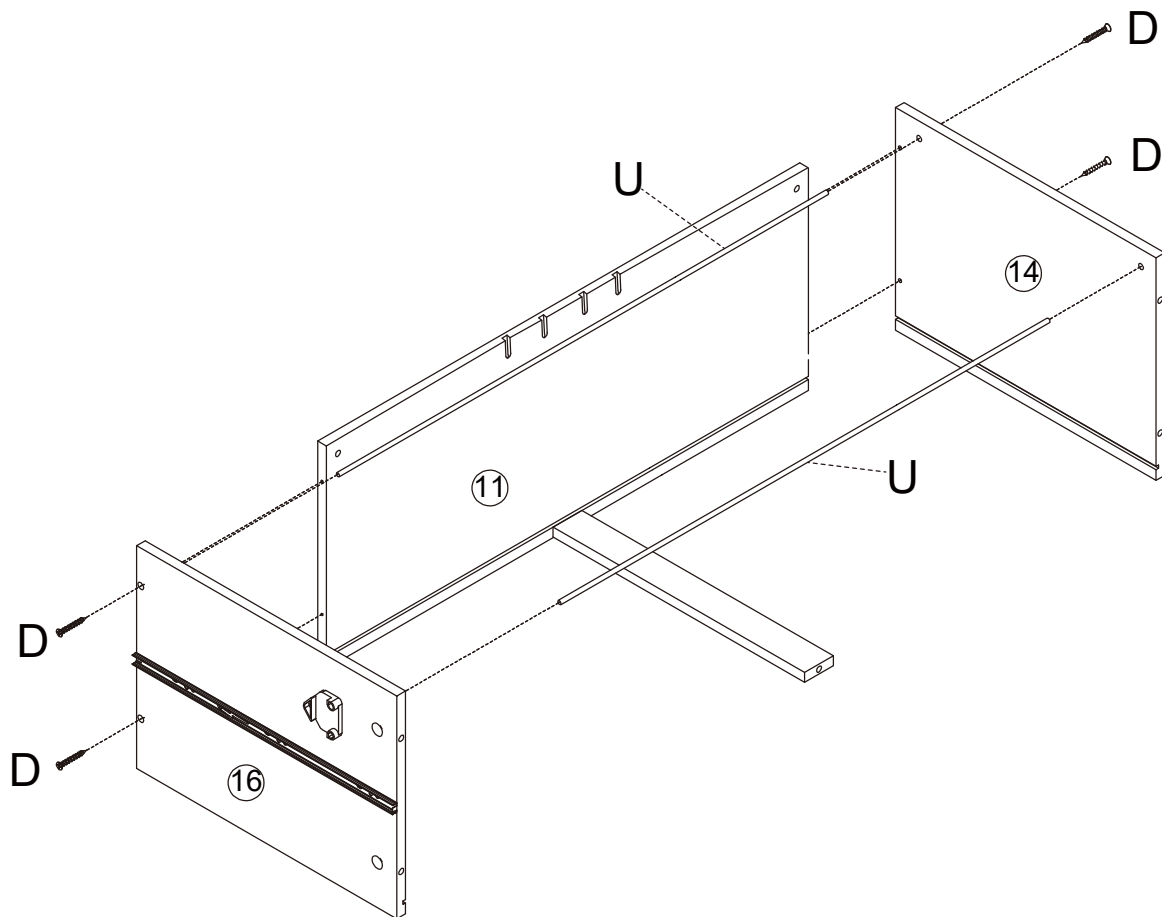

# ASSEMBLY STEPS

**STEP 21** Insert Panel #12 along with the groove;  
Insert the Short Hanging Rod(V) into Panel #11 before next step

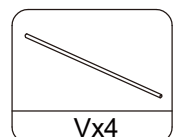
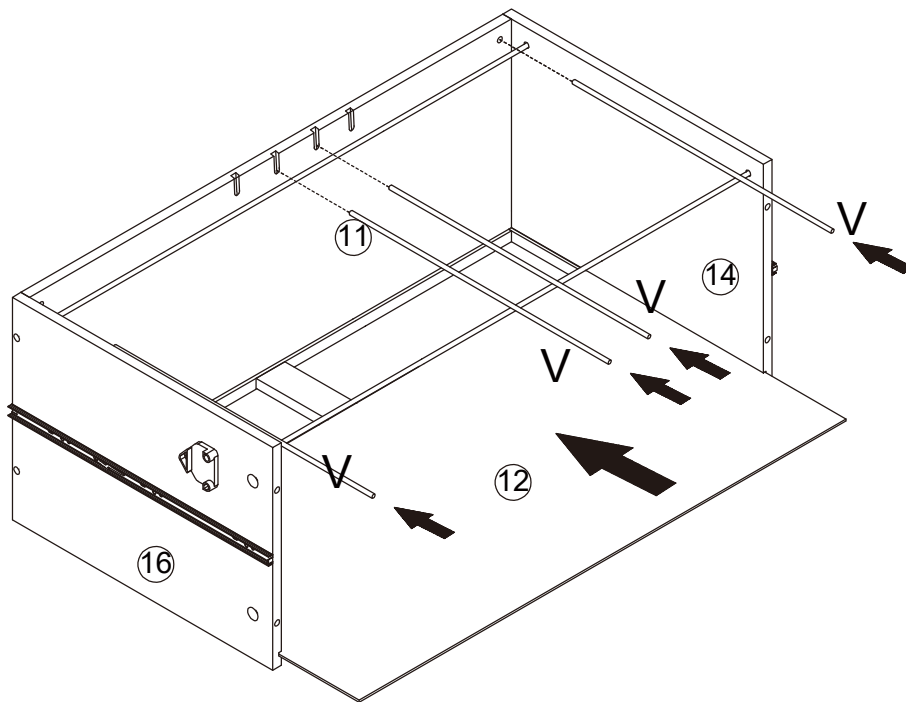

# ASSEMBLY STEPS

**STEP 22** Attach Panel #10 to the drawer body with Cam Lock(B)

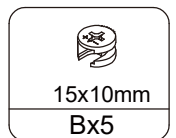
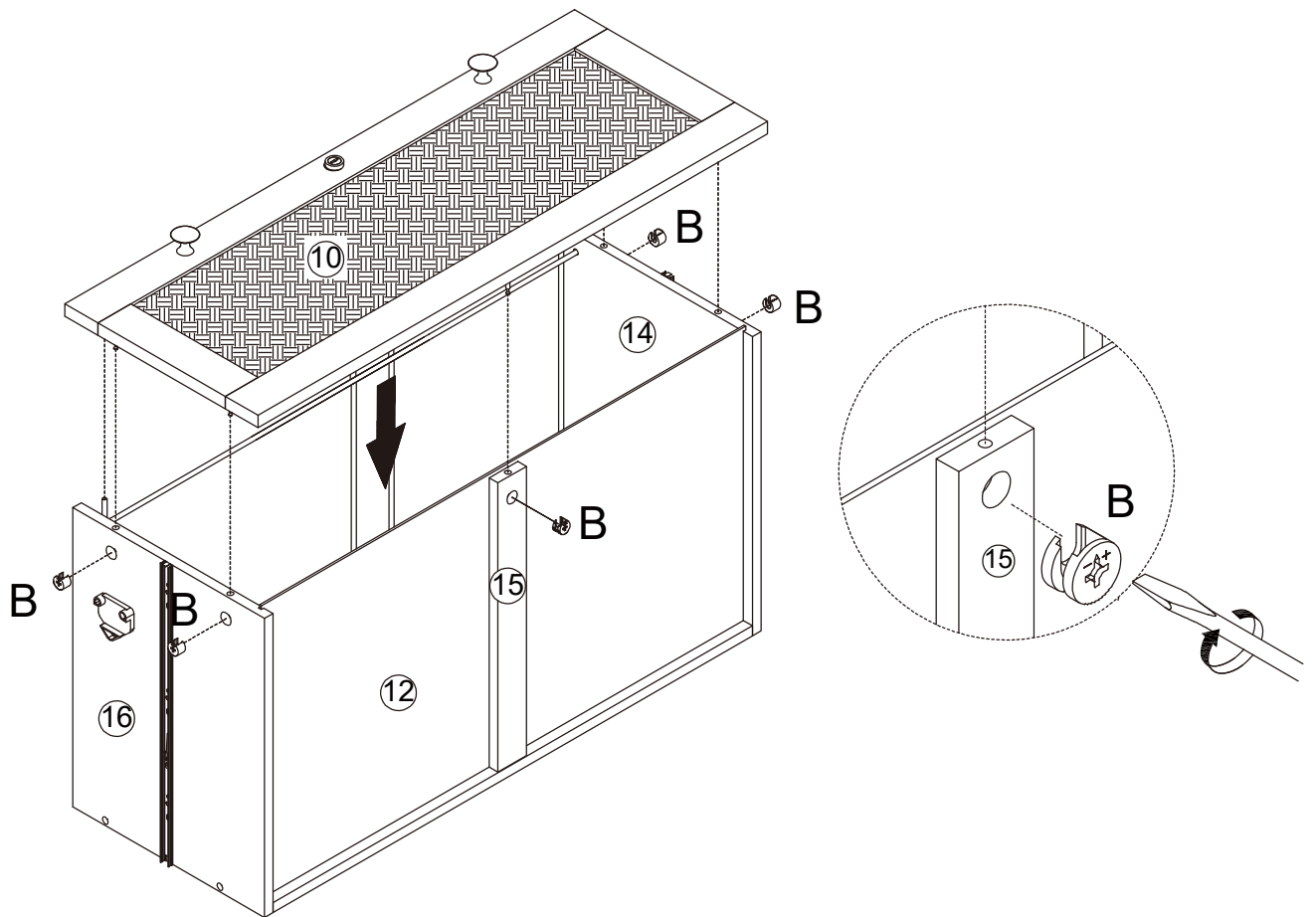

# ASSEMBLY STEPS

**STEP 23** Drill holes in the wall, insert Expansion Screw(W), and fix the item to the wall with Screw(D) for safe use

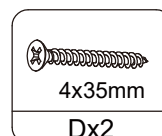
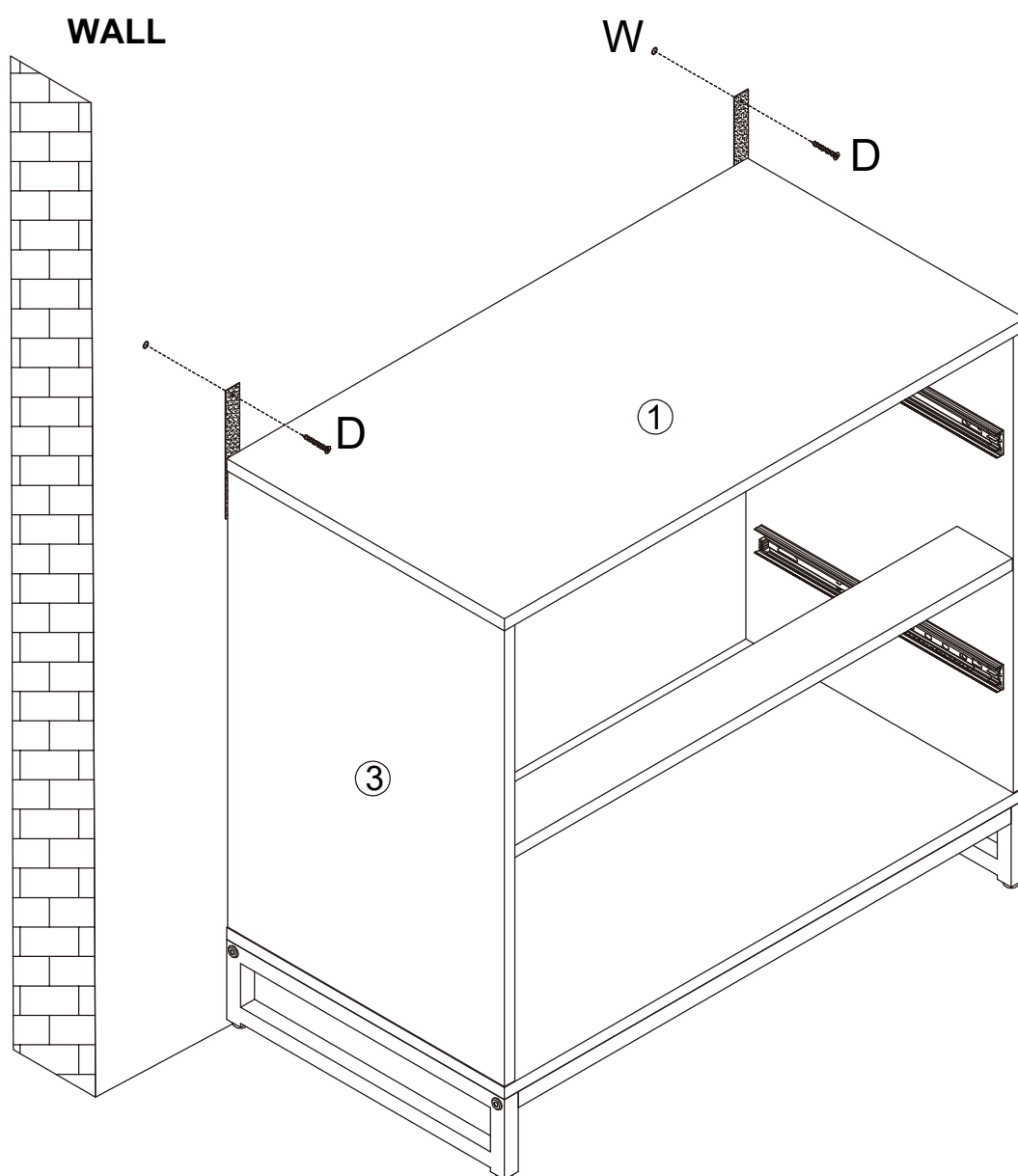
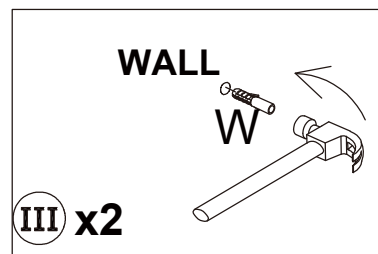
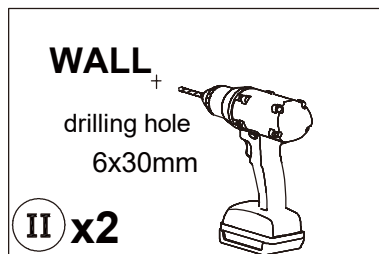
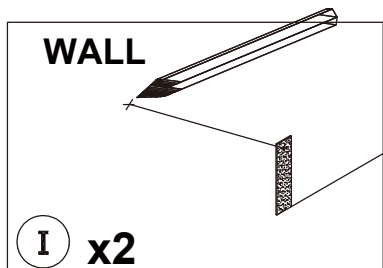



# ASSEMBLY STEPS

**STEP 24** Pull Drawer Slide(J-1) out first, and the ball along with it to the front; Keep the drawer level and insert the drawer with the slides aligned. Note! Failure to level may result in damage to the slides

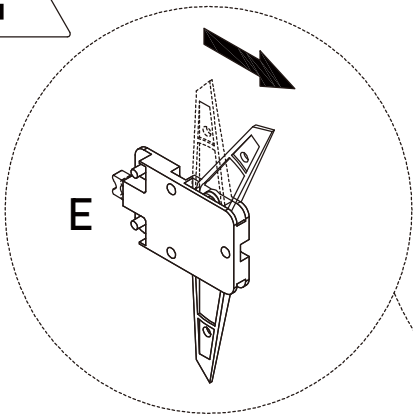

Push the upper snap to the front, and then install the upper drawer

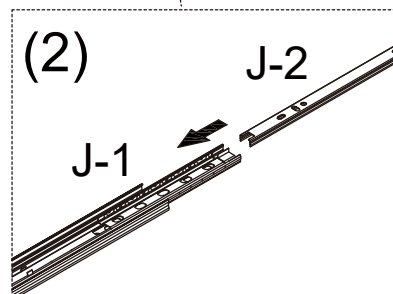
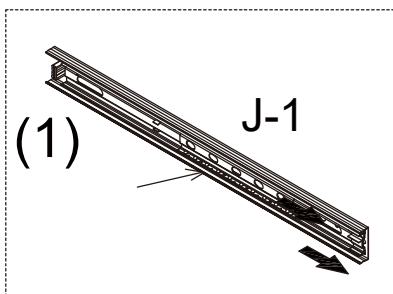
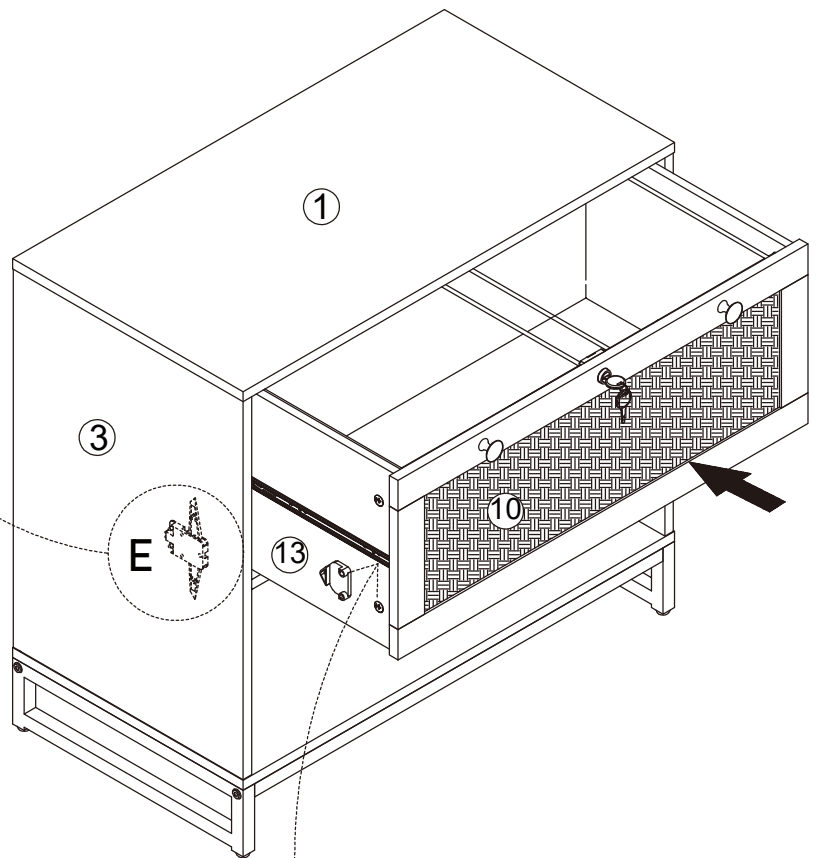

# ASSEMBLY STEPS

**STEP 25** Pull Drawer Slide(J-1) out first, and the ball along with it to the front; Keep the drawer level and insert the drawer with the slides aligned. Note! Failure to level may result in damage to the slides

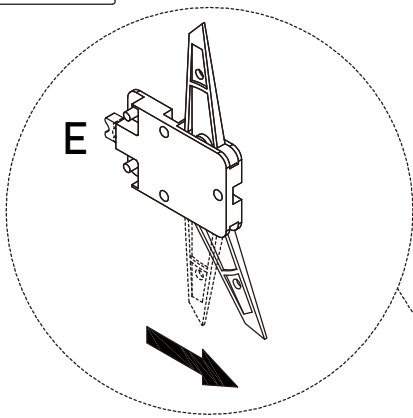

Push the lower snap to the front, and then install the lower drawer

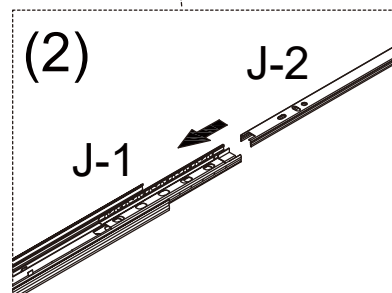
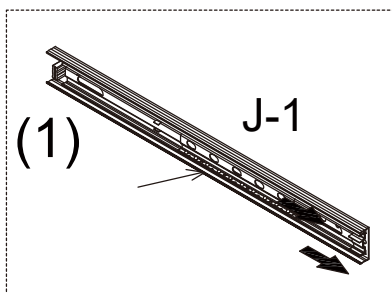
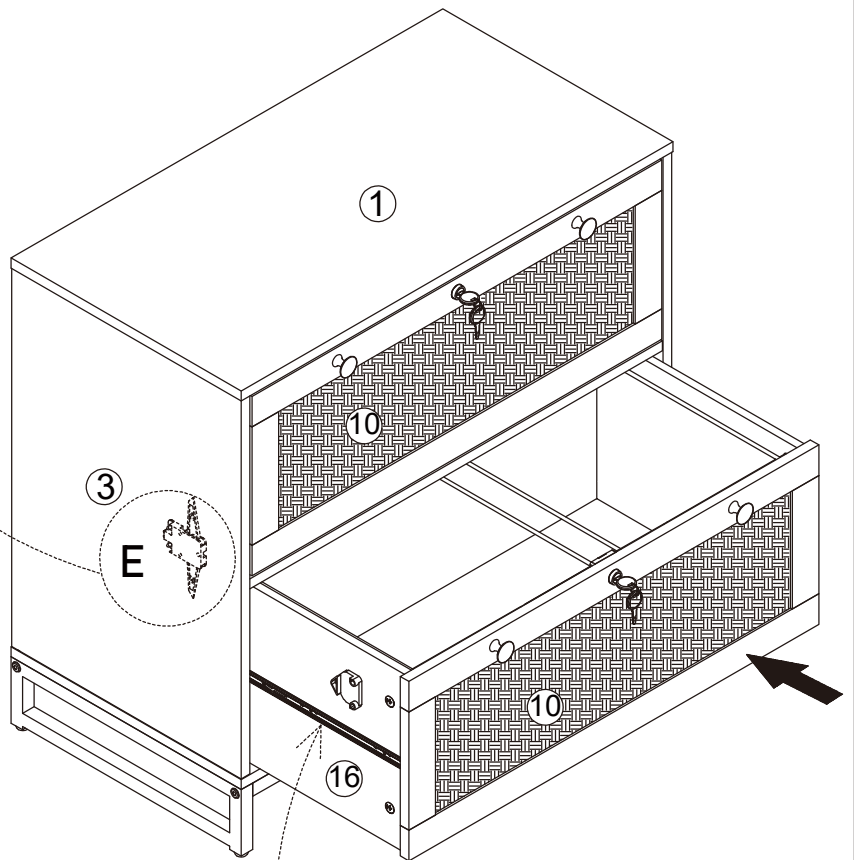

# ASSEMBLY STEPS

## STEP 26



The upper and lower drawers cannot be opened at the same time, one drawer must be closed

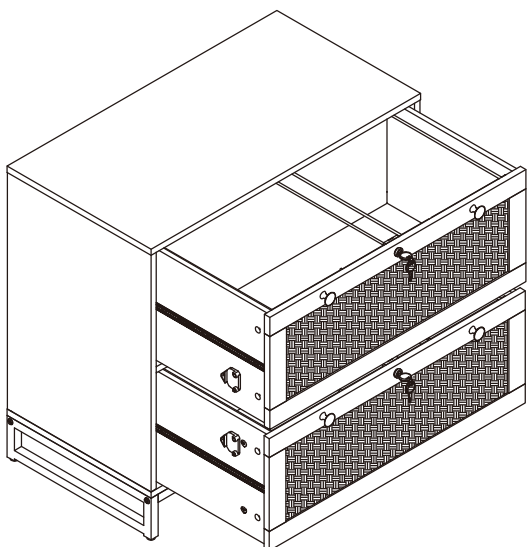
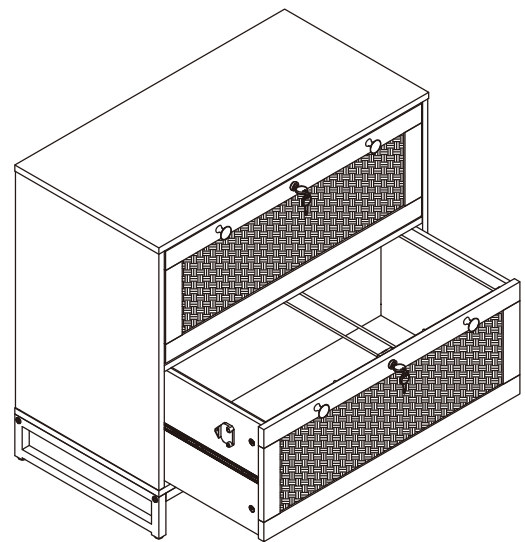
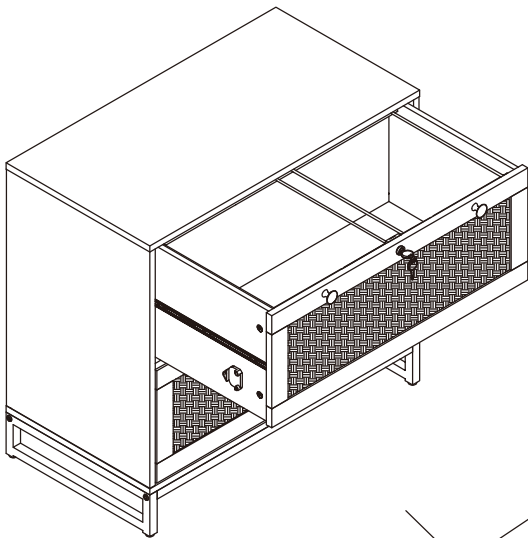

# ASSEMBLY STEPS

**STEP 27** The installation is complete

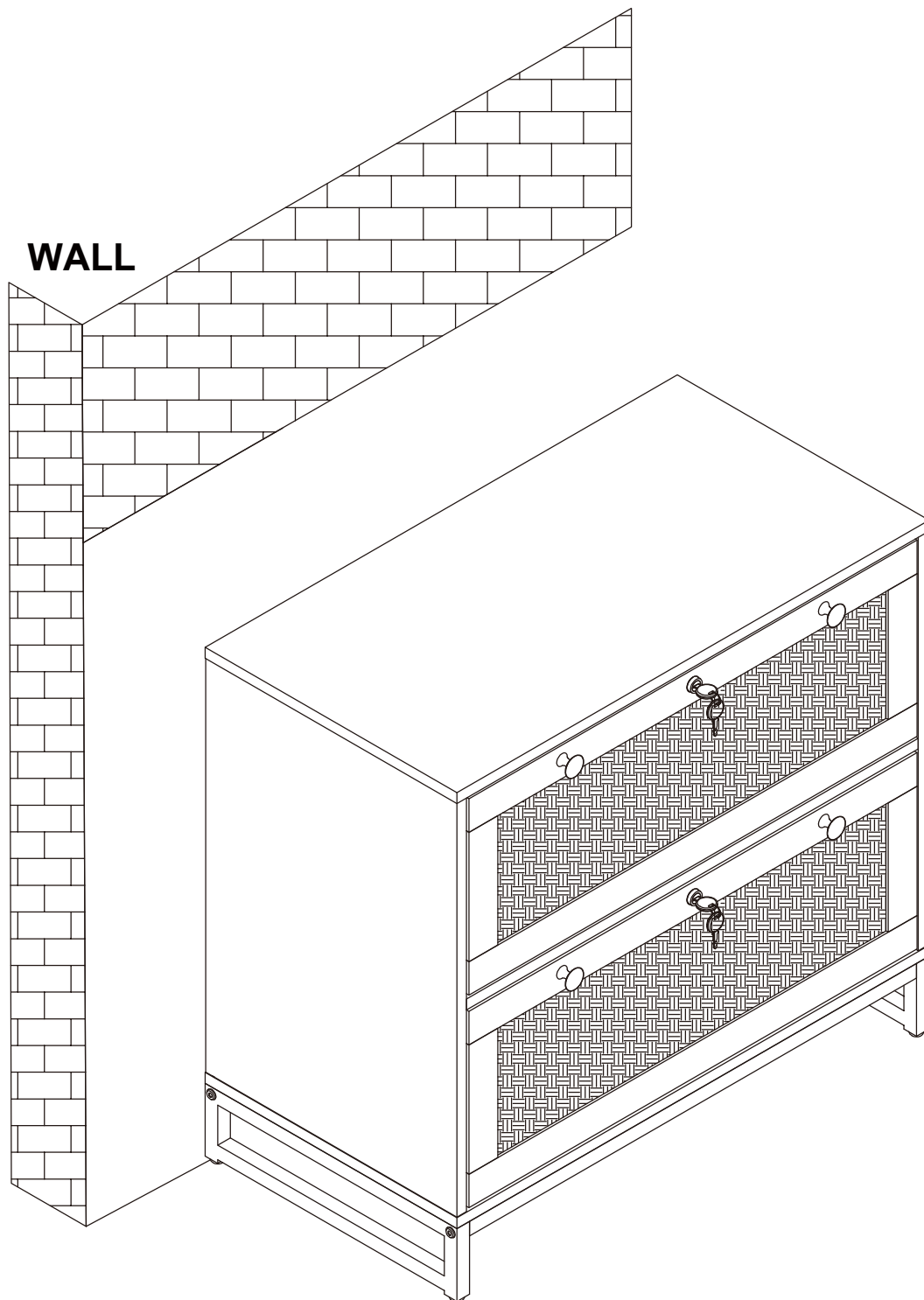

# OPTIONS OF FILE STORAGE

## Option 1

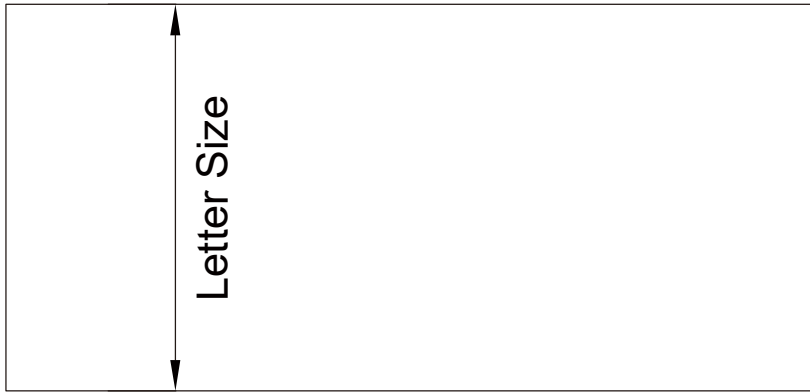

## Option 2

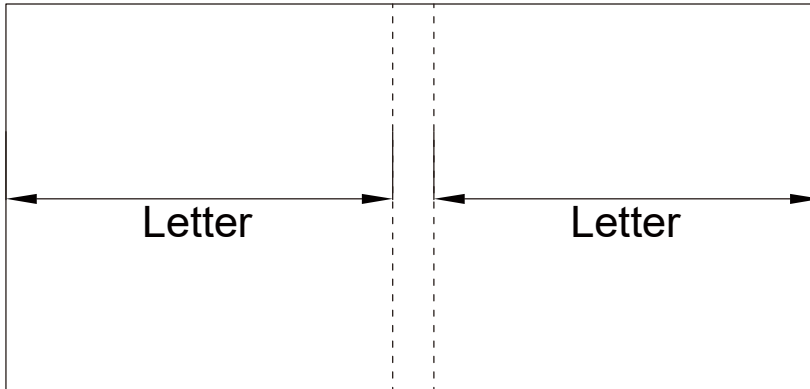

## Option 3

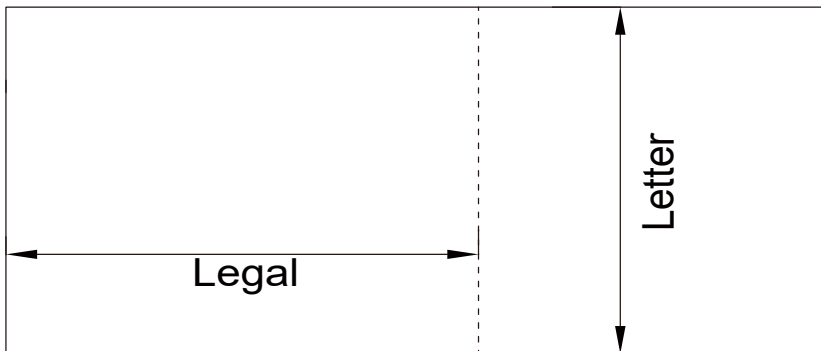

## Option 4

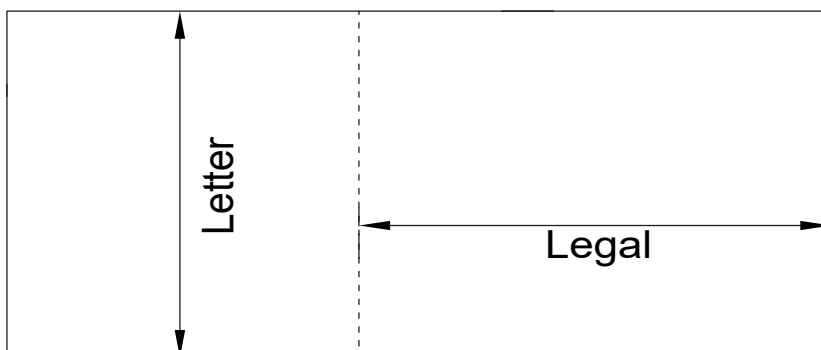

Place the Movable Hanging Rods as needed

# FAQS

## 1. What should I do when I received a defected item or missing parts?

Please feel free to contact VINGLI customer service via the link where you purchased this item with your order ID, pictures & sticker number of the defective/missing parts to us. We are eager to help you to make it right.

---

## 2. Is it easy to put the screws to the Panels?

Yes. As long as you follow the instruction and use the correct screws and put it in correct holes, it is easy to screw it into pre-drilled holes.

---

## 3. What should I do if I have a problem with the drawer not closing flush?

It is usually caused by the assembly of the drawer slides. Here are the solutions as below:

1) Please check whether the slide rail is damaged, for example, the ball of the slide rail has fallen out. If so, please ask us for replacements of the drawer slides;

2) Refer to the assembly manual to check if the holes for the drawer slides are assembled correctly. If there is no problem with the assembly, but the drawer slides are stuck in the process of pushing in, please take out the entire drawer through the release button on the slides (Left Side Up and Right Side Down), and then push it back in again.

---

## 4. Why can both of my drawers open at the same time?

The problem lies in the assembly of the anti-tipping device(E S), please take out both drawers, and check whether the clips of the anti-tipping device(E S) are intact. If they are damaged, please contact us for replacements. Then follow Step 24 and 25 to reassemble the drawers into the cabinet in order.

Any query, please contact us directly.

# Supplementary Instructions for Safe Use

## English

### **WARNING**



Children have died from furniture tipover. To reduce the risk of furniture tipover:

- ALWAYS install tipover restraint provided.
- NEVER put a TV on this product.
- NEVER allow children to stand, climb or hang on drawers, doors, or shelves.
- NEVER open more than one drawer at a time.
- Place heaviest items in the lowest drawers.
- Do not defeat or remove the drawer interlock system.

This is a permanent label.  
Do not remove!

## French

### **ATTENTION**



Des enfants sont morts du basculement des meubles. Pour réduire le risque de basculement des meubles:

- TOUJOURS installer la retenue de basculement fournie.
- NE JAMAIS mettre de téléviseur sur ce produit.
- NE JAMAIS permettre aux enfants de se tenir debout, de grimper, ou de s'accrocher à des tiroirs, des portes ou des étagères.
- N'ouvrez JAMAIS plus d'un tiroir à la fois.
- Placez les objets les plus lourds dans les tiroirs les plus bas.
- Ne désactivez pas et ne retirez pas le système de verrouillage du tiroir.

Ceci est une étiquette permanente.  
Ne pas enlever!

## German

### **WARNUNG**



Kinder sind an einem Möbelkipp gestorben. So verringern Sie das Risiko eines Umkippens von Möbeln:

- Installieren Sie **IMMER** die mitgelieferte Kipprückhaltevorrichtung.
- Stellen Sie **NIEMALS** einen Fernseher an dieses Produkt.
- Lassen Sie Kinder **NIEMALS** an Schubladen, Türen oder Regalen stehen klettern oder hängen.
- Öffnen Sie **NIEMALS** mehr als eine Schublade gleichzeitig.
- Legen Sie schwerste Gegenstände in die untersten Schubladen.
- Besiegen oder entfernen Sie das Schubladenverriegelungssystem nicht.

Dies ist ein dauerhaftes Etikett.  
Nicht entfernen!