

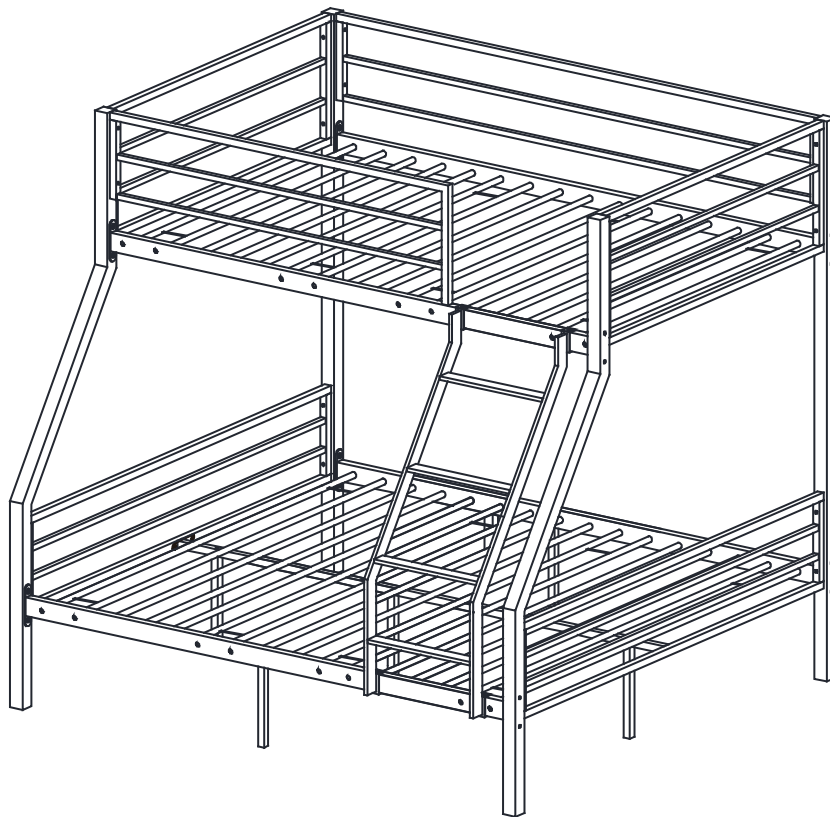

## BUNK BED



Note: This bed frame comes in two boxes.

Thank you for your purchase.

If you have difficulty with assembly or find a part is missing or damaged, please don't hesitate to contact us for solution. Here is how we can connect:

Email: [Support@bonnlo.com](mailto:Support@bonnlo.com)

Facebook: <https://www.facebook.com/BonnloDirect/>

Please attach your Order ID so we can assist you better.

# Introduction

## ● Guide of Manual

Please read the following instruction carefully and use the product properly.

Please keep this manual and hand it over when you transfer the product.

This summary may not include every detailed information of all variations and considered steps. Please contact us when further information and help needed.

## ● Before Starting

Recommend no. of people needed for assembly: 4-5

Read each section carefully before starting. It is very important that each step is performed in the correct order. If these steps are not followed in sequence, assembly difficulties will occur.

Make sure all parts are included. Most board parts are labeled or stamped on the raw edge.

Please assemble the product according to the steps on the diagram strictly. Do not fully tighten the screws until all pieces are situated in place.

For continued use, it's suggested you regularly check the tightness of bolts and connections to ensure safety.

Work in spacious area, preferably on a carpet, near the place the unit will be

## ● Warning

Keep all accessories and packaging of this product away from babies, children and pets as they potentially

The units contains small parts which could be a choking hazard for small children. Children should be under adult supervision at all times or serious injury could occur.







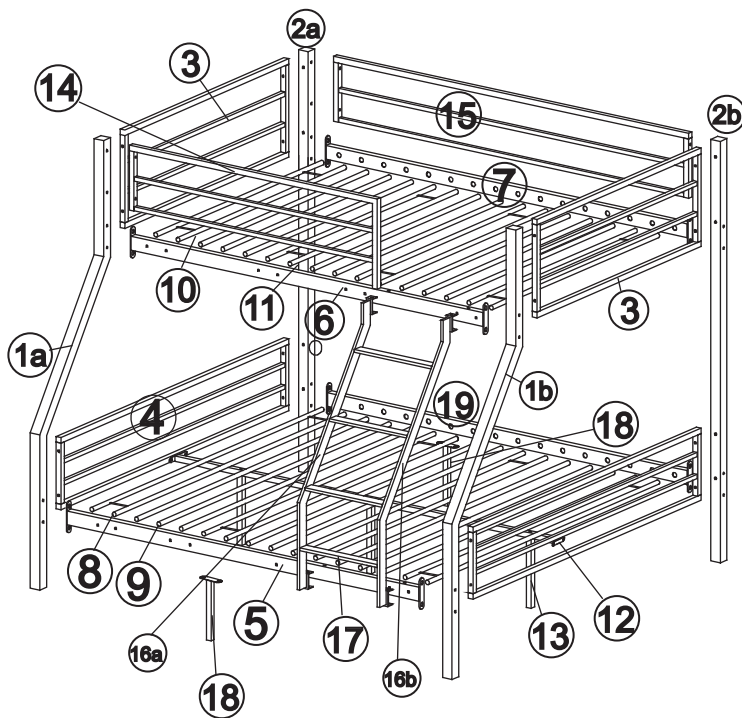











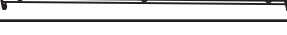

Do not put the product in a humid environment for a long time to prevent mildew.

Keep the product away from sharp objects and corrosive chemicals to avoid damage.

# Part List 1



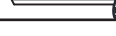



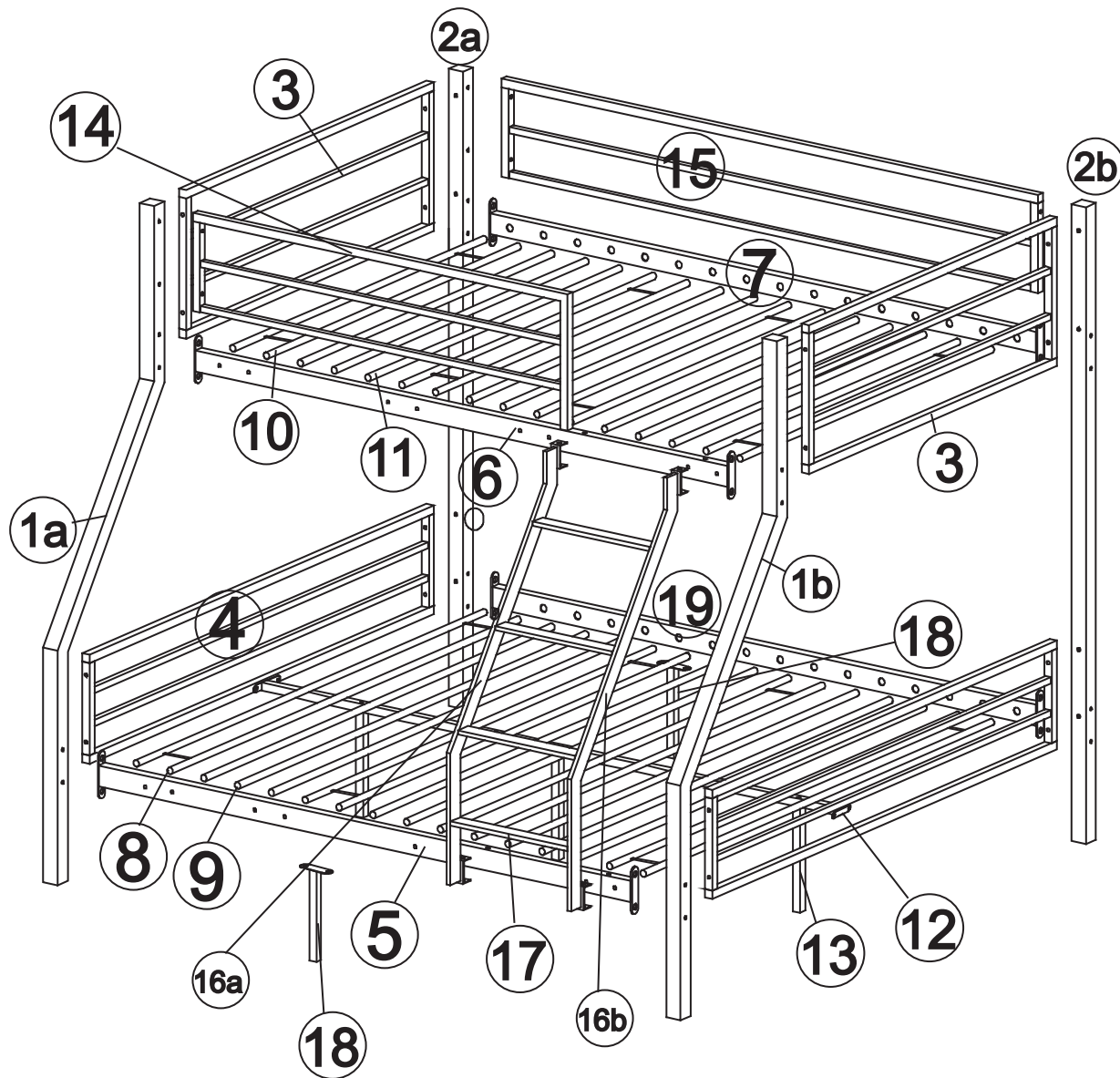

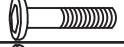

## COMPONENTS

NO.	DESCRIPTION		DIMENSION	QTY
1a	Front left column		40x420x1520mm	1pc
1b	Front right column		40x420x1520mm	1pc
2a	Rear left column		40x40x1520mm	1pc
2b	Rear right column		40x40x1520mm	1pc
3	Upper bed side fence		20x355x975mm	2pcs
4	Lower bed side fence		20x260x1355mm	2pcs
5	Lower bed front bar		25x110x1900mm	1pc
6	Upper bed front bar		25x110x1900mm	1pc
7	Upper bed rear bar		25x110x1900mm	1pc
8	Lower bed round tube		Φ16x1416	4pcs
9	Lower bed round tube with built-in nut		Φ16x1413	8pcs
10	Upper bed round tube		Φ16x1036	4pcs
11	Upper bed round tube with built-in nut		Φ16x1033	8pcs
12	Middle bar		20x20x1920mm	1pc
13	Supporting legs		20x20x260mm	3pcs
14	Upper bed front fence		20x325x1451mm	1pc
15	Upper bed rear fence		20x234x1900mm	1pc
16a	Ladder left bracket		20x920x438mm	1pc
16b	Ladder right bracket		20x920x438mm	1pc
17	Pedal		10x40x323mm	4pcs
18	Middle support leg		25x25x260mm	2pcs
19	Lower bed rear bar		25x110x1900mm	1pc



COMPONENTS

NO.	DESCRIPTION	DIMENSION	QTY
A	Screws	 M6x10	8pcs
B	Screws	 M6x20	40pcs
C	Screws	 M6X35	41pcs
D	Screws	 M6X45	4pcs
E	Screws	 M6X65	1pc
F	Nuts	 M6X18	20pcs
G	Flat Washer		42pcs
H	Rubber Mat		4pcs
I	Spanner	 M6	2pcs



# Assembly Steps

## STEP 1

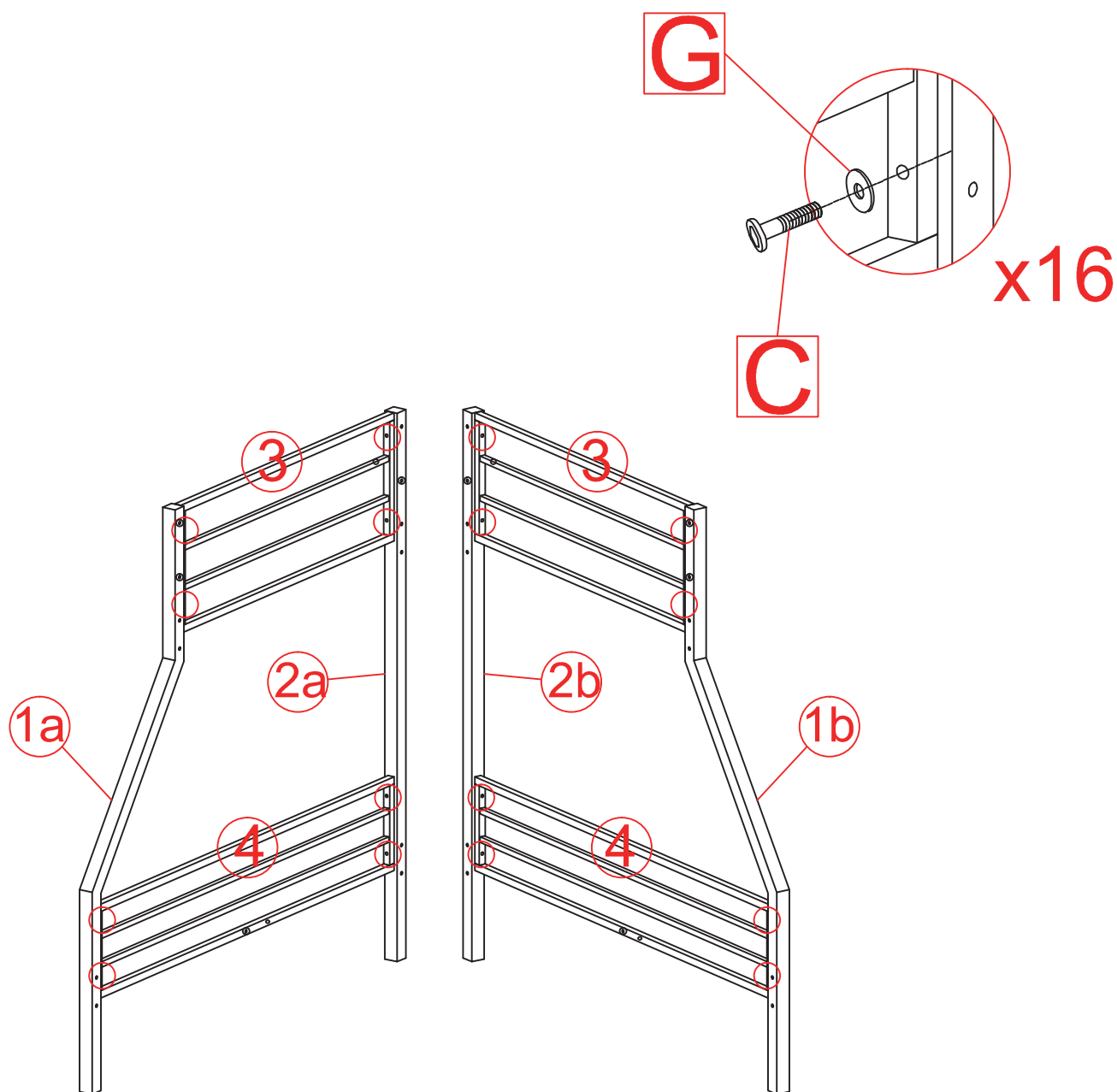
Assemble column and side fence



Assembly method: M6x35 screw (C) is screwed from the screw hole on fence inside. Connect fence (3 & 4) to column (1a & 1b & 2a & 2b). And pad flat washer (G) between screw and fence.

CODE	HARDWARE	QTY
C	 M6X35	16
G		16

## STEP 2

Assemble lower bed plat

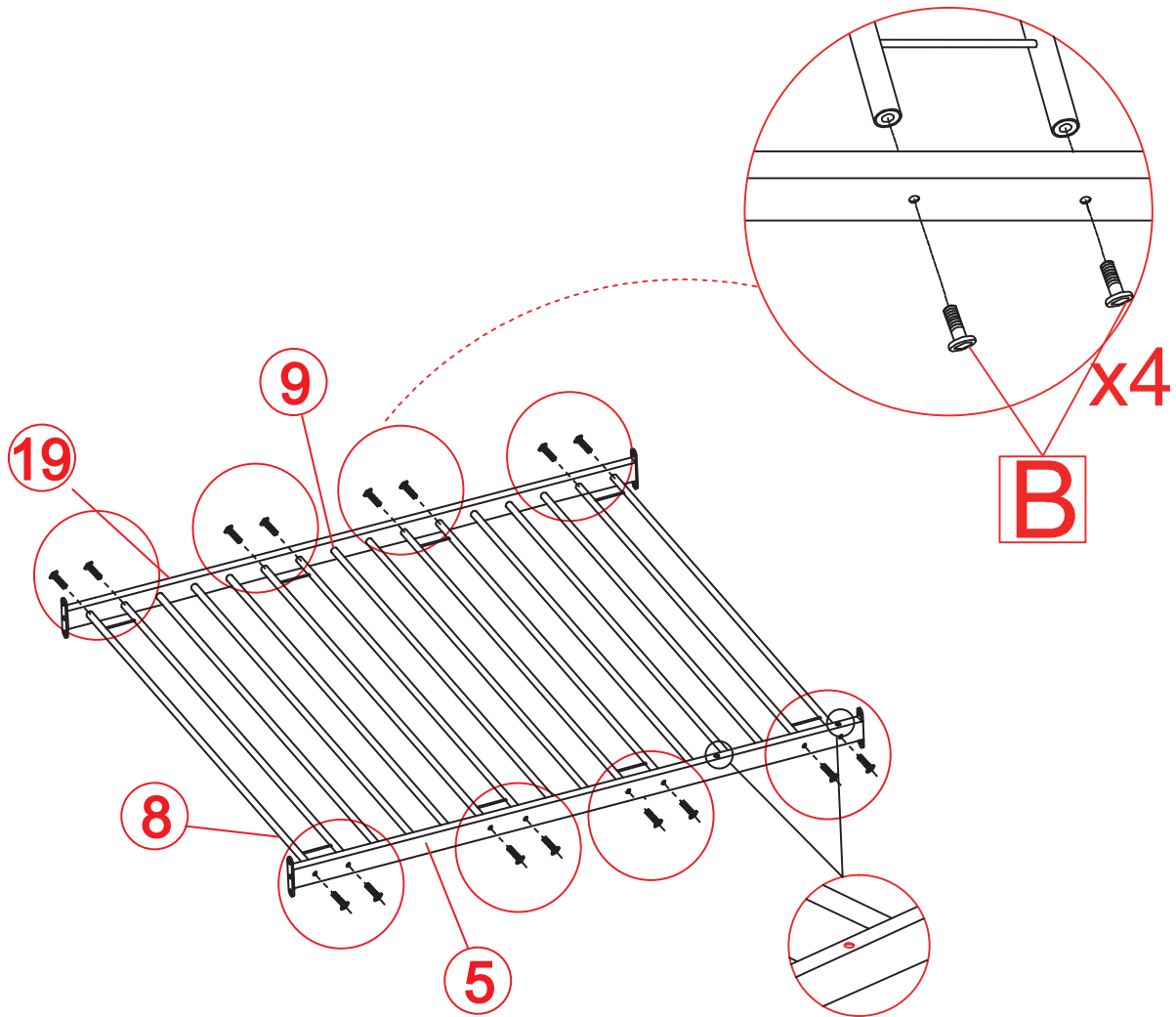

Assembly method:

This step requires at least 4 people to assemble, please install the slat from one end to the other. Put Round Tube with built-in nut (8) and the Round Tube (9) into the bed bar (5 and 19). Note that the Round Tube with the built-in nut (8) is placed in round holes with screw holes, and the other holes are all covered with Round Tubes (9). Fix Bed Bar (5 and 19) and Round Tubes with built-in nut (8) with Screw (B).

CODE	HARDWARE	QTY
B	 M6X20	16

## STEP 3

Assemble upper bed plates

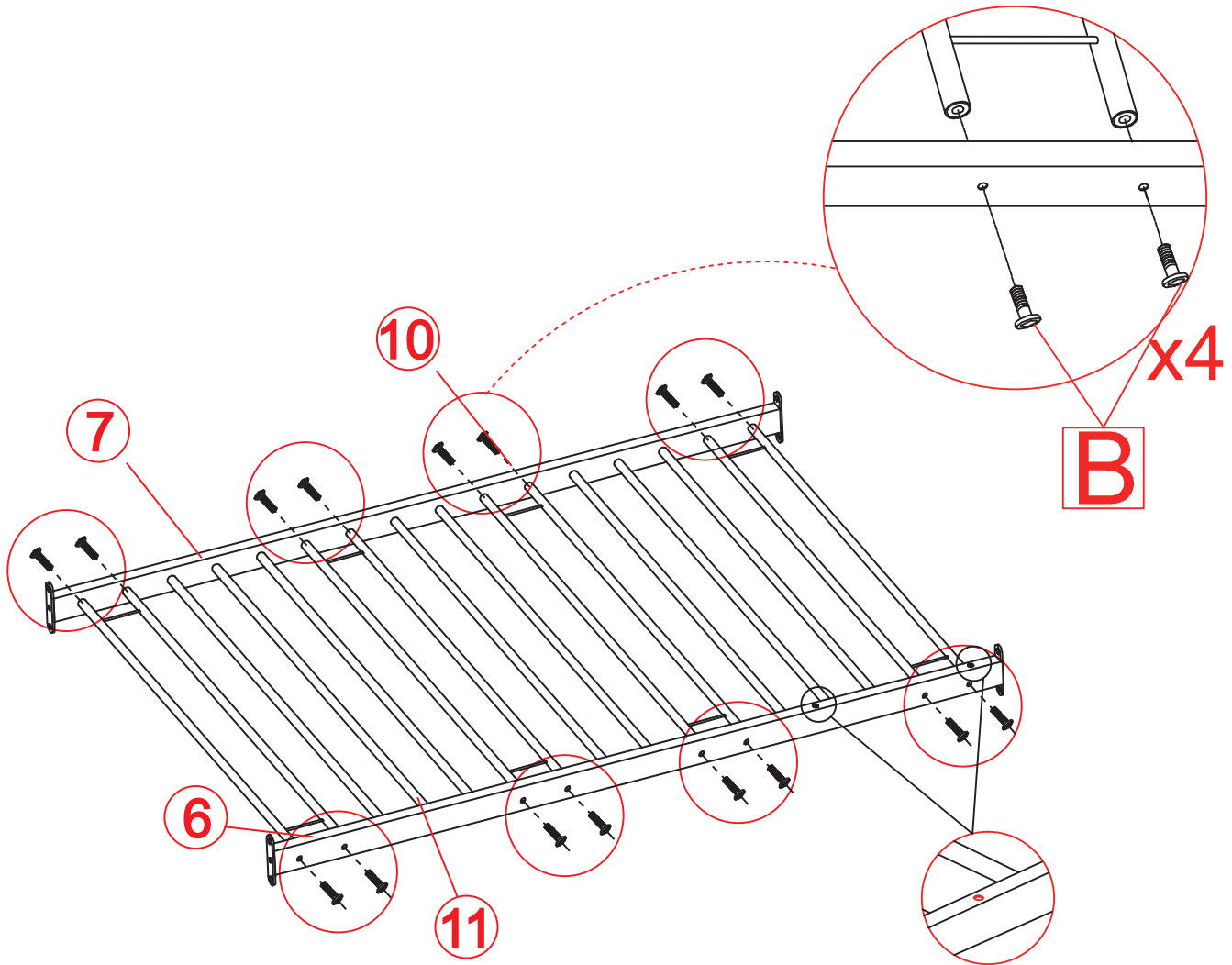

### Assembly method:

This step requires at least 4 people to assemble, please install the slat from one end to the other. Insert round tube (11) and round tube with built-in nut (10) to bed bar (7 & 11). Note that the Round Tube with the built-in nut (10) is placed in round holes with screw holes, and the other holes are all covered with Round Tubes (11). Fix Bed Bar (7 and 11) and Round Tubes with built-in nut (10) with Screw (B).

CODE	HARDWARE	QTY
B	 M6X20	16

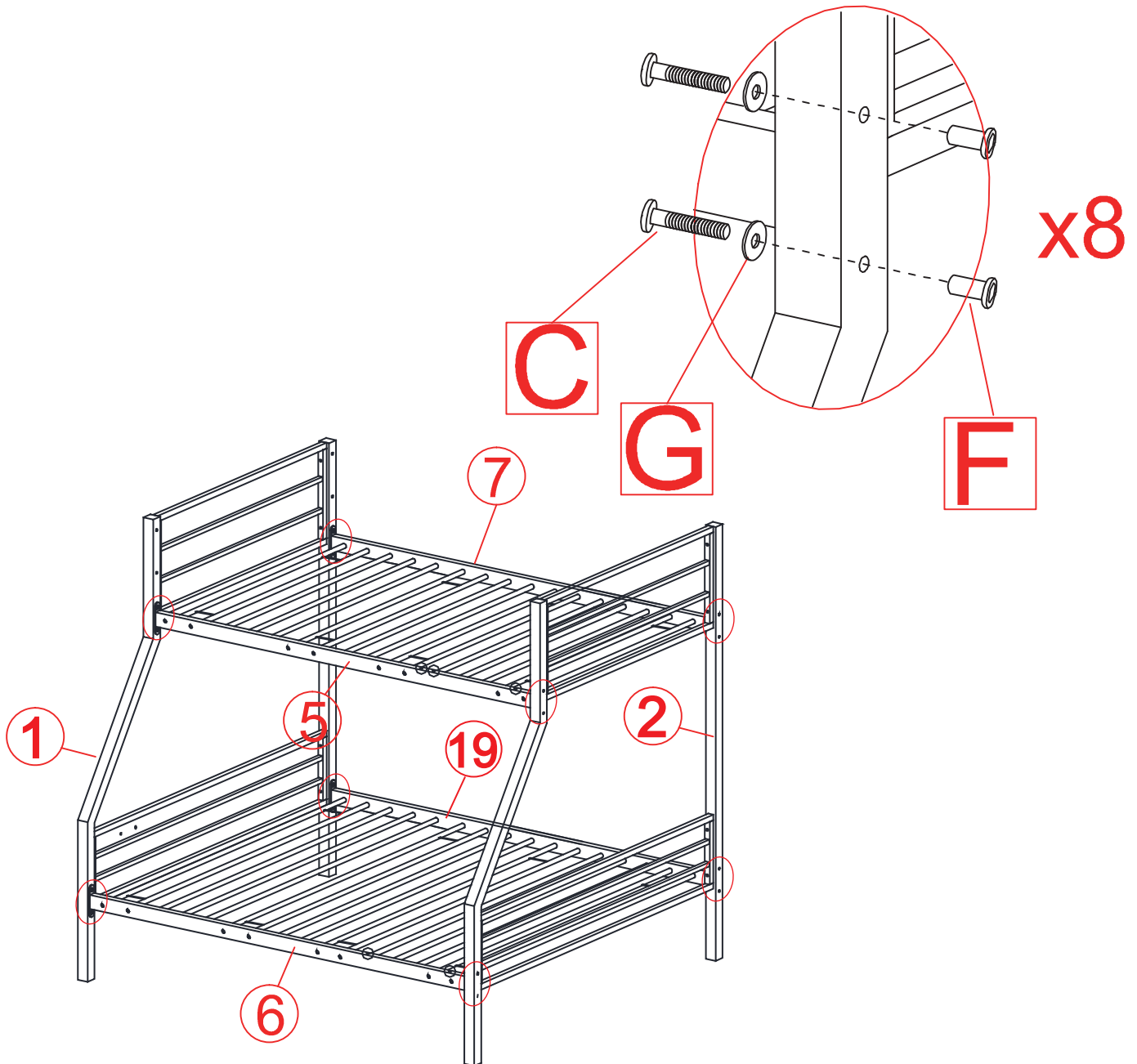

## STEP 4

Assemble the two assembled sides and the bed plate together



Assembly method:

Assemble M6x35 screw (C), M6x18 jcn nut (F) and flat washer (G) as shown. Assemble M6x35 screw (C) on the outside of column. Assemble one side of lower bed plate, the screw is fixed and do not tighten. And then install the other side. After the lower bed is fixed, fix the upper bed, and the assembly method is the same as that of the lower bed.

CODE	HARDWARE	QTY
C	 M6X35	16
F	 M6X18	16
G		16



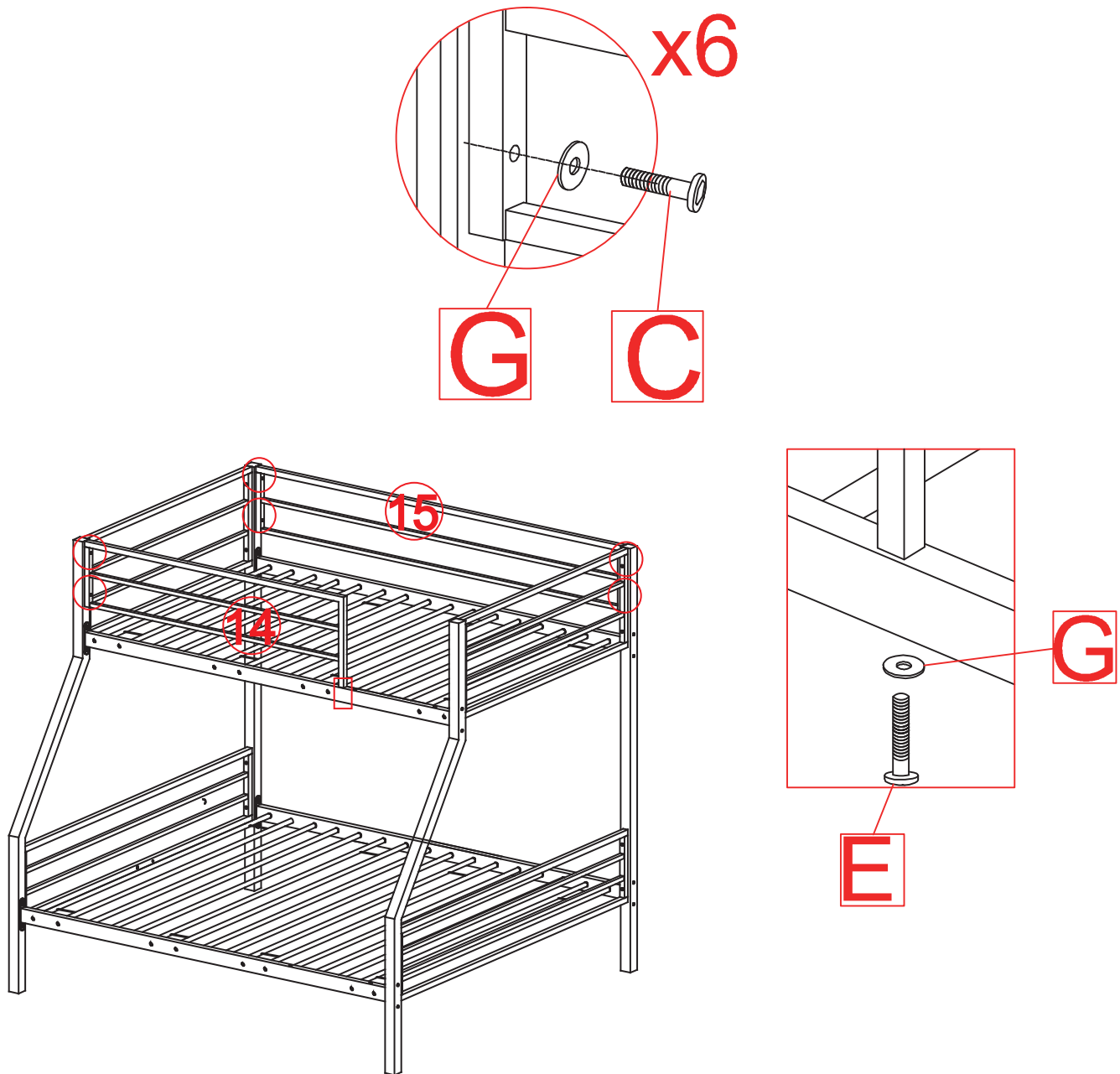

# STEP 5

Assemble upper bed fence



Assembly method:

Firstly, assemble circular marks part on the figure. Fix fence (14 & 15) on the column with M6x35 screw (C) and flat washer (G). Then assemble square marks part on the figure. M6x65 screw (E) and flat washer (G) are screwed upward from screw hole on the bottom of bed bar to fix fence (14).



CODE	HARDWARE	QTY
C	 M6X35	6
E	 M6X65	1
G		7

## STEP 6

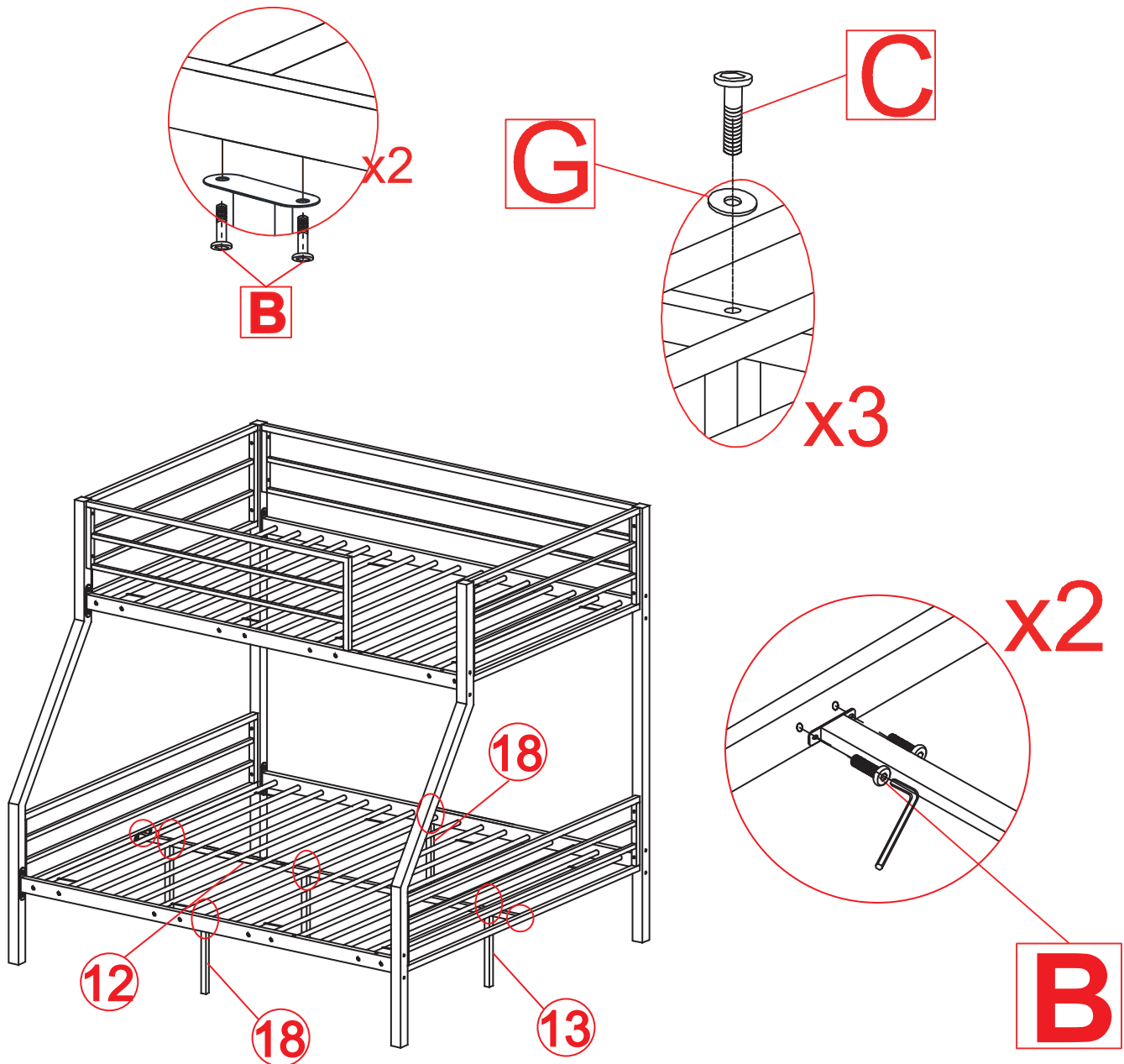
Assemble middle bar and supporting legs of lower bed



- Use Screw (B) to connect Middle Bar (12) to the two sides of the fence.
- Use Screw(C) to connect the Support Leg (13) to the Middle Bar (12) with Washer (G) on the middle.
- Use Screw(B) to connect the middle support leg to the Lower bed Side Rail(5)

CODE	HARDWARE	QTY
C	 M6X35	3
G		3
B	 M6X20	8

## STEP 7

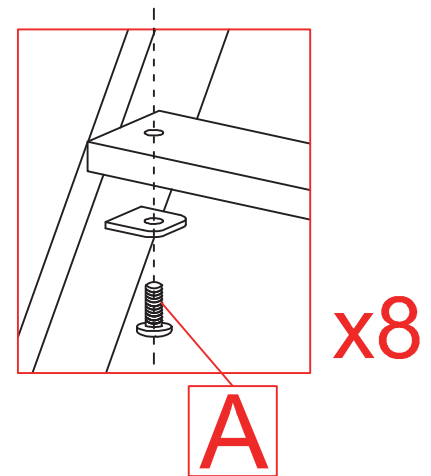
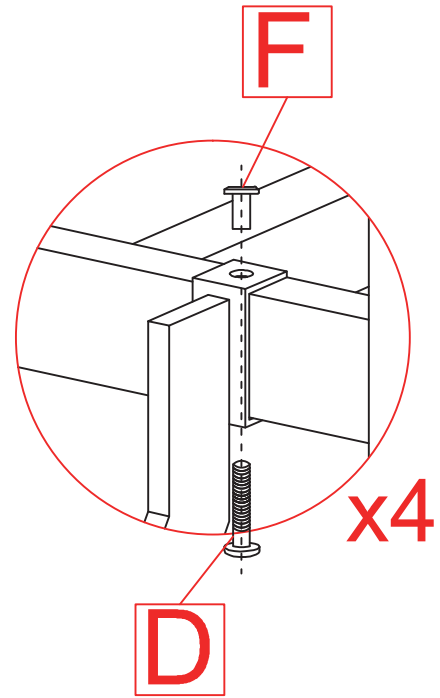
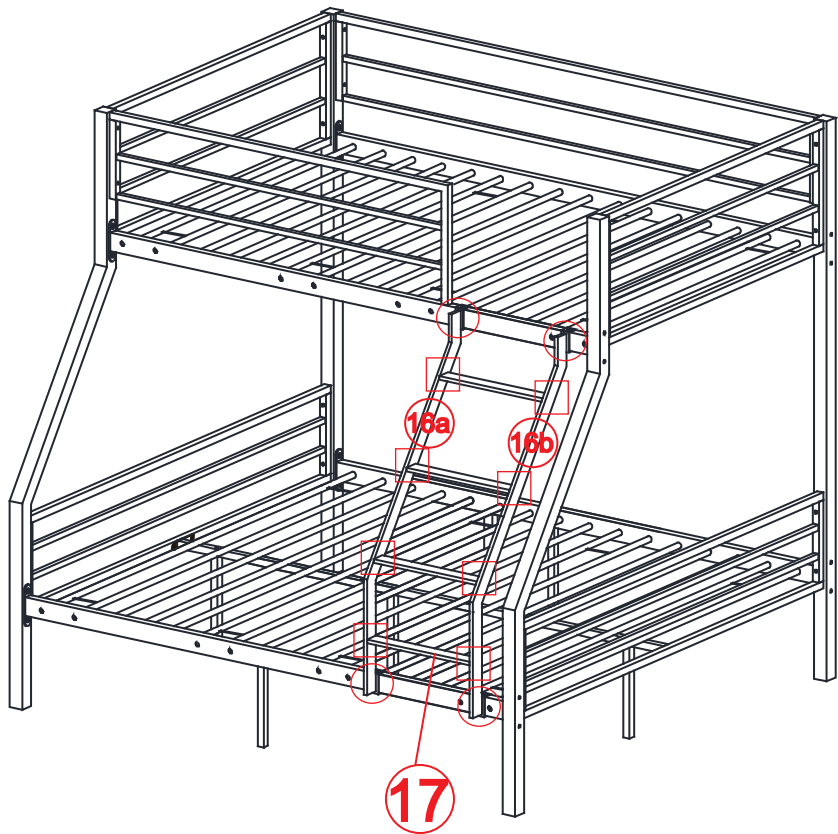

Assemble ladder



Assembly method:

Firstly, align U-shaped slot of ladder bracket (16a & 16b) with screw hole on the bed bar as shown in the figure, insert it upward from screw hole with M6x18 jcn nut (F). M6x45 screw (D) is screwed in and fixed upward from screw hole on the bottom of bed bar.

Don't tighten the screws. Then place the pedal (17) on the iron sheet with screw holes on the bracket (16a & 16b) and screw downward with M6x10 screw (A). After screwing all screws, tighten all screws on the bed frame in turn.

CODE	HARDWARE	QTY
A	 M6X10	8
D	 M6X45	4
F	 M6X18	4

## STEP 8

Assemble rubber mat on the ladder pedal

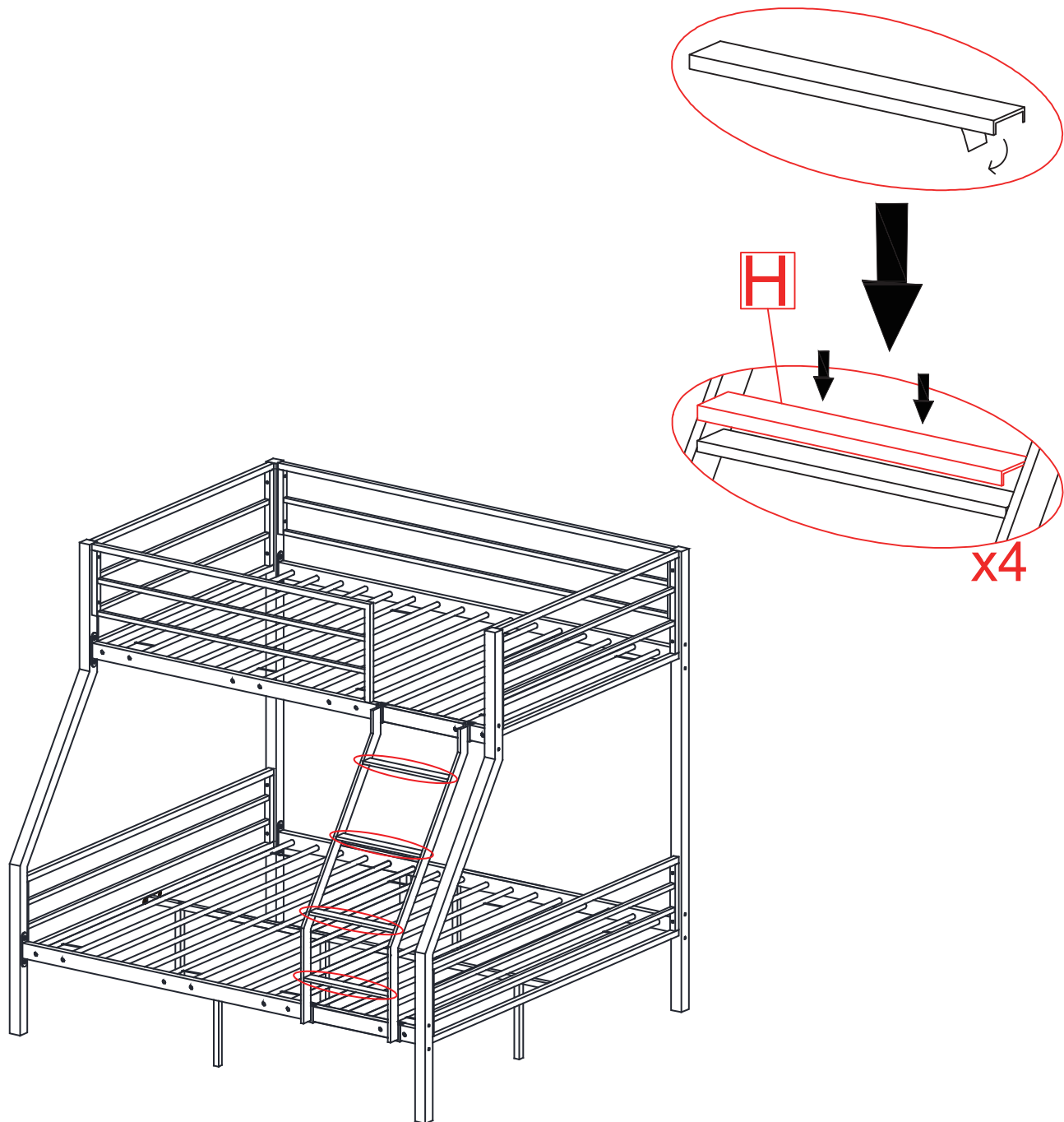

Assembly method:

Remove the oily paper on the back of Rubber Mat (H) and attach it to the ladder pedal directly and press it.

CODE	HARDWARE	QTY
H		4