

High Bay

Commercial High Bay Light



IP65

FIVE YEAR
5
WARRANTY



LED Commercial High Bay

Part Number	LOT-BAY-100-4	LOT-BAY-150-4	LOT-BAY-200-4
Lumen Output	11,669lm	17,042lm	20,818lm
Wattage	100W	150W	200W
Lumen Efficacy	121.19lm/W	114.68lm/W	107.2lm/W
CCT	5238K	5209K	5216K

Beam Angle	120°(90° optional)		
Input Voltage	100-277Vac PF 0.9826	100-277Vac PF 0.9945	100-277Vac PF 0.993
IP Rating	IP 65		
LED Driver	Meanwell		

Certification	UL, CE, PSE, SAA, RoHS		
---------------	------------------------	--	--

Details

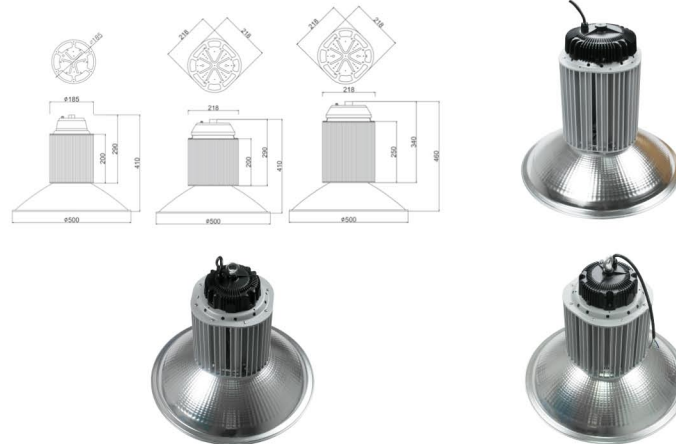

LED Technology

This LED High Bay Light can produce the best glare-free lighting for places such as warehouses, parking lots, stores, lobbies, offices, homes and restaurants. The general lifespan of this product is 60,600 hours. It is created with a built-in heat sink that provides great heat dissipation to ensure the light's lifespan. This product also operates with an excellent color consistency with its LM-80-rated LED chips. This product is also friendly with the environment, as it doesn't produce mercury and UV radiations.



www.lightingoftomorrow.com
1-800-538-4446

