

ALL IN ONE SOLAR LIGHT SPECIFICATION (GECKO SERIES)



SASO UN38.3 IP66



Black Pearl
Model Number: GK-1B

Parameters

Model No.	GK-1B
Light Wattage	30W
Luminous flux	1500 lm
Solar Panel:	Monocrystalline silicon 12W
Battery:	3.7V 20AH
LED Chip:	Seoul
Warranty:	2 Years
CCT :	5000k-6500k
Beam Angle:	160 degree
Backup Time	3 nights
Working Mode	First 4 hours full brightness, later 4 hours 50% brightness, last 4 hours 25% brightness
Working Temperature:	-20°C to 60°C
Charging Time:	9-11 hours
Requied Pole Size:	60 mm(top end)
Installations:	Pole/Square/Wall Mounting
Recommended Installation Height:	2.5 m

Features

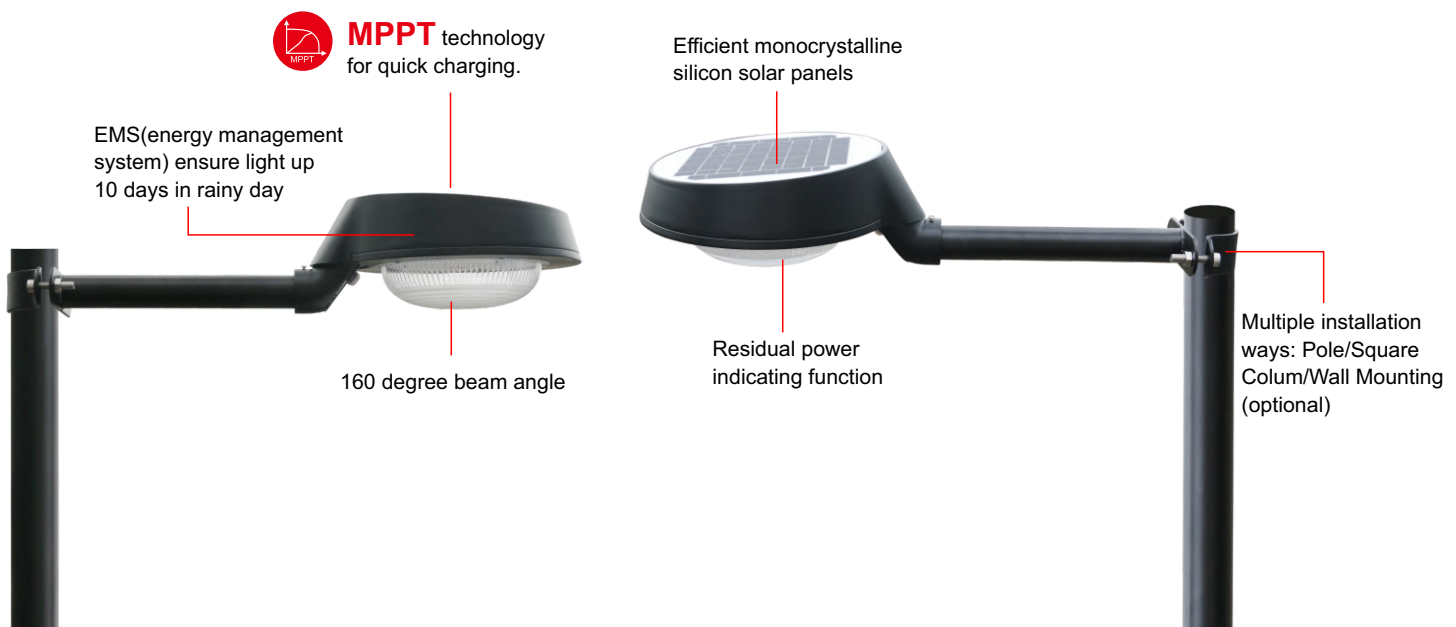

Products Size

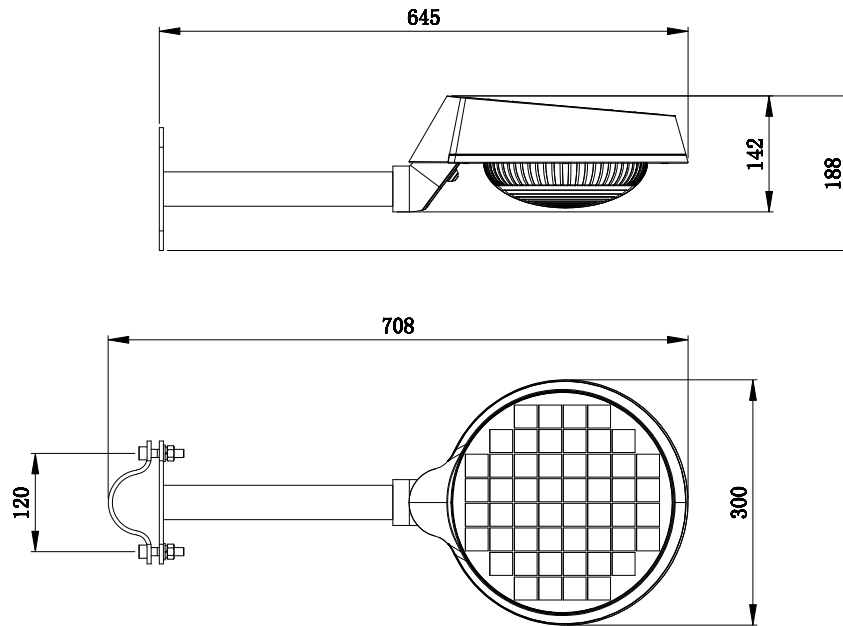

Applications

Widely used in the road, street, and factory, park road, rural, mountainous area and the remote area lighting project, courtyard, schools, square and other need to place.

