

## Back-lit LED panel light



### PRODUCT FEATURES:

- ❖ Optical design, greatly improved the light utilization and evenness.
- ❖ High efficiency LED Driver, voltage AC120-277.
- ❖ UL 1598 suitable for damp locations, Type IC.
- ❖ The 0-10V Dimming type is continuous.
- ❖ The product can dim to 10%.

MODEL #	
PROJECT:	
NOTES:	
DATE:	
PREPARED BY:	

### Additional Information:

- Power: 28W/36W
- Input: AC 120-277V
- CCT : 3500K/4000K/5000K
- Light Source:SMD 2835 LEDs
- Driver: XIEZHEN POWER



### PRODUCT APPLICATIONS:

The Back-lit LED panel Lighting Series can be widely used for Indoor Excellent for Offices, Hallways, Multipurpose Rooms , Office Buildings, Conference Rooms,super market, store and many other applications.

### Specifications

#### LPZ -22/24

Length:603MM/1213MM (23.7"/47.8")  
Width: 603MM (23.7")  
Depth:41MM (1.6")  
Weight:2.62/4.18(kg)

### Packaging information

- ❖ **22LPZ28W27-XXK**:660MMX222MMX653MM (4 Pcs/CTN)  
26.0"X8.7"X25.7"
- ❖ **24LPZ36W27-XXK**:1267MMX222MMX653MM (4 Pcs/CTN)  
50.0"X8.7"X25.7"

### Mounting

- ❖ Surface Mounting.
- ❖ Recessed lighting fixture

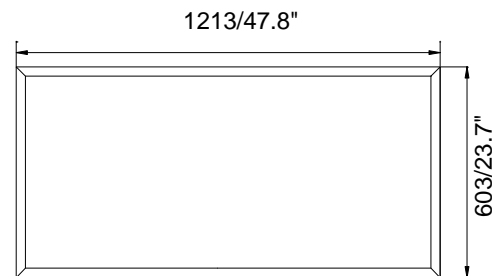
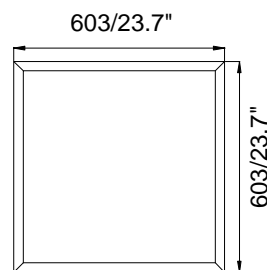

## Back-lit LED panel light

### TECHNICAL PARAMETERS:

Type	22LPZ28W27-XXK/24LPZ36W27-XXK		
Power	28W/36W	Lighting Angle	113°
Input Voltage	AC120-277V	LED Brightness Decay	<5%/6000 hrs
PF	>0.98	Working Life	>75000 hrs
Driver Efficiency	>90%	Working Temperature	-20 - +40°C
Luminous Flux	3451 Lm / 4758 Lm	Storage Temperature	-20 -+40°C
Color Temperature	3500K/4000K/5000K	Protection Level	Damp
CRI	Ra>80	Cable	Input Connect, No Cable

### PHOTOMETRY:

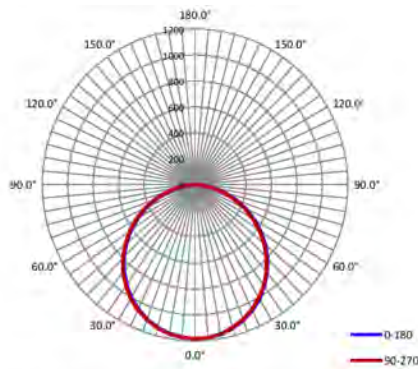

	C0/180	C45/225	C90/270	C135/315	AVG.
Beam Angle (50% I <sub>max</sub> ):	113.1	113.2	113.2	113.3	113.2
Field Angle (10% I <sub>max</sub> ):	162.6	162.6	162.6	162.7	162.6

CIE 1931 x y Chromaticity Diagram

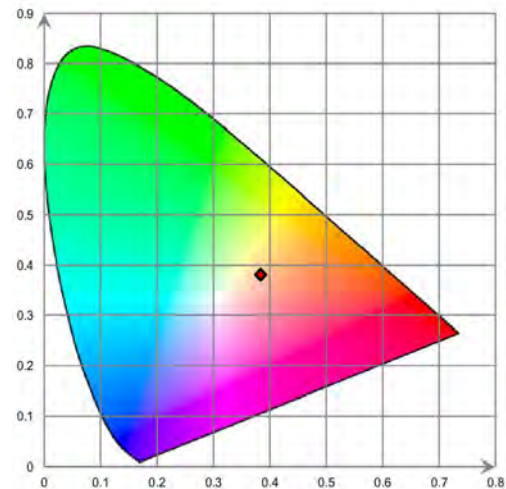

### ORDERING EXAMPLE:22LPZ28W27-XXK/24LPZ36W27-XXK

22	LPZ	28W	27	XXK
Size	Product	Power	Voltage	ColorTemp
22 (2X2feet) 24 (2X4feet)	LED Panel Lights	28W 28W(28W) 36W(36W)	27 AC120-277V	35K (3500K) 40K (4000K) 50K (5000K)

## Back-lit LED panel light

### Accessories

Emergency Kits		Charging: 24hours		
		Back up: 90minutes		
		Power: 6Watts		

### (1) Dimensions:

17.7"x1.26"x0.83"(450mmx32mmx21mm)

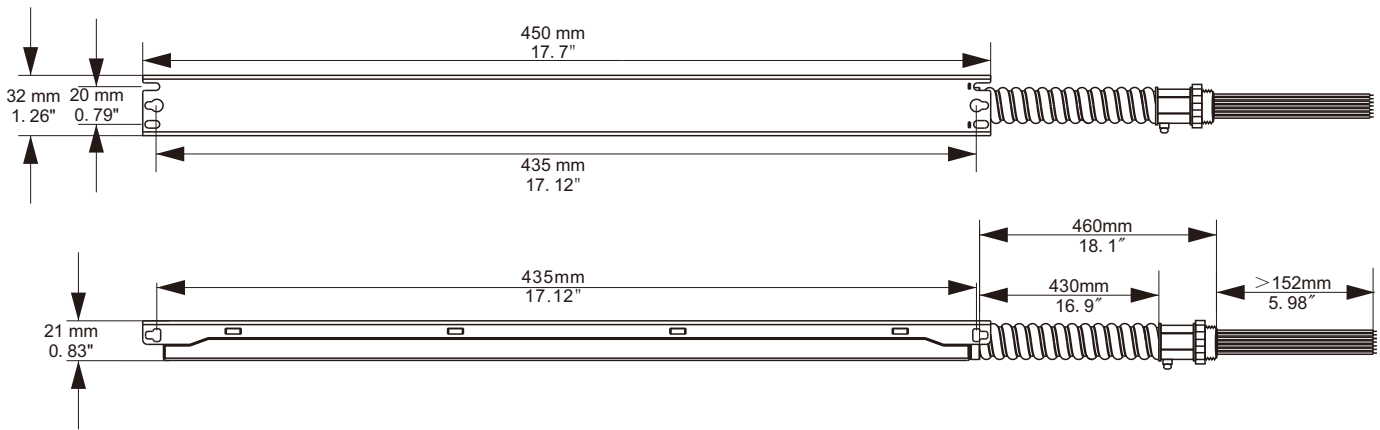

### (2) Specifications:

Input Voltage	100-277Vac 50/60Hz	Temperature Rating (Ambient)	0°C to +50°C (32°F to 122°F)		LECP-YT0008-025/048	LECP-YT0015-025/048	LECP-YT0020-025/048
AC Input Current	100mA max.	Output Voltage	25V-48Vdc	Emergency time	90 minutes	90 minutes	90 minutes
AC Input Power	7.0W max.	Charging Current	≤250mA	Output Power	8W	15W	20W
Full Warranty	5 Years	Charging Time	≥24Hours	Battery (Li-ion battery)	11.1V/2000mAh	14.8V/2000mAh	14.8V/2500mAh

### Wiring Diagram:

