



# 20 Gallon Air Compressor

## Owner's Manual



**Model No. PCFG200**

**For Service Please Call Toll Free. 1-866-591-8921**

### **⚠ WARNING ⚠**

Read and follow all safety rules and instructions in this manual before attempting to operate this machine. Failure to comply with these instructions may result in personal injury.

Diagrams within this manual may not be drawn proportionally. Due to continuing improvements, the actual product may differ slightly from the product described herein.

# Air Compressor

## SPECIFICATIONS TABLE

Maximum Air Pressure	115 PSI
Air Tank Capacity	20 Gallons
Air Flow Capacity	6.2 CFM at 40 PSI 5.2 CFM at 90 PSI
Motor	2.5 HP Working / 4 HP Peak 120 Volt / 60 Hz / 13 A / 1-Phase
Required Circuit	Minimum 20 Amp <b>*Dedicated</b>
Pump Stage	Single
Air Outlet Size	1/4" - 18 NPT
Accessories	Air Intake Filter; Air Hose Coupler

\*A dedicated circuit is used only for a single load, for this compressor. Other loads on the circuit must be disconnected or turned off when the compressor is plugged in.

## SAVE THIS MANUAL

You will need this manual for the safety warnings and precautions, assembly, operating, inspection, maintenance and cleaning procedures, parts list and assembly diagram. Keep your invoice with this manual. Write the invoice number on the inside of the front cover. Keep this manual and invoice in a safe and dry place for future reference.

## GENERAL SAFETY WARNINGS AND PRECAUTIONS

1. **KEEP WORK AREA CLEAN AND DRY.** Cluttered, damp, or wet work areas invite injuries.
2. **KEEP CHILDREN AWAY FROM WORK AREA.** Do not allow children to handle this product.
3. **KEEP IDLE EQUIPMENT.** When not in use, tools and equipment should be kept in a dry location to inhibit rust. Always lock up tools and equipment, and keep out of reach of children.
4. **DO NOT USE THIS PRODUCT IF UNDER THE INFLUENCE OF ALCOHOL OR DRUGS.** Read warning labels on prescriptions to determine if your judgement or reflexes are impaired while taking drugs. If there is any doubt, do not attempt to use this product.
5. **USE EYE AND HAND PROTECTION.** Wear ANSI-approved safety impact goggles and heavy-duty work gloves when using this product. ANSI-approved safety impact eyeglasses and heavy-duty work gloves are available from Harbor Freight Tools.
6. **DRESS SAFELY.** Do not wear loose clothing or jewelry, as they can become caught in moving parts. Wear a protective hair covering to prevent long hair from becoming caught in moving parts. If wearing a long-sleeve shirt, roll sleeves up above elbows.

---

# Owner's Manual

---

7. **DO NOT OVERREACH.** Keep proper footing and balance at all times to prevent tripping, falling, back injury, etcetera.
8. **INDUSTRIAL APPLICATIONS MUST FOLLOW OSHA REQUIREMENTS.**
9. **STAY ALERT.** Watch what you are doing at all times. Use common sense. Do not use this product when you are tired or distracted from the job at hand.
10. **CHECK FOR DAMAGED PARTS.** Before using this product, carefully check that it will operate properly and perform its intended function. Check for damaged parts and any other conditions that may affect the operation of this product. Replace or repair damaged or worn parts immediately.
11. **REPLACEMENT PARTS AND ACCESSORIES:** When servicing, use only identical replacement parts. Only use accessories intended for use with this product. Approved accessories are available from Harbor Freight Tools.
12. **MAINTAIN THIS PRODUCT WITH CARE.** Keep this product clean and dry for better and safer performance.
13. **MAINTENANCE:** For your safety, service and maintenance should be performed regularly by a qualified technician please call Toll Free: 1-866-591-8921
14. **USE THE RIGHT TOOL FOR THE JOB.** Do not attempt to force a small tool or attachment to do the work of a larger industrial tool. There are certain applications for which this tool was designed. It will do the job better and more safely at the rate for which it was intended. Do not modify this tool, and do not use this tool for a purpose for which it was not intended.
15. **WARNING:** The warnings, precautions, and instructions discussed in this manual cannot cover all possible conditions and situations that may occur. The operator must understand that common sense and caution are factors, which cannot be built into this product, but must be supplied by the operator.

---

# Owner's Manual

---

## SPECIFIC PRODUCT WARNINGS AND PRECAUTIONS

1. **WARNING:** Make sure to fill the Air Compressor with a premium quality, 30-weight, non-detergent compressor oil before each use. Running the Air Compressor with no oil or low oil will cause damage to the equipment. **Note:** The oil reservoir has an optimal capacity of 30 ounces of oil.
2. **WHEN CHECKING THE OIL LEVEL:** Make sure to **unscrew** (do not pull) the Breather Valve (14B) out. **(See Figure C, and Assy. Diagram B.)**
3. **MAKE SURE ALL TOOLS AND EQUIPMENT USED WITH THE AIR COMPRESSOR ARE RATED TO THE APPROPRIATE CAPACITY.** Do not use any tool or equipment that does not operate from 0 to 115 PSI.
4. **DRAIN AIR COMPRESSOR EVERY DAY.** Do not allow moisture to build up inside the Air Compressor. **(See "INSPECTION, MAINTENANCE, AND CLEANING" section of this manual.)**
5. **MAINTAIN A SAFE WORKING ENVIRONMENT.** Keep the work area well lit. Make sure there is adequate surrounding workspace. Always keep the work area free of obstructions, grease, oil, trash, and other debris. Do not use the Air Compressor in areas near flammable chemicals, dusts, and vapors.
6. **AVOID INJURY:** Never direct the Air Flow Valve (6A) at people or animals. **(See Assy. Diagram A.)**
7. **DO NOT ALTER OR REMOVE THE FACTORY SEALED PRESSURE RELEASE VALVE (5A).** **(See Assy. Diagram A.)**
8. **DO NOT OPEN THE WATER DRAIN VALVE (10A) SO THAT MORE THAN FOUR THREADS ARE SHOWING.** **(See Assy. Diagram A.)**
9. **AN EXTENSION CORD MUST NEVER BE USED WITH THIS ITEM.** **Connecting this item to an outlet through an extension cord MAY CAUSE ELECTRICAL DAMAGE TO THE MOTOR and could present a FIRE HAZARD.**
10. **THIS COMPRESSOR MAY REQUIRE A DEDICATED ELECTRICAL CIRCUIT AS THE AMPERAGE DRAW UNDER FULL LOAD COMBINED WITH USE OF ANY OTHER ITEM MAY OVERLOAD YOUR CIRCUIT.**
11. **WARNING:** This product contains or produces a chemical known to the State of California to cause cancer and birth defects (or other reproductive harm). (California Health & Safety Code § 25249.5, *et seq.*)
12. **WARNING:** People with pacemakers should consult their physician(s) before using this product. Operation of electrical equipment in close proximity to a heart pacemaker could cause interference to or failure of the pacemaker.

# Owner's Manual

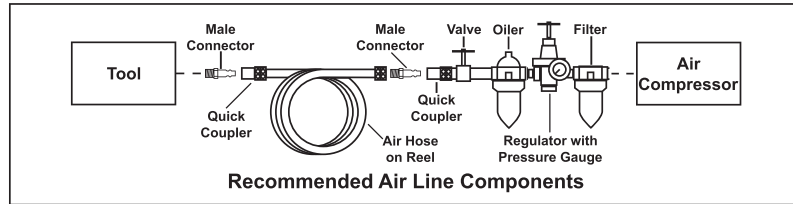

**TO EXTEND THE LIFE OF YOUR AIR TOOLS AND EQUIPMENT**, it is recommended to install an oiler and water filter in series with the Air Output Line of the Air Compressor.

## UNPACKING

When unpacking, check to make sure all the parts shown on the **Parts Lists on pages 9, and 10** are included. If any parts are missing or broken, please call our service department Toll Free 1-866-591-8921 as soon as possible.

**IMPORTANT!** This compressor is shipped with the oil fill plug removed and without oil. The oil fill plug is attached to the power cord as a reminder to add oil to the crankcase. Add oil to the proper level as explained below and secure the oil fill plug before use.

## OPERATING INSTRUCTIONS

**NOTE:** For additional references to the parts listed below, refer to the **Assembly Diagrams on pages 9, and 10**.

### To Check The Oil Level:

1. The Oil Window (20B) is used to determine if oil is needed. The oil level should always be at the maximum level (red line on the Oil Window). (See Figure C, and Assy. Diagram B.)

# Owner's Manual

2. If necessary, add a *premium quality, 30-weight, non-detergent compressor oil* into the Oil Fill Hole until the level of oil reaches the maximum level as indicated on the Oil Window (20B). The optimal capacity of the oil reservoir is 30 ounces. Do not overfill. Then thread the Breather Valve back into the Oil Fill Hole, being careful not to strip the plastic threads. (See Figure C, and Assy. Diagram B.)

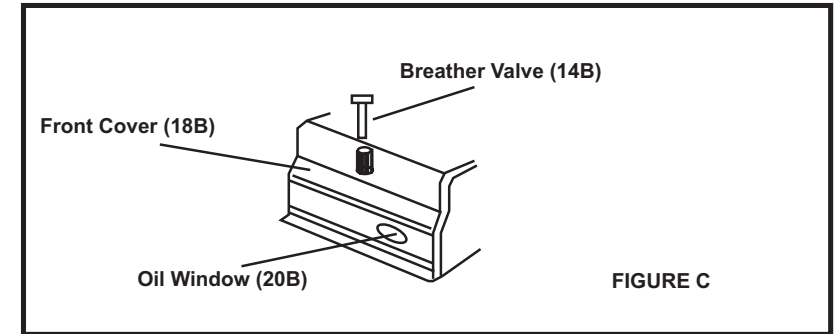

FIGURE C

### To Turn The Air Compressor On:

1. Check to make sure the Water Drain Valve (10A) is fully closed.
2. Turn the Air Flow Valve (6A) to its "OFF" position.
3. Connect the air hose (not provided) to the Air Flow Valve (6A) of the Air Compressor. Then, connect the other end of the air hose to the pneumatic tool (not provided) that is to be used.
4. **Note: Always plug the Power Cord of the Air Compressor into a 115 V- electrical source ( $\pm 10\%$  maximum variation).**
5. Rotate the "ON/OFF" Power Switch (1A) to the horizontal position to turn the Air Compressor **on**. (Rotate the "ON/OFF" Power Switch (1A) to the vertical position to turn the Air Compressor **off**.)
6. Allow sufficient time for the Tank Pressure Gauge (4A) to indicate **80 PSI** before using the Air Compressor.
7. Turn the Air Flow Valve (6A) to its "ON" position to allow air to the pneumatic tool.

---

# Owner's Manual

---

8. **NOTE:** With the Air Compressor turned on, the operation is automatic and under the control of the automatic switches inside the box under the Power Switch (1A). **NEVER open the power switch box or adjust the controls within.**

### **To Adjust The Air Output To The Pneumatic Tool:**

1. **NOTE:** When adjusting the air pressure being forwarded to the pneumatic tool, you will need to compare the pressure readings of both the Tank Pressure Gauge (3A) and the Tool Pressure Gauge (4A). The reading on the Tank Pressure Gauge dictates the maximum/minimum air pressure at which the Tool Pressure Gauge may also be set.
2. With the Air Compressor running, and the air hose and pneumatic tool hooked up to the Air Compressor, pull up on the Tool Pressure Adjuster (2A). Turn the Tool Pressure Adjuster **clockwise to increase** the air output to the tool, up to the working air pressure (115 PSI) as indicated on the Tank Pressure Gauge (3A).
3. Turn the Tool Pressure Adjuster (2A) **counterclockwise to decrease** the air output to the tool, down to the minimum rated pressure (0 PSI) as indicated on the Tank Pressure Gauge (3A).

### **To Use The Tank Pressure Relief Valve:**

1. The Tank Pressure Relief Valve Ring (5A) is used when decompression is needed quickly and efficiently.
2. To decompress the Air Tank (9A) pressure, rotate the "ON/OFF" Power Switch (1A) up to the vertical position to turn off the Air Compressor.
3. Pull out on the Tank Pressure Relief Valve Ring (5A) to immediately release air pressure in the Air Tank (9A).

### **To Empty Air And Condensation From The Tank:**

1. The Water Drain Valve (10A) is located underneath the Air Tank (9A), and should be used daily to release all trapped moisture through this valve. The Water Drain Valve will also eliminate condensation that may cause Air Tank corrosion.
2. **WARNING: Do not open the Water Drain Valve (10A) so that more than four threads are showing.**
3. Rotate the "ON/OFF" Power Switch (1A) up to the vertical position to turn off the Air Compressor. Then, unplug the Air Compressor's Power Cord from the electrical outlet.
4. Slowly and carefully unscrew (no more than four threads) the Water Drain Valve (10A) until the compressed air and condensation begins to be released from the Air Tank (9A). Allow sufficient time for all of the air and condensation to escape from the Air Tank. Then, firmly retighten the Water Drain Valve.

---

# Owner's Manual

---

### **Reference: Overload Switch (35B)**

The overload breaker will trip if an over-current condition is sensed, stopping the motor. If this occurs, shut off the pressure switch and wait at least 5 minutes.

Release the air pressure in the tank to ease restarting. Then press the breaker button to reset it, and turn on the pressure switch.

### **INSPECTION, MAINTENANCE, AND CLEANING**

1. **CAUTION:** Always disconnect the Air Compressor from its electrical supply source before performing any inspection, maintenance, or cleaning.
2. **BEFORE EACH USE,** inspect the general condition of the Air Compressor. Check all air fittings for leaks. Check for loose screws, misalignment or binding of moving parts, cracked or broken parts, damaged power cord and plug, and any other condition that may affect the safe operation of this tool. If abnormal noise or vibration occurs, immediately disconnect the Air Compressor from its electrical supply source and have the problem corrected before further use.  
**Do not use damaged equipment.**
3. **DAILY:** Check the Air Compressor oil level. If necessary, fill with a premium quality, 30-weight, non-detergent compressor oil. **NOTE:** When checking the oil level, make sure to **unscrew** (do not pull) the Breather Valve (14B).
4. **DAILY:** Purge the Air Tank (9A) of all air and moisture to prevent corrosion. To do so, slowly and carefully unscrew (no more than four threads) the Water Drain Valve (10A) until the compressed air and condensation begins to be released from the Air Tank. Allow sufficient time for all of the air and condensation to escape from the Air Tank. Then, firmly retighten the Water Drain Valve.
5. **EVERY 100 HOURS OF USE:** Clean the Air Filter (7A) with a mild solvent. Then, dry and reattach the Air Filter. **NOTE:** Replace the Air Filter if it is too dirty to properly clean.
6. **EVERY 500 HOURS OR 12 MONTHS:** Replace the old oil with new, premium quality, 30-weight, non-detergent compressor oil.
7. **TO CLEAN:** wipe with a damp cloth, using a mild detergent or mild solvent.
8. **WHEN STORING:** Keep the Air Compressor in a clean, dry location.

# Owner's Manual

## PARTS LIST A / ASSEMBLY DIAGRAM A

Part	Description	Qty.	Part	Description	Qty.
1A	ON/OFF Power Switch	1	11A	Quick Connect Coupler	1
2A	Tool Pressure Adjuster	1	12A	Rubber Wheel with Bolt	2
3A	Tank Pressure Gauge	1	13A	Washer	2
4A	Tool Pressure Gauge	1	14A	Nut	2
5A	Pressure Release Valve	1	15A		
6A	Air Flow Valve	1	16A	Oil Drain Plug with Gasket	1
7A	Air Filter	1	17A	Foot	2
8A	Air Flow Lid	1	18A	Unloader Valve	1
9A	Air Tank	1	19A	Polyurethane Unloader Tube	1
10A	Water Drain Valve	1	20A	Copper Air Tube	1

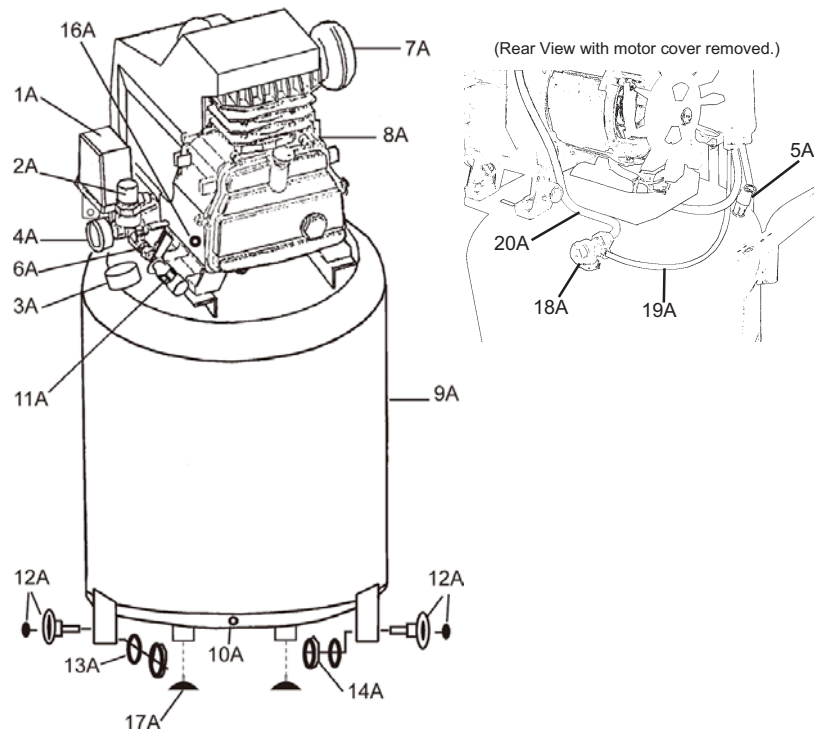

# Owner's Manual

## PARTS LIST B / ASSEMBLY DIAGRAM B

Part	Description	Qty.	Part	Description	Qty.
1B	Bolt	4	19B	Gasket	1
2B	Cylinder Case	1	20B	Oil Window	1
3B	Gasket	1	21B	Crankshaft Bolt	1
4B	Valve Seat	1	22B	Crankshaft	1
5B	Gasket	1	23B	Crankshaft Case	1
6B	Cylinder	1	24B*	Stator	1
7B	Compression Ring	2	25B*	Bearing	2
8B	Oil Scraping Ring	1	26B*	Armature	1
9B	Piston	1	27B	Capacitor, 120uF±5%	1
10B	Gasket	1	28B	Radiating Fan Wheel	1
11B	Piston Pin	1	29B	Retainer Ring	1
12B*	End Cover	1	30B	Bolt	4
13B	Crankshaft Retainer	2	31B	Screw	2
14B	Breather Valve	1	32B	Radiating Cover	1
15B	Connecting Rod	1	33B*	Seal Washer	1
16B	Gasket	1	34B	Motor Assembly	1
17B	Bolt	6	35B	Overload Switch	1
18B	Front Cover	1			

\*Not available individually. Must be ordered as entire Motor Assembly (See part #34B).

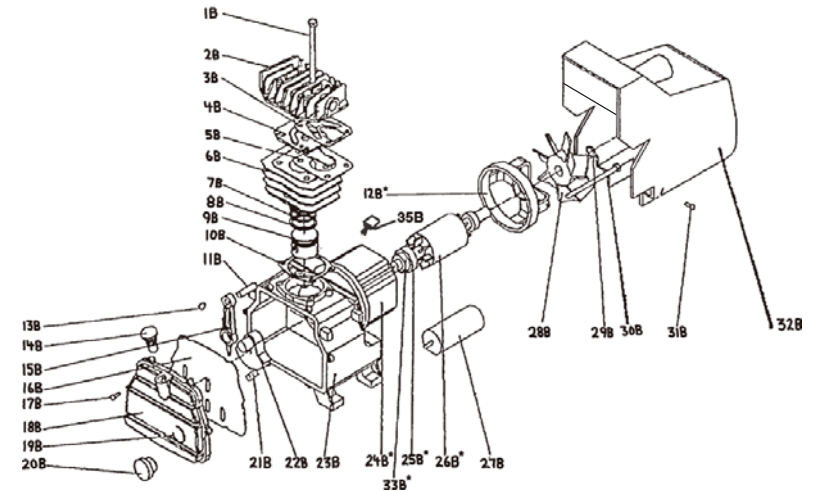

**NOTE:** Some parts are listed and shown for illustration purposes only, and are not available individually as replacement parts.

---

# Owner's Manual

---

## LIMITED WARRANTY

Pulsar Products, Inc. warrants to the original purchaser who uses the product in a consumer application (personal, residential or household usage) that all products covered under this warranty are free from defects in material and workmanship for one year from the date of purchase. All products covered by this limited warranty which are used in commercial applications (i.e. income producing) are warranted to be free of defects in material and workmanship for 90 days from the date of original purchase. Products covered under this warranty include air compressors, air tools, service parts, pressure washers and generators. Pulsar Products, Inc. will repair or replace at Pulsar Products, Inc. sole option, products or components which have failed within the warranty period. Service will be scheduled according to the normal work flow and business hours at the service center location, and the availability of replacement parts. All decisions of Pulsar Products, Inc. with regard to this limited warranty shall be final. This warranty gives you specific legal rights, and you may also have other rights which vary from state to state.

### RESPONSIBILITY OF ORIGINAL PURCHASER (Initial User):

To process a warranty claim on this product, DO NOT return item to the retailer. The product must be evaluated by an Authorized Warranty Service Center. For the location of the nearest Authorized Warranty Service Center contact the retailer or place of purchase. Retain original cash register sales receipt as proof of purchase for warranty work.

Use reasonable care in the operation and maintenance of the product as described in the Owner's Manual(s).

Deliver or ship the product to the nearest Authorized Warranty Service Center. Freight costs, if any, must be paid by the purchaser.

Air compressors with 60 and 80 gallon tanks will be inspected at the site of installation.

Contact the nearest Authorized Warranty Service Center that provides on-site service calls for service call arrangements.

If the purchaser does not receive satisfactory results from the Authorized Warranty Service Center, the purchaser should contact Pulsar Products, Inc..

---

# Owner's Manual

---

## LIMITED WARRANTY (cont'd)

### THIS WARRANTY DOES NOT COVER:

Merchandise sold as reconditioned, used as rental equipment, or floor or display models.

Merchandise that has become damaged or inoperative because of ordinary wear, misuse, cold, heat, rain, excessive humidity, freeze damage, use of improper chemicals, negligence, accident, failure to operate the product in accordance with the instructions provided in the Owner's Manual(s) supplied with the product, improper maintenance, the use of accessories or attachments not recommended by Pulsar Products, Inc., or unauthorized repair or alterations.

Repair and transportation costs of merchandise determined not to be defective. Costs associated with assembly, required oil, adjustments or other installation and start-up costs.

Expendable parts or accessories supplied with the product which are expected to become inoperative or unusable after a reasonable period of use.

Merchandise sold by Pulsar Products, Inc. which has been manufactured by and identified as the product of another company, such as gasoline engines. The product manufacturer's warranty, if any, will apply.

ANY INCIDENTAL, INDIRECT OR CONSEQUENTIAL LOSS, DAMAGE, OR EXPENSE THAT MAY RESULT FROM ANY DEFECTS, FAILURE OR MALFUNCTION OF THE PRODUCT IS NOT COVERED BY THIS WARRANTY. Some states do not allow the exclusion, so it may not apply to you. IMPLIED WARRANTIES, INCLUDING THOSE OF MERCHANTABILITY OR FITNESS FOR A PARTICULAR PURPOSE, ARE LIMITED TO ONE YEAR FROM THE DATE OF ORIGINAL PURCHASE. Some states do not allow limitations on how long an implied warranty lasts, so the above limitations may not apply.