

## General System Layout Sketch

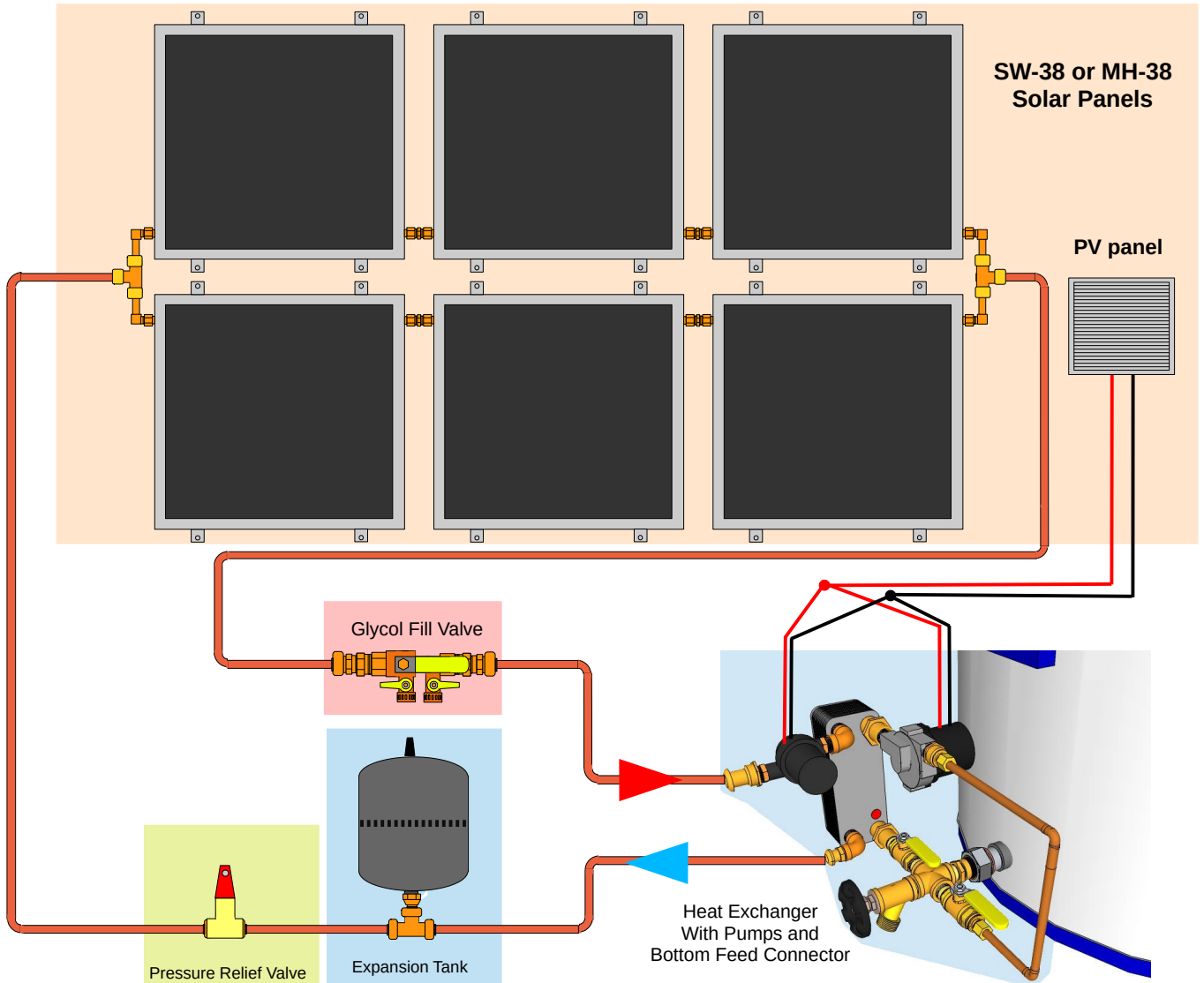



### Introduction

This document describes how to install a Heliatos freeze protected solar water heating system. These systems use SW-38 Solar Water Heating Panels in combination with a Stainless Steel heat exchanger. The circulation loop contains a freeze resistant non-toxic fluid. As a result there is no danger of the panels freezing and being damaged. The kit includes Dowfrost™ food rated glycol concentrate. It has to be diluted depending on the level of freeze protection required in your area. The SW series panels are designed to be easily installed on any flat surface. They are equipped with 3/8" compression fittings so making reliable tight connections between panels and to standard 1/2" pipe or PEX is easy and fast. No soldering or special tools are required.

**It is the installer's responsibility to assure that the panels themselves as well as the method and place of installation are in full compliance with all applicable regulations. Please consult the datasheet for the panels you are considering and assure that they are permissible and appropriate for your location.**

### Surface Preparation and PV Panel Location

In general, the surface you are planning to use for your installation should be fairly flat. Our panels are unique in that they can accommodate a base that is up to 1/4" uneven under each panel. Because of the special polycarbonate glazing they can flex a small amount without damage. The panels are equipped with four "feet". Each foot has a hole that is sized for a #8 deck screw. If you are mounting the panels to a surface that is suitable for using exterior deck screws, they are ready to install out of the box. However, if you require bigger bolts, you will have to enlarge the holes with a drill. Do not make the holes larger than 1/4", as the feet will not have sufficient strength to hold the panels down.

If you are using a rack to tilt your panels towards the sun, please make sure the feet all rest flat on the surfaces of the rack and all feet are securely fastened to the rack. Rack mounted panels can be subject to large wind forces.

The PV (electric) panel that powers the pumps should be installed such that it gets the same sun as the water heating panels. This assures that the pumping power and heating are balanced. The two pumps are connected to the PV panel with the included wire. They are not interchangeable so please follow the instructions closely when installing the pumps.

## Step 1

Unpack the panels from the box and lay them on the installation surface next to each other. Each panel is connected to the next with a compression union. The compression nuts that are pre-installed onto the tube in the panels thread onto the two ends of these unions.

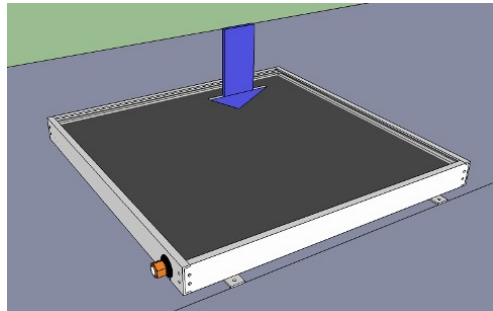

## Step 2

In this step you connect the panels to each other. The connection is formed by the included compression unions. First some sealant has to be applied to the union. You should put a ring of sealant around the inside lip of both sides of the union as shown in the illustration.

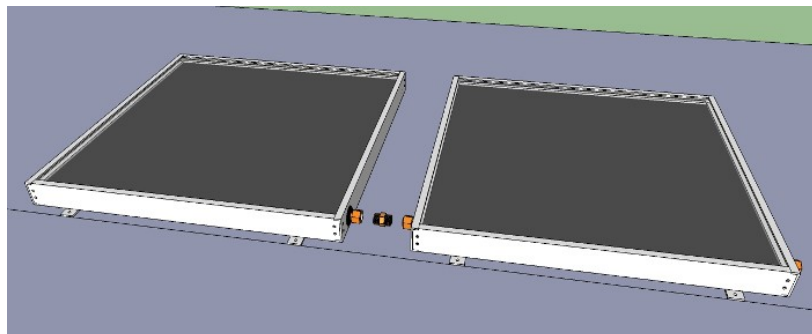
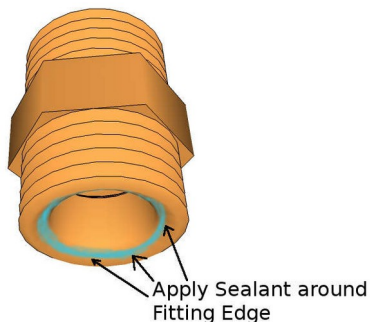

Start threading the union into the nuts on one panel and hand tighten only to allow some flexibility when lining up the panels. Bring the panels close to each other so the nuts on the second panel can be threaded onto the union, hand tighten. Slightly tighten the nuts on both sides. Not much torque is needed to form a tight seal. Once the system is pressurized you can tighten until all leaking stops.

## Freeze Protected System Installation Instructions (2-Row)

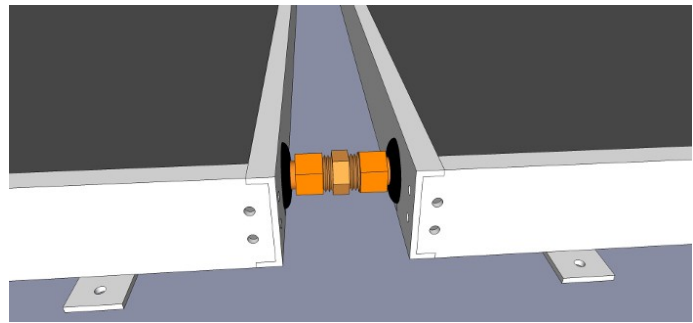
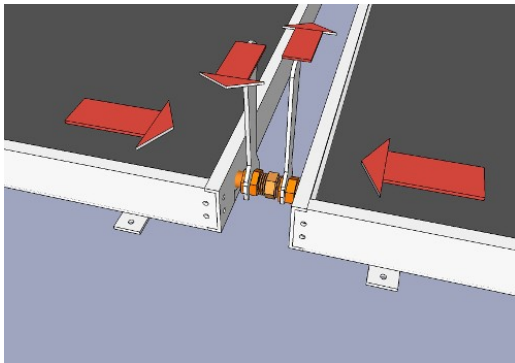

Repeat steps 1 and 2 for all your panels forming 2 rows

### NOTE ARRANGEMENT OF FITTINGS



### Step 3

It is important not to have the panels fastened down yet so they can be moved slightly to be able to complete this step.

You can use 1/2" copper or 1/2" CTS CPVC pipe or 1/2" PEX tubing. No soldering is required even if you are using copper pipe.

Your fittings kit includes a set of "two row adapters". They are used to connect the two rows to each other and to the input and output pipes for the array. Thread the adapters into the sides of the rows as shown in the pictures, apply sealant as in step 2 and hand tighten.

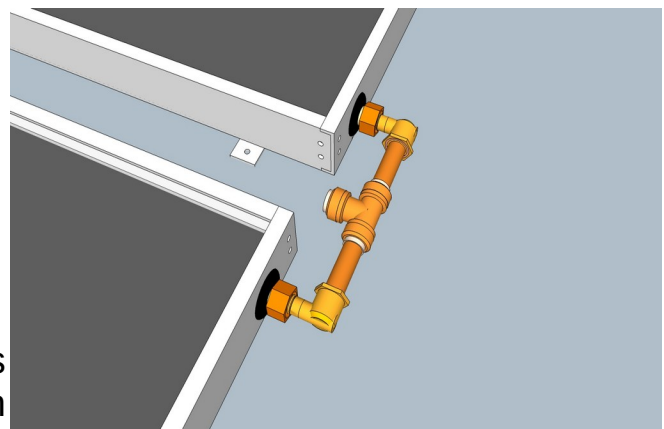

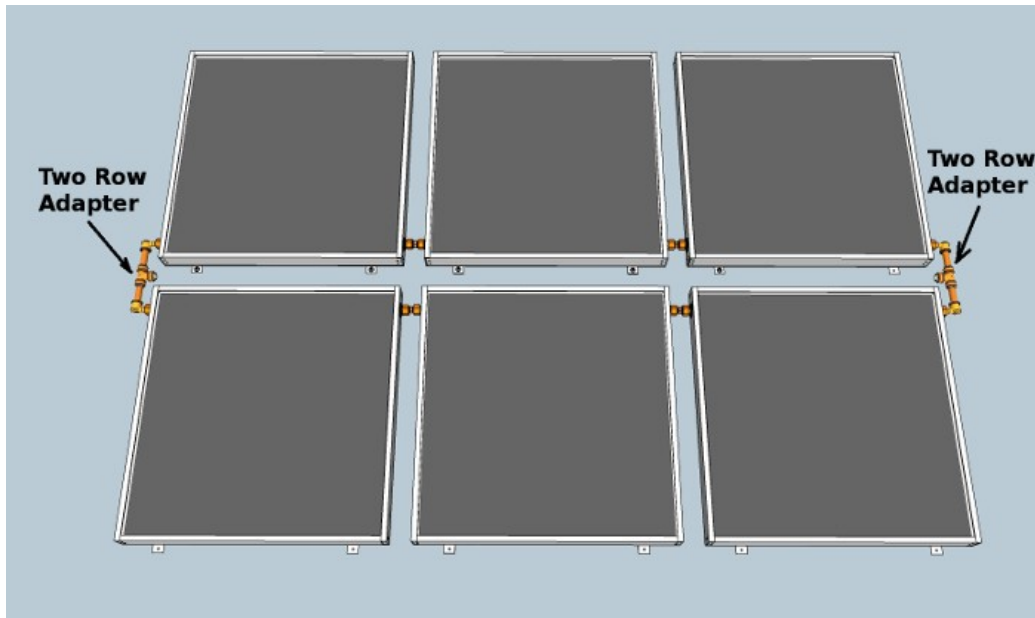

## Step 4

The two row adapters are equipped with a push-fit tee in the middle. Connecting a pipe is accomplished by simply pushing it into the opening as far as possible making sure it cannot come out again.

Now it is time to connect the pipes that go from the array to the water heater. The next diagram shows these fed through the roof (or rack) in the center of the array. However it is possible to turn the tees on the “two row adapters” in any direction to have the input and output pipes arranged differently.

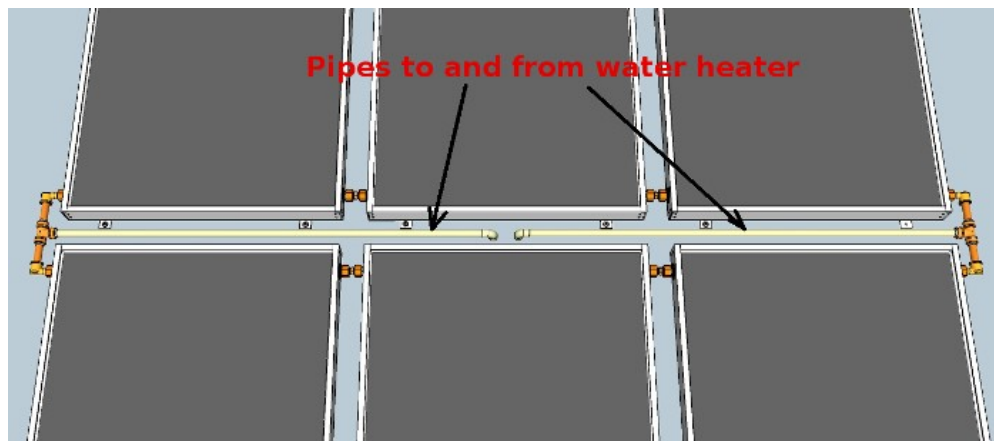

## Step 6

The panel array has to be securely tied down. This is especially true if it is mounted on a rack or on rails so that wind can catch the panels from below. We show a simple set of deck screws here, but depending what method you are planning to use you should follow the directions provided with your mounting hardware.

Please remember that these panels are very light so that under no circumstances can you rely on their weight to hold them in place.

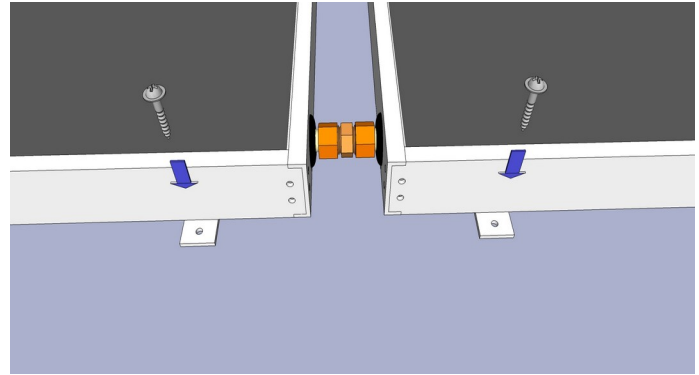

**To achieve full wind loading capability it is important to attach all tabs securely to your mounting system.**

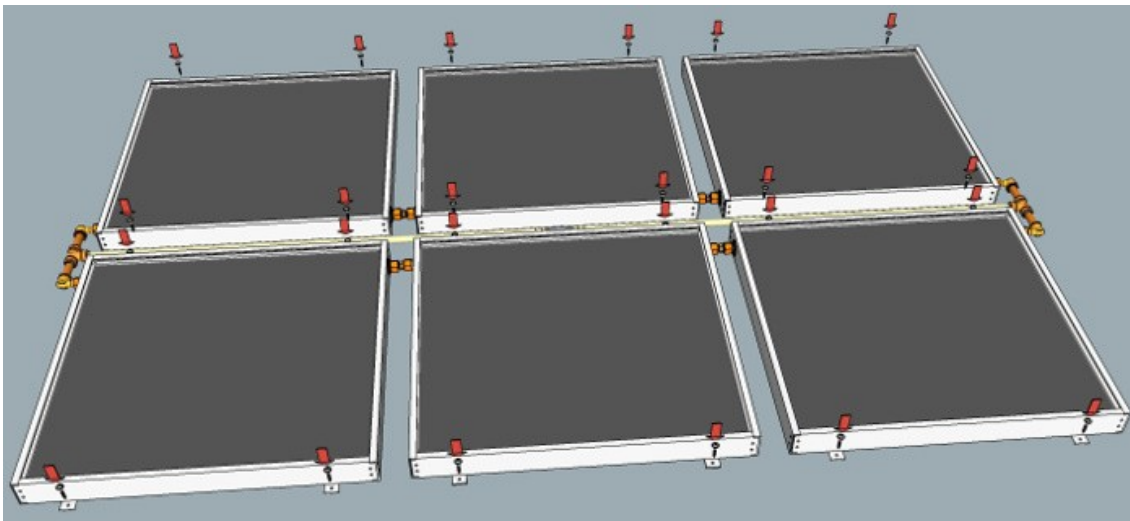

## Step 7

The exposed fittings and pipes have to be insulated next. This can be done by surrounding each joint with a foam or fiberglass sleeve. If you are using plastic foam a piece of aluminum adhesive tape should be wrapped around the foam sleeve to prevent rapid UV degradation.

## Freeze Protected System Installation Instructions (2-Row)

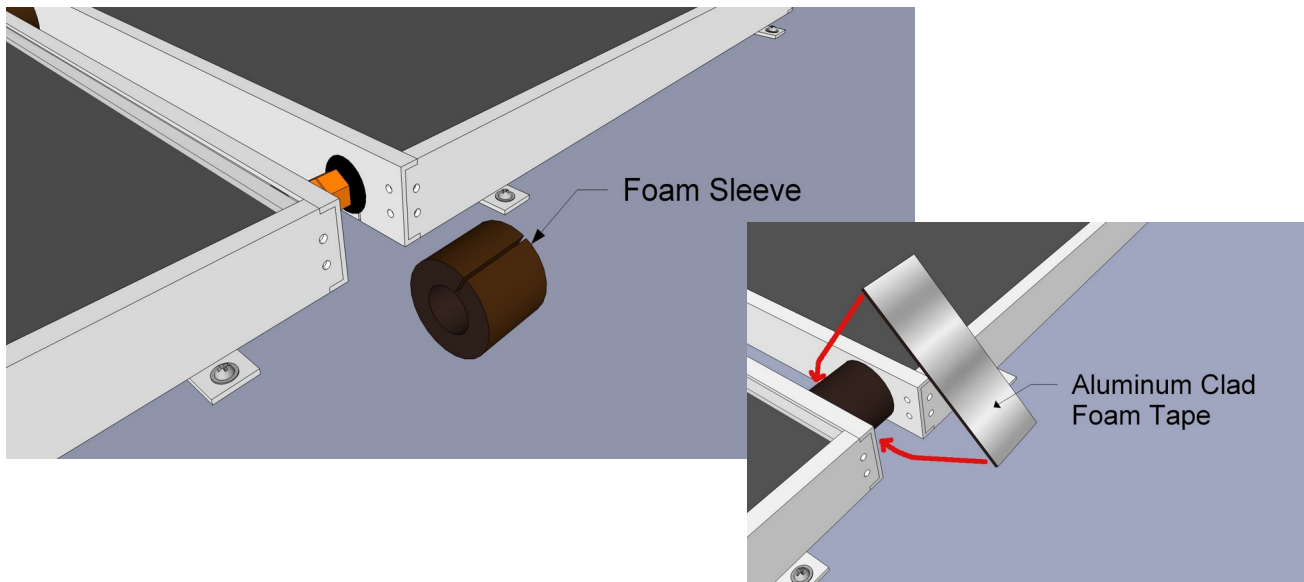

Install a foam sleeve over every fitting between panels as well as on the two row adapters and ALL pipe between the water heater and the panel array.

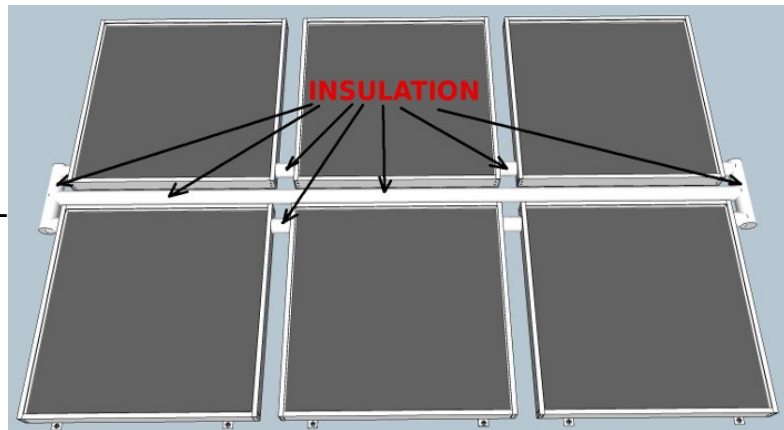

### Completed Array Installation

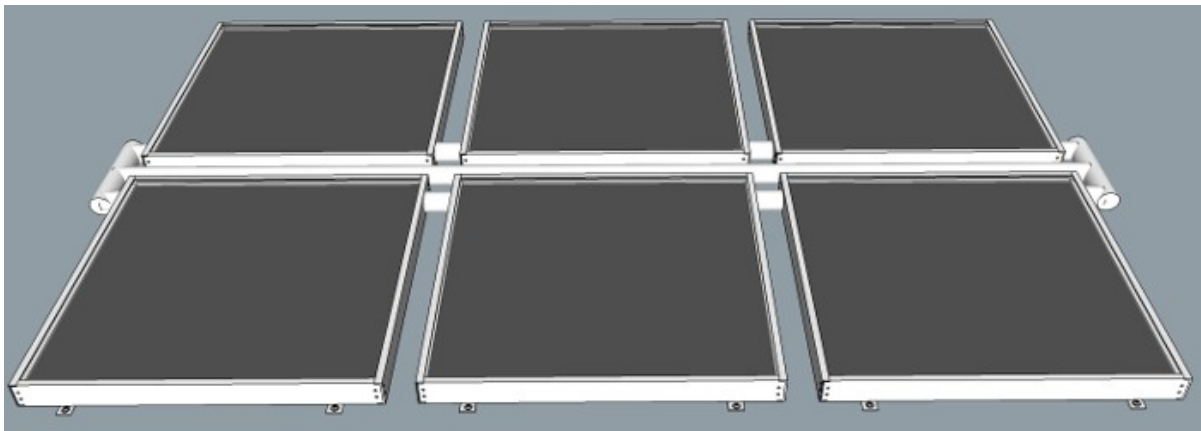



## Bottom Feed Connector and Heat Exchanger Installation

### BEFORE YOU BEGIN

**Please read the instructions through completely before beginning the rest of the installation. There are four sections left to complete the installation (Bottom Feed Connector and Heat Exchanger, Glycol Fill Valve, Expansion Tank, Pressure Relief Valve). While they are independent of each other you should familiarize yourself with all four before proceeding to make sure the plumbing installation fits all four components cleanly.**

The “Bottom Feed Connector” (BFC) is designed to connect solar water heating system directly to your existing standard water heater. It's main advantages are ease of installation, efficiency, and that under most circumstances it eliminates the need for check valves and the associated increased pumping power requirements.

To install this connector your water heater must be equipped with a standard “boiler drain”. Almost all water heaters have this drain. The only exceptions are extremely small point of use heaters (2.5 gals.) and some side connecting units.

The BFC and boiler drain have standard pipe threads, so during installation apply a generous amount of sealant to the threads before installation. The same is true for the heat exchanger EXCEPT that the two pumps have to be mounted using Teflon Tape on both sides of the pump. It is important to mount the TD5 pump (stainless steel body) in the correct location and to set the power selector properly. If you interchange pumps (mount the HS-21 in place of the TD5) or do not set the power level for the TD5 correctly the system will not work properly.

The heat exchanger mounts directly to the BFC.



## Step 1

Turn off the water heater and locate the “boiler drain”. All standard drains are located near the bottom of the water heater. Drain the water heater using a standard garden hose.

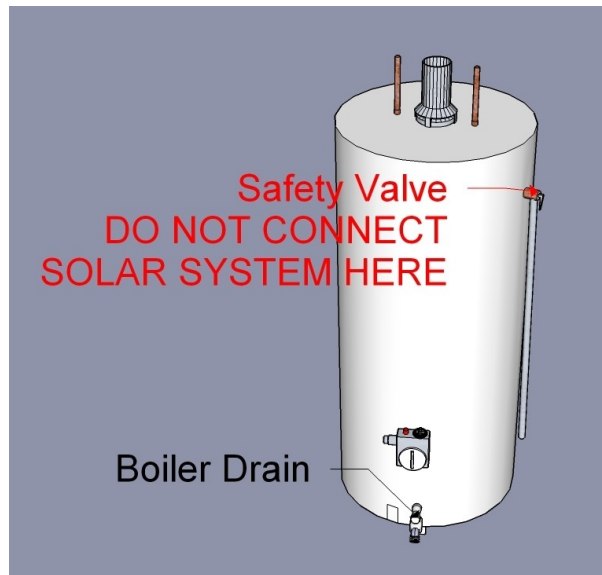

## Step 2

Once the tank is empty unscrew the drain valve to remove it from the water heater tank. The BFC has a built in new metal boiler drain so the existing one will not be needed any more.

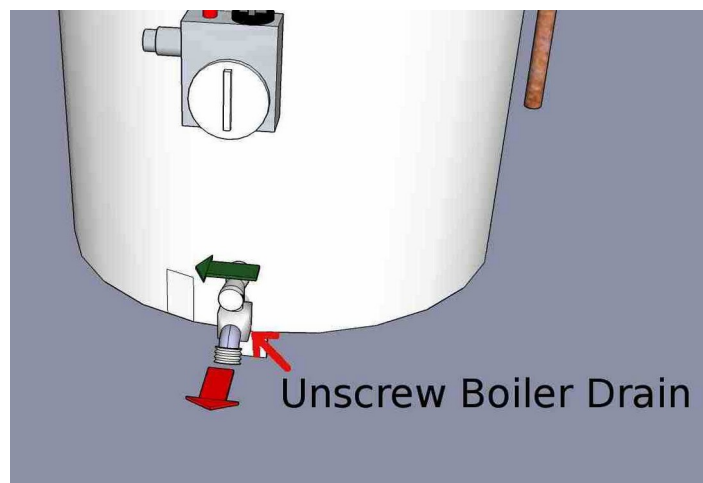

## Step 3

The BFC consists of 2 main parts that are held together by the large nut in the middle. First you have to separate the two parts by unscrewing the big nut. Then thread the steel part (gray metal) into the water heater where the boiler drain used to be using a generous amount of plumbing sealant (included) on the threads.

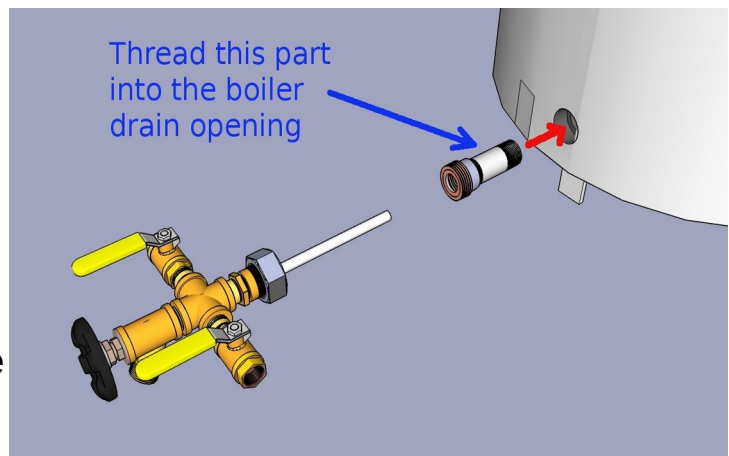

The next steps are most easily accomplished with the brass part of the BFC on a workbench or table.

When installing the fittings and parts onto the heat exchanger the sequence is important. Changing the sequence will cause you to be unable to complete the installation. Also it is important to install the respective fittings on the right ports. If you cross ports the glycol and water loops will not be separate and your domestic water supply will be contaminated with glycol.

## Step 4

In this step the heat exchanger is mounted on the brass portion of the BFC.

Thread the two brass elbows onto the heat exchanger using **plumbing sealant**. If you hold the heat exchanger facing you with the red dot on the bottom right side the elbows go on the two left side ports.

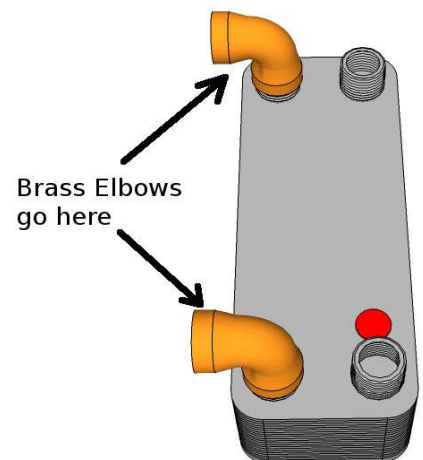

## Freeze Protected System Installation Instructions (2-Row)

Thread a coupling onto the port next to the red dot. Then thread a nipple into the coupling using [plumbing sealant](#) on both.

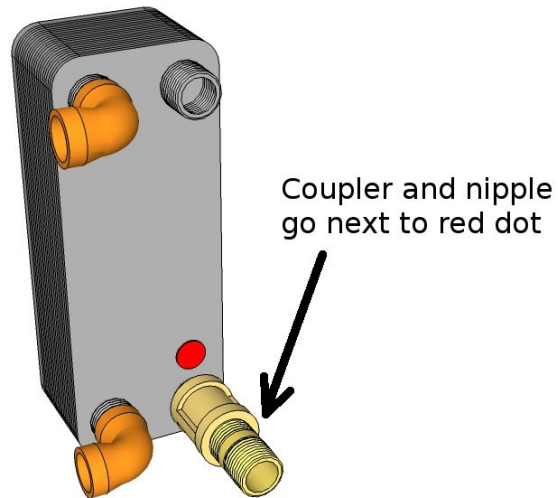

Thread another coupling onto the remaining port on the heat exchanger using [plumbing sealant](#).

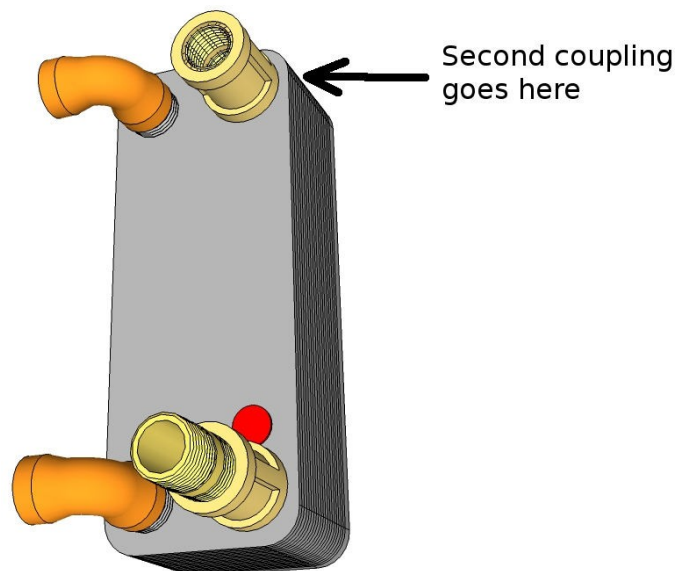

Thread the heat exchanger assembly into the cold (left) side of the BFC using [plumbing sealant](#). The nipple (near the red dot) will thread into the ball valve.

## Freeze Protected System Installation Instructions (2-Row)

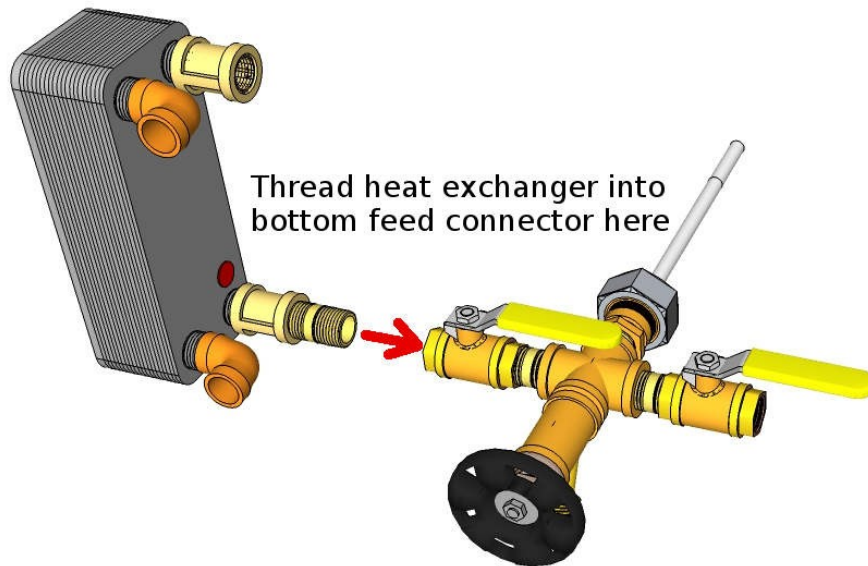

This kit includes 2 pumps. One is a TopsFlo TD5 pumps which has a full stainless body. The second is a Heliatos HS-21 which has an all black Ryton body.

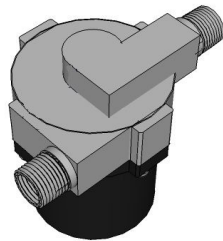

TD5



HS-21

Locate the arrow on the pump body of the TD5. This arrow points to the output and should be pointing AWAY from the heat exchanger. Thread the TD5 into the coupling using a generous amount of Teflon tape.

Next locate the arrow on the HS-21. This should pump INTO the heat exchanger.

Thread the TD5 into the HEX coupling and the HS-21 into the Elbow at the top of the heat exchanger using a generous amount of **Teflon Tape**. The TD5 should pump AWAY from the heat exchanger and the HS-21 pump INTO the heat

exchanger. The arrow on the pump body points towards the output side and should be in the direction of the red arrow in the illustration. **On the HS-21 please use a wrench on the thread you are installing, NOT the one on the opposite side of the pump. The pump cannot withstand tightening torque.**

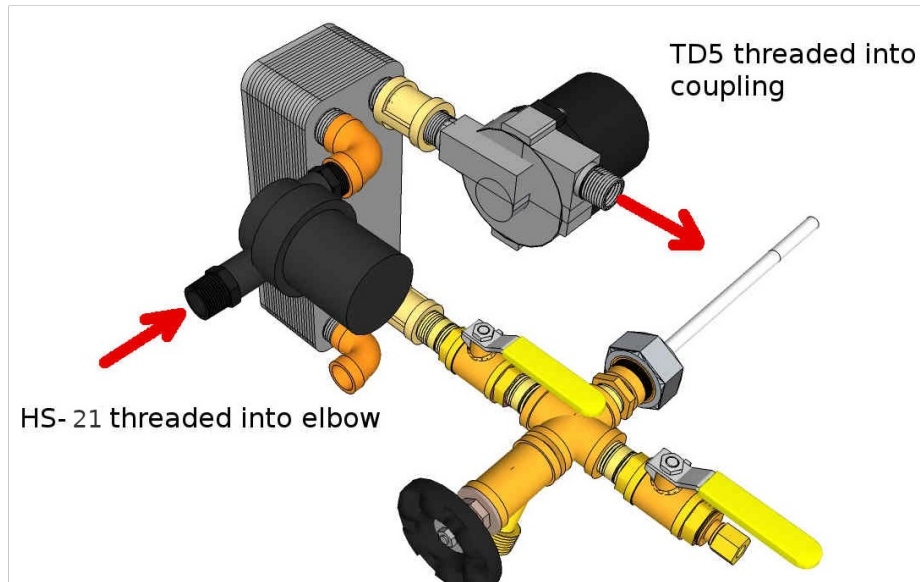

Thread the 3/8"OD Compression to 1/2" Male Pipe Adapter onto the TD5 pump and the 3/8"OD Compression to 1/2" Male Pipe Adapter into the right ball valve on the BFC. Then install the Copper Tube Connector as shown in the diagram.

### **Installation Warning:**

When tightening the 3/8"OD compression to 1/2" male pipe adapter to the ball valve on the hot side of the BFC **DO NOT** allow the ball valve to rotate. It is important to prevent rotation of the ball valve with a wrench while tightening fittings to it.

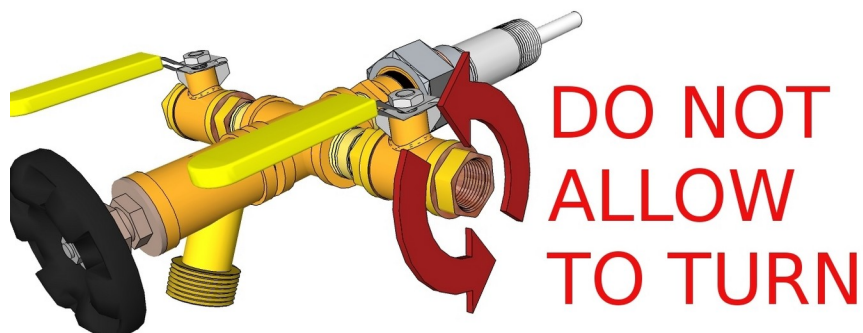

## Freeze Protected System Installation Instructions (2-Row)

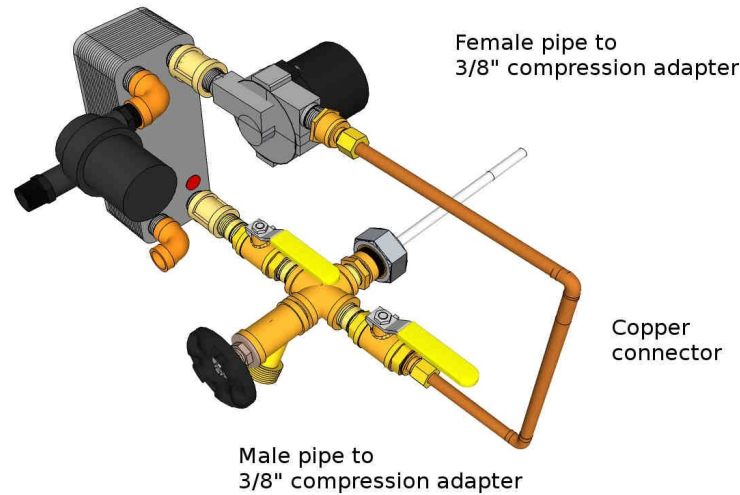

Finally the two push fit adapters can be installed. The push fit to female adapter goes on the second pump and the push fit to male fitting goes in the lower elbow.

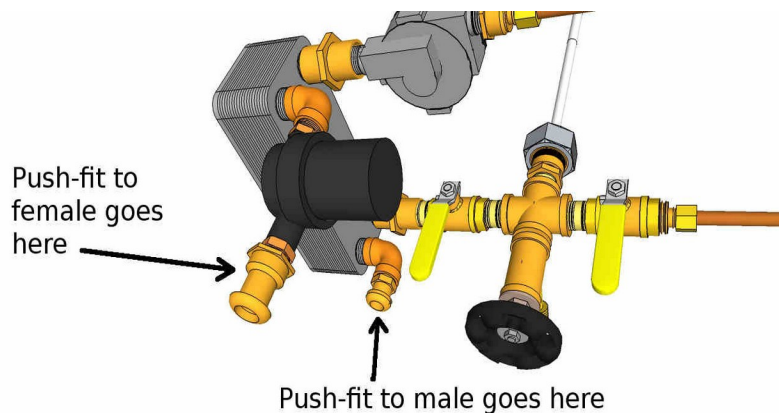

### IMPORTANT

The TD5 pump has a small hole in the back which allows you to select the power setting. A small plastic key is included with the pump to enable you to set the setting.

**It is very important to set this pump so the arrow points between the two number 1's. If this setting is not set correctly the entire system will not function properly.**

The HS-21 does not need to be set up.

## Freeze Protected System Installation Instructions (2-Row)

Now the entire front end of the BFC with attached heat exchanger and pumps can be installed on the tank. Please make sure the rubber gasket inside the large nut is in place correctly.

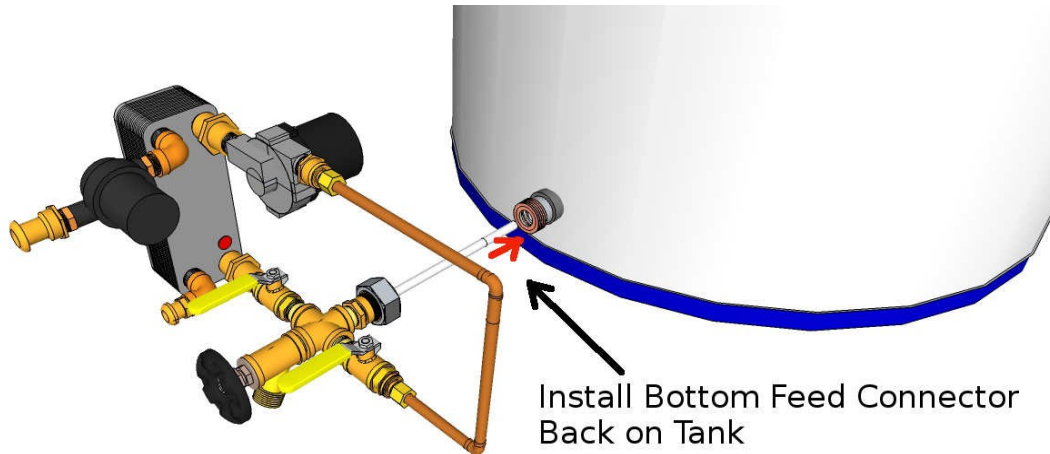

Once the BFC assembly with heat exchanger and pumps is installed on the tank you can start re-filling the tank. As the tank is filling please keep checking the various fittings for leaks.

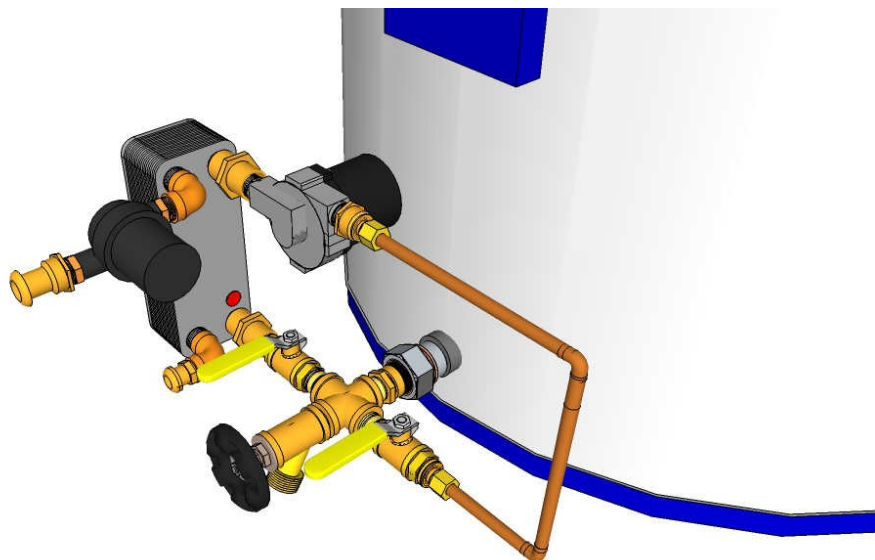

## Step 5

The final step is to insert the pipes going to the panels into the push fit adapters. If you are using piping that is not flexible, especially copper please make sure that the weight of the piping does not rest on the pump. The line going to the array with the cooler glycol connects at the bottom of the heat exchanger using the push fit adapter. The line coming back with the solar heated glycol connects at the top to the push fit fitting on the second pump. The two elbows can be rotated somewhat to make connection easier. You can now open the two valves on the BFC to pressurize the water loop and check for leaks. Open the valve on the left first and then the valve on the right. The water loop simply goes through the TD5 pump and the water connector (copper tube) back to the BFC. Sometimes it can be helpful to slightly loosen the compression fitting near the TD5 pump to let air that may be trapped in the water loop out. You will not have to repeat this after the first time.

### Completed Bottom Feed Connector and Heat Exchanger Installation with Ball Valves in OPEN position

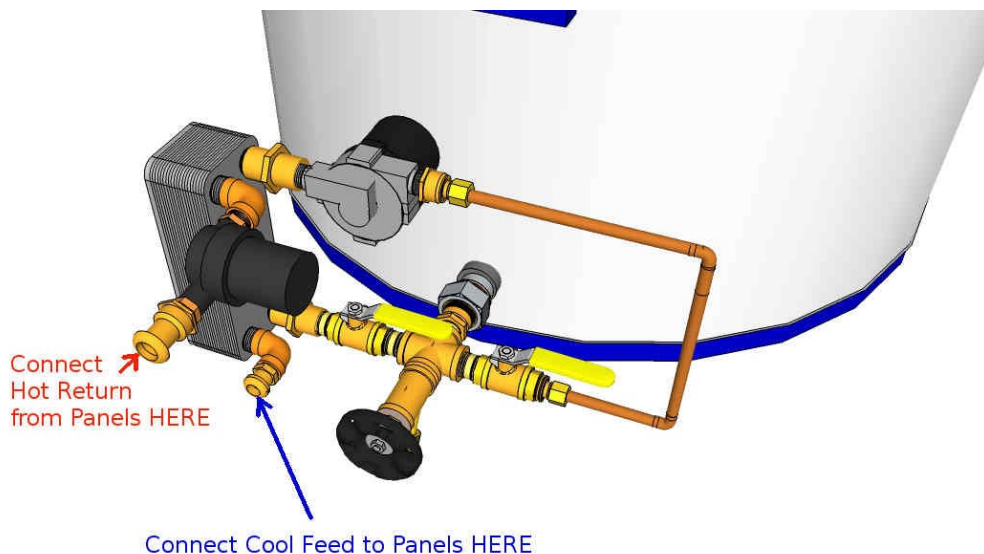



## Installing the PV Panel and Connecting the Pumps

The 25W PV panel has to be mounted next to the water heating panel(s) and is used to power the pumps. This way the pumps will provide flow that is proportional to the amount of sunshine which also supplies the heat into the water heating panels.

Both pumps have to be connected to the same PV panel with the included wire. The PV panel has a small terminal box on the back. After opening it you can connect the included wire, red to the positive terminal and black to the negative side.

The TD5 pump comes with a red (+) and a black (-) wire. The HS-21 pump also has a red (+) and a black (-) wire. Connect the positive wires together using the included wire nuts and then connect the negative ones together.

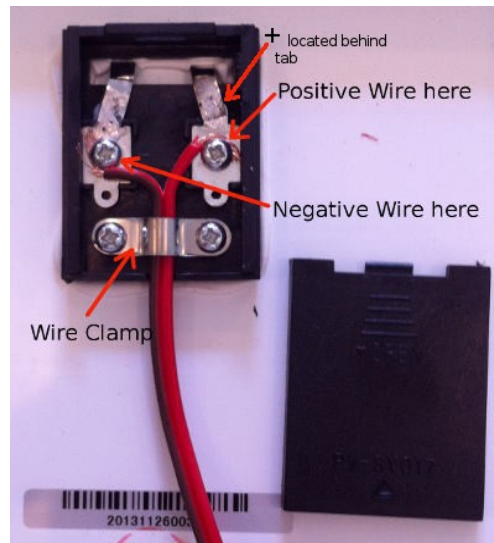

Connect both pumps to the PV panel according to the following table:

POSITIVE Connect together	NEGATIVE Connect together
<p><b>RED</b> from PV panel  <b>RED</b> from TD5 pump  <b>RED</b> from HS-21 pump</p>	<p><b>BLACK</b> from PV panel  <b>BLACK</b> from TD5 pump  <b>BLACK</b> from HS-21 pump</p>

Secure the connections with the included wire nuts.

## Installing the Glycol Fill Valve

The installation of the Glycol Fill valve is described in the instructions that are included in the box with the item itself.

While it can be installed anywhere on the hot return line it is worthwhile to choose the location carefully. Using this valve involves pouring the glycol in a bucket or similar container and extending two two foot hoses (included with the item) into the glycol in the bucket. Therefore it makes sense to locate the fill valve in a place that makes this process easy. Usually this would be on the hot return line close to where it connects back to the heat exchanger so that the bucket can be set on the ground near the water heater.

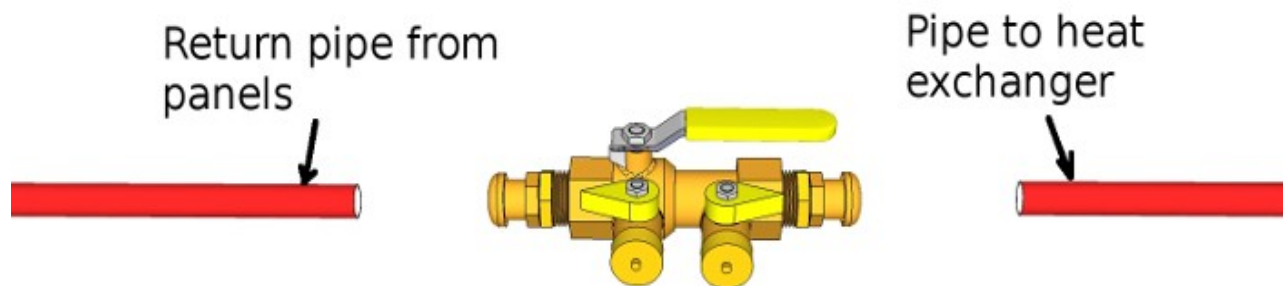

## Diluting the Included Glycol

The level of freeze protection can be selected by the dilution of the included DOWFROST Glycol.

Freeze Protection to	Dilution
-30°F	Mix 1 part DOWFROST with 1 part water
5°F	Mix 1 part DOWFROST with 2 parts water
20°F	Mix 1 part DOWFROST with 4 parts water

## Installing the Expansion Tank

Install the expansion tank inline with the cool feed line going TO the panels. The fittings kit includes an expansion tank fitting. First thread this fitting onto the expansion tank using sealant.

Once the expansion tank fitting has been threaded onto the tank you can install the tank inline on the pipe carrying the cooler glycol from the heat exchanger to the panels. Simply push the pipes into the openings in the push-fit tee until they are seated all the way in. The location along this line is not important.

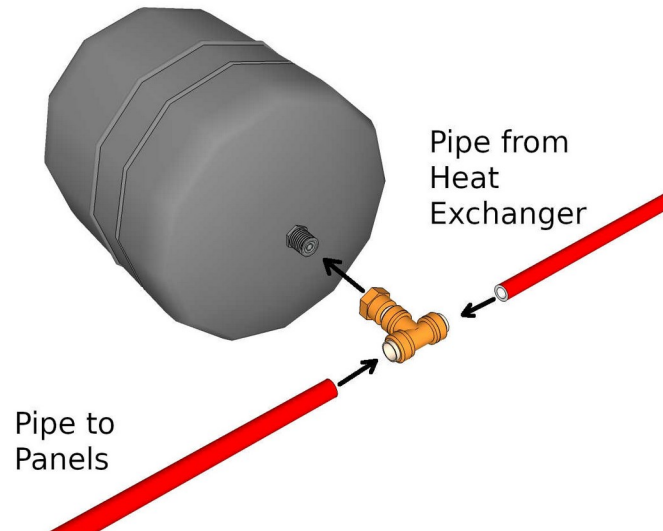

## Installing the Pressure Relief Valve

The pressure relief valve is included in the system to conform to regulations regarding using a single walled heat exchanger. Should some unforeseen event cause a breach between the potable water and glycol side the over-pressure of the potable water side will open this pressure relief valve and cause the glycol to be expelled rather than the glycol entering the potable water.

The Pressure Relief Valve can be installed anywhere in the line carrying cooler glycol to the panels (as with the Expansion Tank), however it should be positioned so that if glycol is expelled from the hole in the red tip it does not cause any damage to the dwelling. So the optimal place would be outside after the pipe exits the building.

To install simply push the pipes into the openings in the push-fit tee until they are seated all the way in.

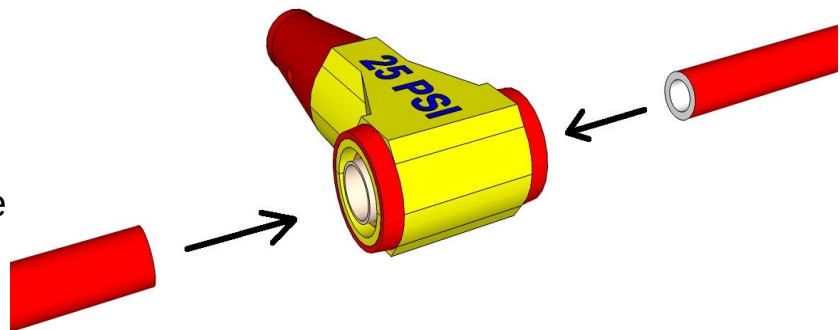



## General Installation Hints

- No matter how warm the climate at your location the insulation of all exposed fittings / pipe is extremely important. Even small exposed areas will cause a lot of the solar heat to be lost. **The system WILL NOT FUNCTION PROPERLY until ALL the insulation is installed.**
- Please observe the polarity of the pumps connecting the positive supply to the red wire and the negative to the black wire. Reversing the polarity will immediately destroy the electronics in the pump.
- It is important to set the power setting on the TD5 pump correctly
- The lower you set the control of any remaining electric heating elements in the water heater the more benefit you derive from the solar heater.
- If the fittings on the panels get very hot but the fittings on the heat exchanger do not it is highly likely that the glycol loop was not filled completely. Please try to flush the glycol loop one more time to remove any remaining air pockets.
- With any persistent problems please call (661)-7SOLAR7 (9am to 5pm pacific time) or email [support@heliatos.com](mailto:support@heliatos.com) for tech-support.