

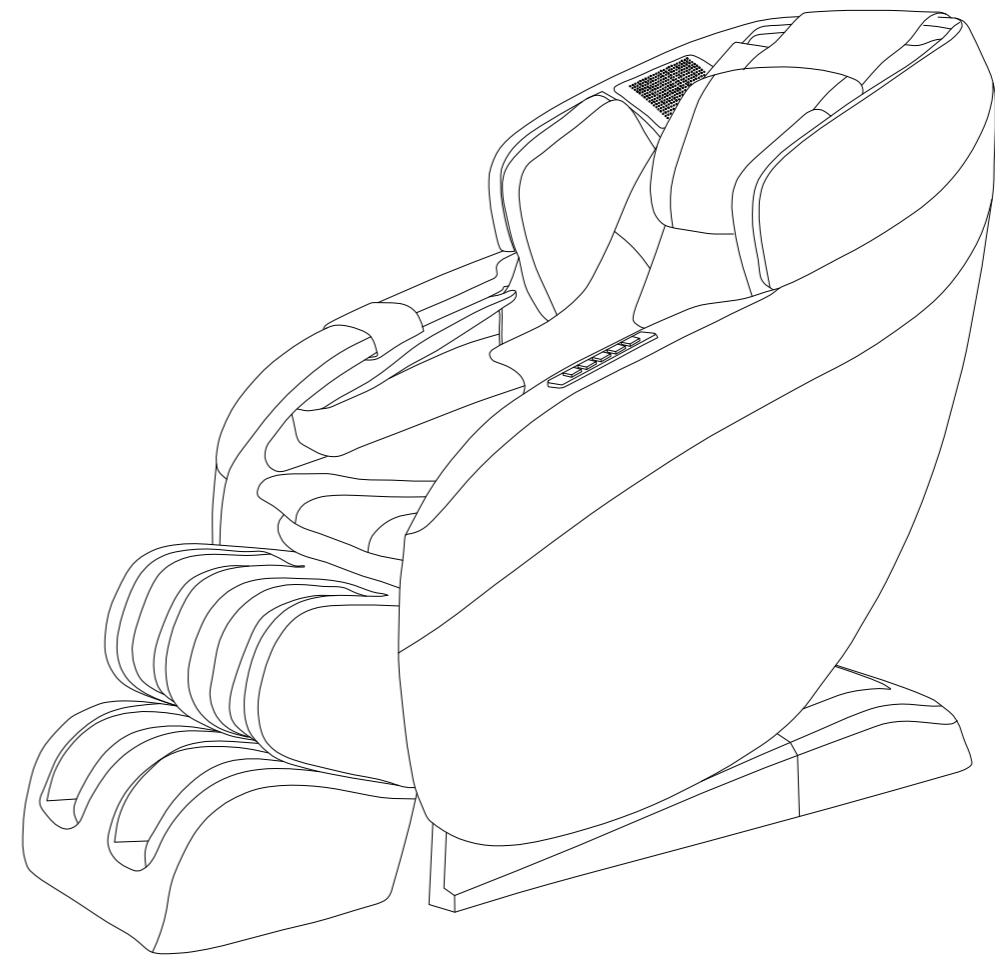

MASSAGE CHAIR

Massage Chair AD-Infinix User 's Manual

*Make your life healthy
and beautiful every day!*



Please read SAFETY INSTRUCTIONS carefully before using the chair.

Massage Chair AD-Infinix Function Introduction

1. The patented backrest is designed to reduce noise as the massage system delivers a life like soothing kneading, rocking, knocking, tapping, shiatsu and rolling massage.
2. The computer body scan automatically scans the body, measuring where the top of the neck is located to ensure a complete and accurate massage.
3. Press the zero gravity button and the chair will recline back, raising the legs and steepening the pitch of the seat base, ultimately putting the user in an optimal stress reduced position.
4. Even in the most limited of spaces, the Infinix massage chair is equipped with space saving technology. When the chair reclines, the base will move forward to reduce the amounts of space required to house the chair. The total space needed from the wall to backrest is 5 inches.
5. Located at the bottom of the seat along the bridge are rollers that spin. The nodes on the rollers will emulate fingers digging into the middle area of the feet, loosening the ligaments and muscles.
6. Calf spinning massager are placed on the mid-section of the legrest. When activated the circular discs will rotate kneading the back of the calves.
7. Airbag massager are located all throughout the massage chair where airbags inflate and decompress on the arms, legs, shoulders and feet. The squeezing action will massage the muscles promoting better blood circulations.
8. The Legrest can be extended and retracted within a range of 8.6 inches, suitable for a variety of different heights. This chair will fit comfortably from 4'10" to 6'3".
9. With a quick control panel on the armrest it easy and fast to start a preset programmed massage.
10. Enjoy the high quality bluetooth speakers by syncing your bluetooth device to the chair. Listen to your favorite tunes while enhancing your massage experience.
11. Located in the lower lumbar area are 2 heating pads that give a warm heat to help loosen the muscle as it gets massaged.
12. This chair is designed for the times were we are so dependent on our devices. The Infinix massage chair has a USB charging port located on the armrest.

- ★ 1.Thank you for choosing ADOR Luxury Massage Chairs
- 2.Please read this manual carefully before using the massage chair.
- 3.Please keep this manual in a safe place for future reference.
- 4.Please pay attention to SAFETY INSTRUCTIONS.

★ Note: We reserve the right for design modification.It is subject to change without notice.The pictures in this manual are only for reference. Please refer to the actual product.

Content

Preparation	Safety instructions -----	1
	External structure parts -----	5
	Internal structure parts -----	6
	Mechanical components diagram -----	7
	Mechanical components list -----	8
Installation	Installation -----	9
Massage Operation	The adjustment before massage -----	15
	Manual control -----	17
	The use method of convenient hand controller -----	21
	Operation instruction &function illustration -----	23
	After massage -----	25
Maintenance	Clean and maintenance -----	26
Others	Malfunction guide -----	27
	Technical data -----	28

Please keep this manual in a safe place for future reference.

- ◆ Please read this manual carefully to make sure the installation and operation of the massage chair is being used correctly.
- ◆ “Safety Instructions” are provided in both Warning and Caution “icons” for important safety information.

The "warning" and "caution" should be fully observed and followed as instructed.

	Warning	This sign indicates warnings of potential death or serious injury.
	Caution	This sign indicates caution of potential bodily injury or damage to the chair

Symbol meaning

	This sign indicates forbidden behavior.		This sign indicates disassembly or tampering is not allowed.
	This sign indicates must follow instruction to operate.		This sign indicates correct operation of cable.

- ◆ The following should be kept for any further references.

Warning	
<ul style="list-style-type: none"> ● People with osteoporosis, vertebral fractures, sprains or muscle strains must consult with your medical doctor before using to avoid serious injury. ● Heart disease patients (including those who have pacemakers or any other medical devices implants must NOT use this product. ● Cancer patients must consult with their with their medical doctor before using. ● People with perceptual disorders or diabetes must consult their medical doctor before using. ● People with abnormal spine or scoliosis must consult their doctor. ● People with bulging discs or any disc issues must consult with their doctor. ● Pregnant women and those who have recently had childbirth must consult with their doctor before using. ● If you have any various skin disease or inflammation must consult their doctor before using. ● Any one that may not be able to discern the surrounding temperature must have supervision. ● If you have fever or any illness you must consult with your doctor before using. ● If elderly in poor health or above 80 years of age must consult with their doctor. ● Anyone with any handicap or mental disability must consult with their doctor before using. A capable adult that can supervise must attend at all times. ● If you are impaired by alcohol or any other substance do not use this device. ● If this chair is wet in any way or you are wet do not use this chair. ● Do not children under the age of 16 use this chair. ● Do not fall asleep in this unit and no external articles such as blankets or pillows are permitted to avoid injury. <p>People with above symptoms should not use massage chair, or use it under doctor's advice. User's discretion is advised when use the chair.</p>	<p>Not suitable users.</p> <p>Risk of causing accident or body discomfort.</p>

Warning	
<ul style="list-style-type: none"> ● Before sitting, please confirm that there are no foreign objects obstructing the function of the chair. ● Before operating the chair be sure to check that there are no people, pets or objects in or around the area (behind, under, sides or in front of the chair). ● In the event if physical pain or irritation is experienced, immediately stop using and consult your doctor. ● If the massage rollers are massaging the head adjust the starting position of the massage to start on the neck area avoiding the head which may lead to injury. ● Avoid excessive neck massage which may cause bruising or soreness. ● Do not massage the abdomen or knees with this machine. ● If you want to leave your seat during the massage, you must stop the massage chair wait for the chair to be in the full upright position before getting out. ● Do not use it with other instruments. ● Do not allow children or pets to play on or around the unit (especially when in use); nor can they sit or stand on backrests ,armrests or legrest. ● Periodically inspect the backrest to ensure the lining is in good condition without any tears. ● Before moving the unit, the backrest and legrest must be in the default fully upright position. 	<p>Accident/injury</p>
<ul style="list-style-type: none"> ● When assembling, make sure there is No power running in chair. ● Insert the plug of the chair into correct power rated power outlet. Make sure the plug is completely inserted into the socket to reduce short circuit or fire risk. ● Unplug the power when not in use, stop all massage functions and turn off the power switch and unplugging the chair from the outlet. 	<p>Fire and electric shock</p>
<ul style="list-style-type: none"> ● Do NOT fold the pads & cushions when placing them in storage. ● Do not let this chair operate for more than a couple of hours consecutively to avoid overheating. Not intended for commercial use. 	<p>Upholstery & Overheating</p>
<ul style="list-style-type: none"> ● If the power cord is damaged in any way do not use the chair and proceed to unplug from the power outlet. ● Don't use other electric power except rated voltage to avoid fire, electric shock or any breakdown. ● Any broken, re-processed, knotted, twisted power cord or pressed under heavy cargo is not permitted to be used. ● Never operate this chair if it has a damaged cord or plug, if it is not working. ● Keep the power line away from stove or other heat sources. 	<p>Fire and electric shock</p>
<ul style="list-style-type: none"> ● If the chair is not working properly or has been in contact with any liquids do not use the chair and contact the manufacturer for technical support ● Self-modification, disassembly or maintenance is forbidden. If power cord or plug is damaged, please don't replace it yourself, please contact us or appointed dealer for replacement. ● To avoid electric shock or bodily harm, please don't open or disassemble any part of the chair. If the chair is found to be opened or tampered by the customer it will void all warranties. 	<p>Daily inspection and maintenance</p>
<ul style="list-style-type: none"> ● Check upholstery periodically on the backrest and other areas to make sure there are no tears or worn out areas before using. if any damage is found unplug the chair and contact your local dealer. 	<p>Daily inspection and maintenance</p>

**Caution**

	<ul style="list-style-type: none"> ● Please operate this chair on a flat and level hard surface. 	To avoid structural failure and injury	
	<ul style="list-style-type: none"> ● The maximum suggested operating time is 20mins. 	When you exceed 20 min per day you may cause injury or bruising	
	<ul style="list-style-type: none"> ● Before sitting on the chair to avoid injury please inspect everything to confirm that the massage heads are in the correct position. 	To avoid accidental injury.	
	<ul style="list-style-type: none"> ● The remote must be place back in the holder. 		
	<ul style="list-style-type: none"> ● Please make sure that the power switch is at the "OFF" position before inserting the power plug into the socket. 	To avoid the accident when turn on the power.	
	<ul style="list-style-type: none"> ● Turn off all controls before removing plug from outlet. 	To reduce short circuits and any fire hazards.	
	<ul style="list-style-type: none"> ● Make sure the plug completely insert into the socket. 	To avoid electric shock in any leakage or breakdown.	
	<ul style="list-style-type: none"> ● Checking whether any damage on wire, make sure no water or dirt is on the power cable. 		
<ul style="list-style-type: none"> ● Make sure the ground plug is in good condition before plugging into the power outlet. 			
	<ul style="list-style-type: none"> ● Don't press with hands or step on the massage heads with feet. ● Don't put hands between the working massage heads. ● Don't put hands or feet in the gap of mechanical parts. ● Don't drop or insert anything into the slot of massage chair. ● Don't stand or sit or put anything on the backrest, armrest or legrest. ● Don't move the chair while in use. ● Don't stand on the chair during operation. ● Don't pull out the plug or turn off the power switch during use. ● Don't put your hands or head between leg-rest or beneath. ● Don't use the massage chair while wearing hair ornaments. 	To avoid accidents or injury	
	<ul style="list-style-type: none"> ● Don't put hard things in pocket when take buttocks and huckle massage. ● Don't sit or press on the backrest when the chair is in reclining position. ● Don't use at bare skin or wore thin clothes, thin clothes may can achieve better massage effect, But it also may cause irritation to the skin or cryogenic burns. 		
	<ul style="list-style-type: none"> ● Do not use massager in close proximity to loose clothing or jewelry. ● Keep long hair away from massager while in use. 		
	<ul style="list-style-type: none"> ● Keep the chair away from heat, wet, sharp things and corrosive, inflammable, explosive environment. ● To use electric blanket or other heating products on the chair is forbidden 		
	<ul style="list-style-type: none"> ● Keep the chair away from stove or other heating products. ● Don't put the chair directly under the sun or other high temperature places. ● Don't put in the space of dust serious or corrosive gas environment, ● Don't put the chair in a small space places or use in the bad air circulation places. 	To avoid fade, discolor on upholstery or hardened, deteriorated on PU.	
			<ul style="list-style-type: none"> ● Don't use the chair outdoor.

Preparation

**Caution**

	<ul style="list-style-type: none"> ● Keep Dry-Don't use or store the chair in the wet environment like nearing the swimming pool, or bathroom. ● Keep the chair and remote control dry all the time. ● Do not use it when user's body is wet. 	To avoid leakage or electric shock.
	<ul style="list-style-type: none"> ● Make sure the ground wire and plug is in good working order. ● Don't use plug adapter (If the enclosed plug doesn't match with socket, please don't change the plug by yourself and find a professional electrician to install a matched socket) 	To avoid electric shock.
	<ul style="list-style-type: none"> ● Unplug the power before cleaning the chair. ● Unplug the power after using the chair. 	To avoid electric shock or fire hazard.
	<ul style="list-style-type: none"> ● Unplug the power when any damage on the power cable. 	
	<ul style="list-style-type: none"> ● When pulling out the power cable from the outlet be sure that the head of the plug is held and not the cable. 	To avoid accidents
	<ul style="list-style-type: none"> ● Please when unplugging the power cable from the outlet be sure the power switch on the base of the chair and remote is in turned off. 	To avoid damage or accidents during power outage
	<ul style="list-style-type: none"> ● Unplug the power immediately when there is a power outage. 	

Preparation

Grounding instruction

The chair provides a power cord that has a ground. Do not use any other power cable unless advised by the manufacturer.

Replace fuse

When the fuse is burned out, please turn off the switch and unplug the power. Opening the lid covering the fuse which is located by the switch box. Using a same size fuse to replace the old one, then cover with the cap. If you do not have a fuse please contact the manufacturer.

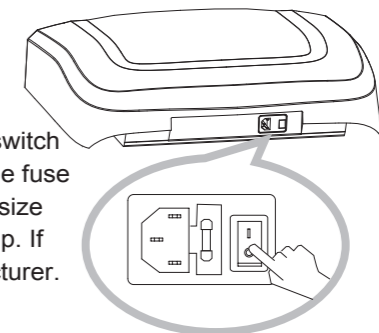

Power cable to kept away from these areas

Keep this chair clear from any gas lines, telephone lines, water lines and electrical cables. If not followed it may lead to explosions, fires and electrical shock, injury or even death.

External structure

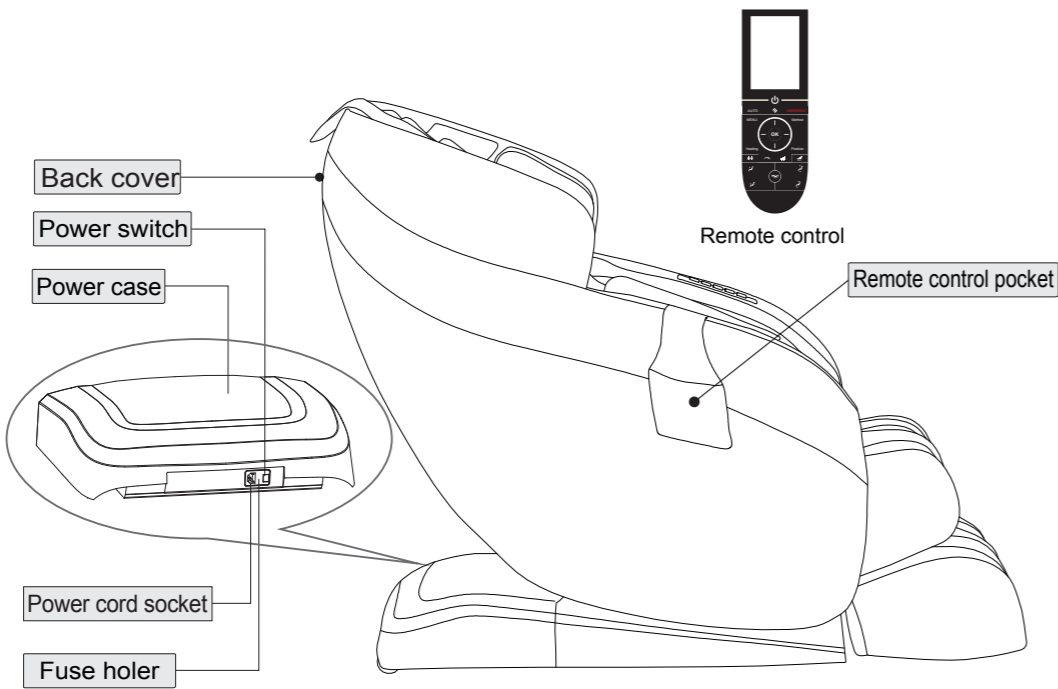
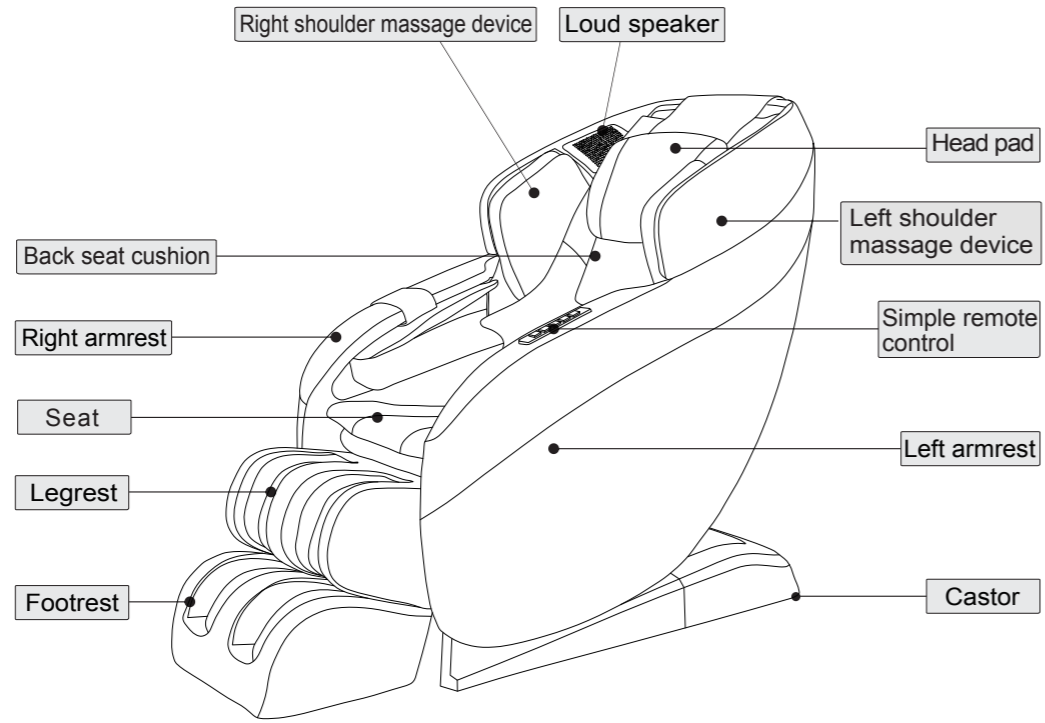

Preparation

Internal structure

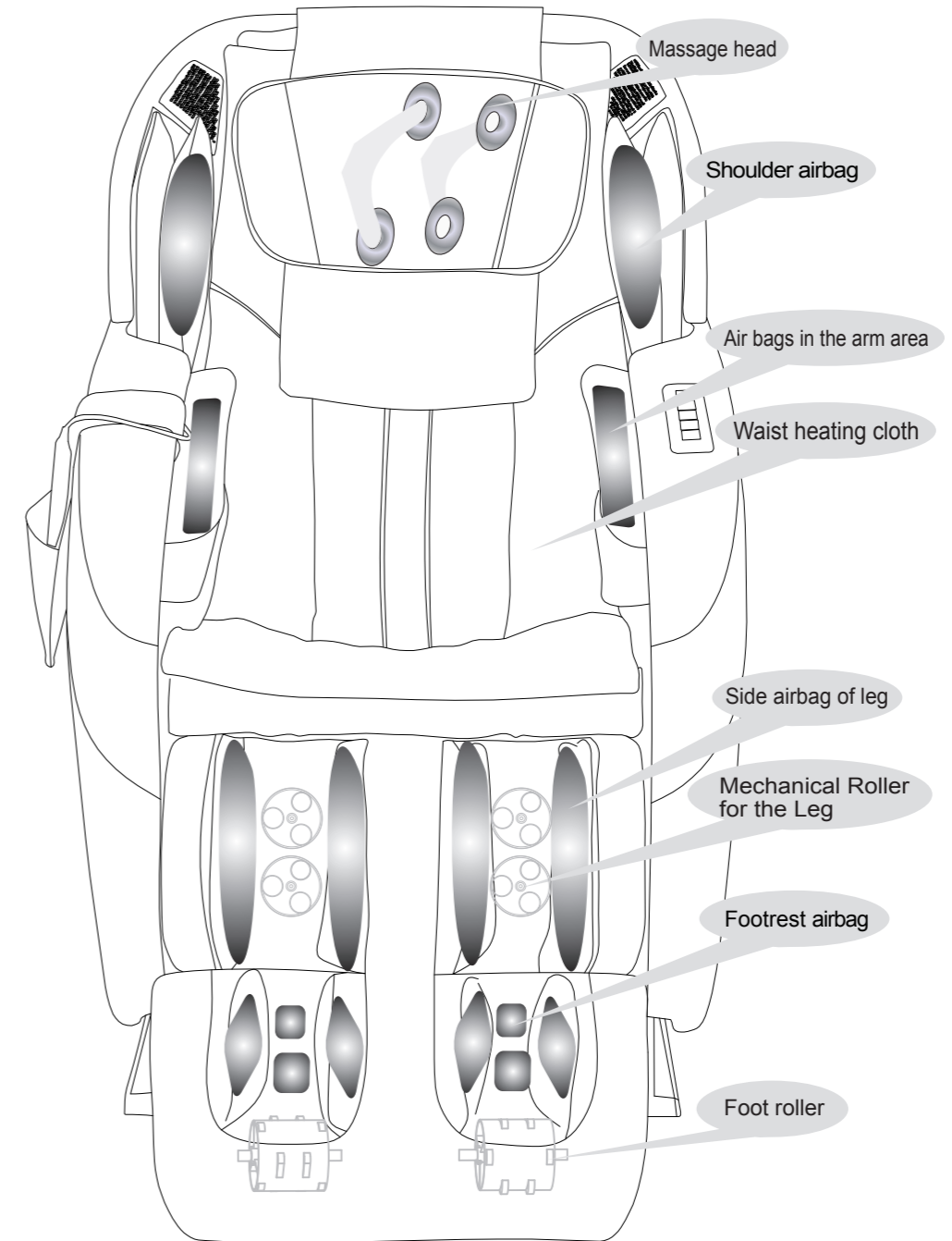

Preparation

Explosion Diagram

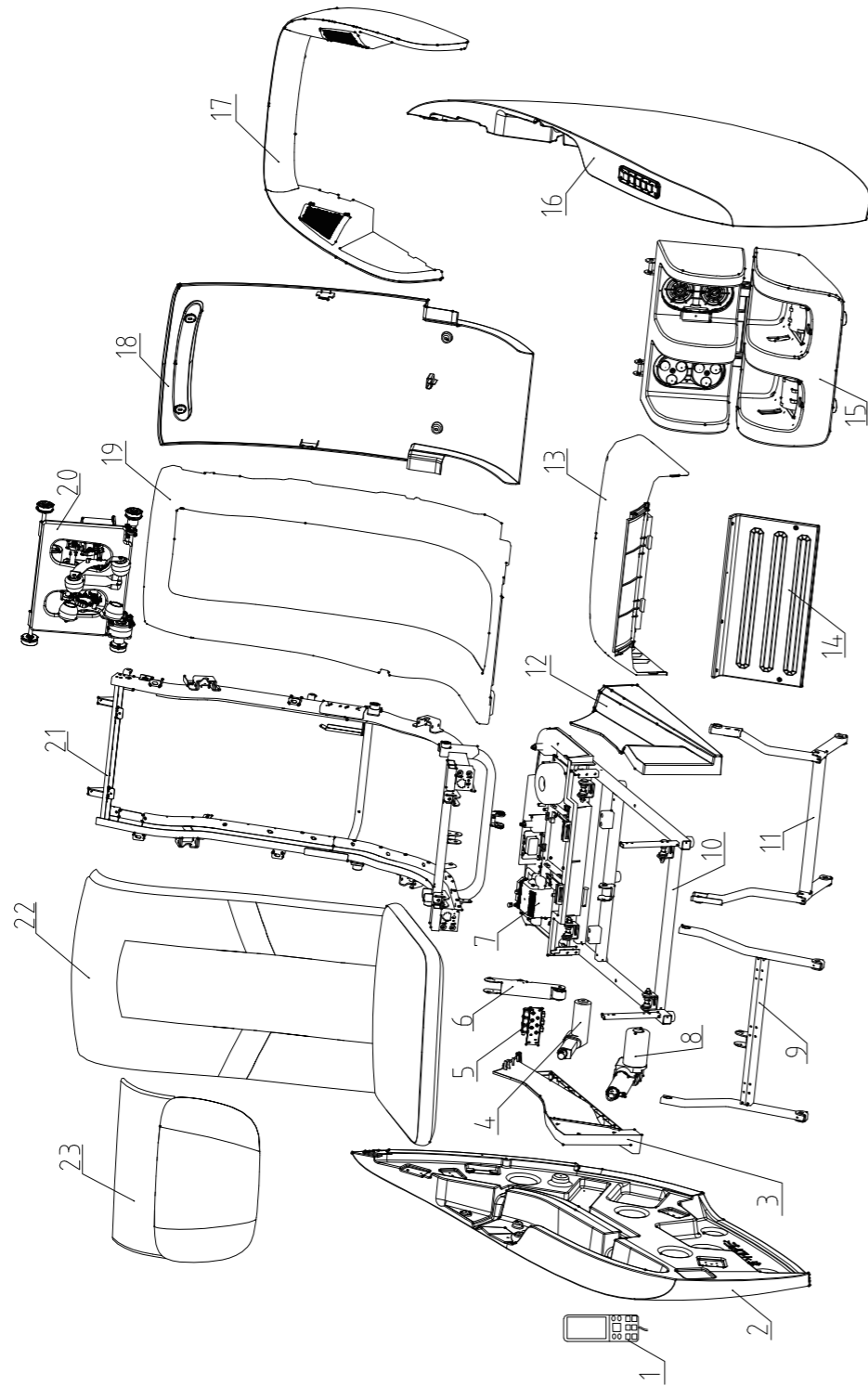

Preparation

Mechanical components list

NO.	Name	Q' ty	NO.	Name	Q' ty
1	Remote control	1	22	Back seat cushion	1
2	Right armrest assembly	1	23	Pillow	1
3	Right side fender	1			
4	Footrest electric actuator	1			
5	Solenoid valve assembly	1			
6	Leg support plate	1			
7	Power case assembly	1			
8	Back electric actuator	1			
9	Front swing assembly	1			
10	Bottom frame assembly	1			
11	Back swing assembly	1			
12	Left Side fender Assembly	1			
13	Power case assembly	1			
14	Front fender assembly	1			
15	Foot and leg assembly	1			
16	Left armrest assembly	1			
17	Shoulder Assembly	1			
18	Back cover assembly	1			
19	Back cover	1			
20	Massage mechanism	1			
21	Back frame assembly	1			

Preparation

Installation (1)

Step 1. Take out the main body and accessories from the carton box.

- ① First take out the accessory box and the legrest.
- ② Use 2 or more people to remove the main body of the massage chair from the box.
- ③ Confirm all the accessories are accounted for.

When removing the legrest from the box be sure to firmly grab it with 2 hands and slide it out of the box and unwrap.

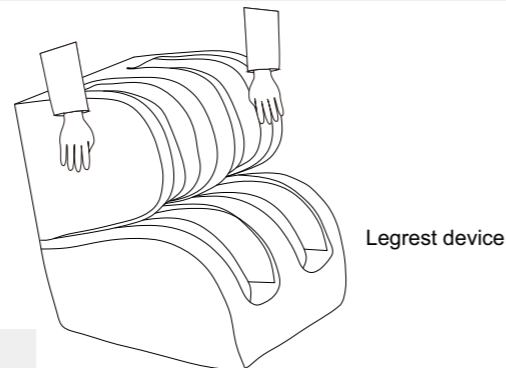

Massage chair main body

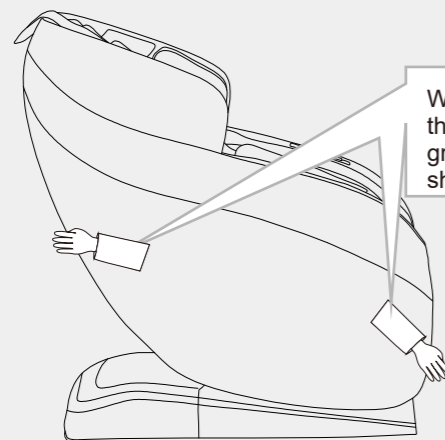

When mounting the side panels grab the areas as shown.

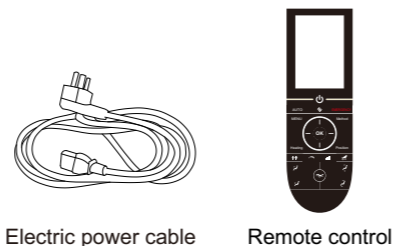
The accessories**Step 2. Placing the Remote in the holder**

located on side panel you will find the remote holder bag stitched by the arm massager. Remove the packaging, flip to the outer wall and insert the remote.

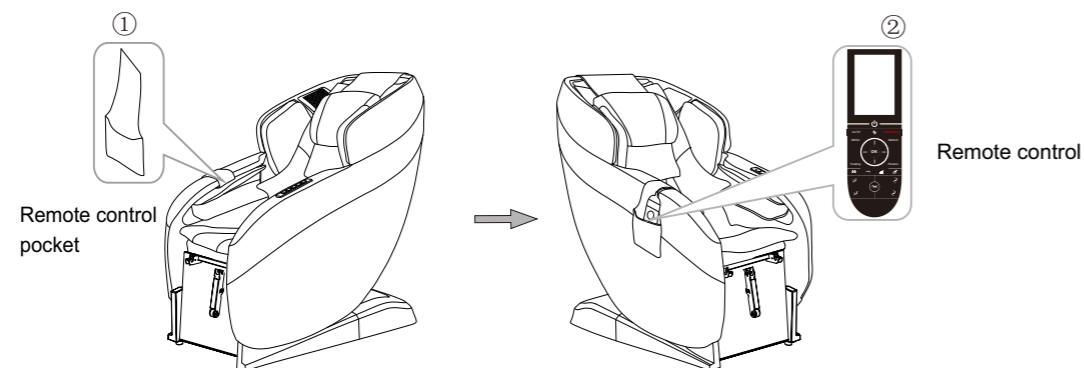

Installation (2)

Check environment

Make sure when placing the chair there is enough space when chair is reclined.

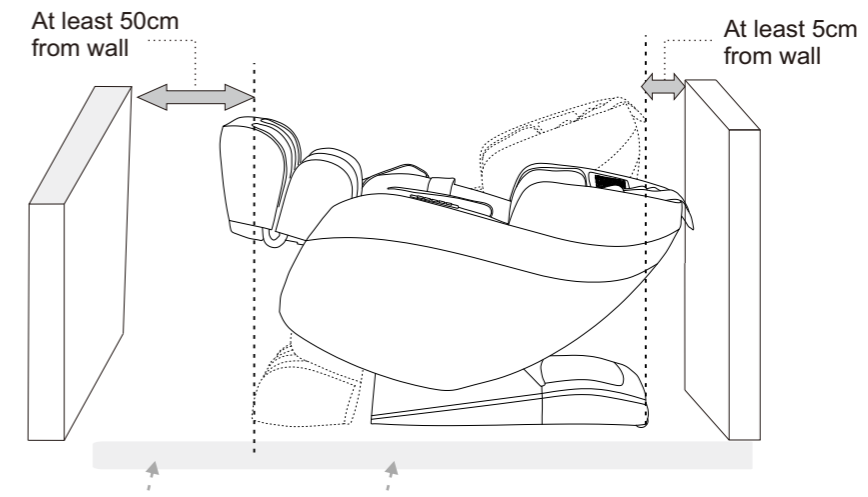

Because the chair is heavy, it may ruin your floor in long time setting. Please put a blanket or other soft things to protect your floor.

- **Caution**
- Don't use the chair near wet or humid places like swimming pool, bathroom, saunas and heating/cooling vents to avoid electric shock and/or injury.
- The chair must be placed flat, leveled surfaces to avoid damage and injury.
- Do not place this chair near a window or any place where it will make contact with sunlight that can cause fading and damage to the upholstery.

Installation (3)

Step 3. Mounting the Leg-rest

Place the legrest in front for front of the base of the chair.

Match the air hose from the legrest to the base. Then proceed to connect the electrical plug into the base.

Raise the legrest with both hands, push the shaft of legrest to the limit level pin hanger. Then thread the bolt to connect the legrest and use the split pin to lock in. Connect the top flap of the legrest to the base of the chair using the velcro stitched on both ends.

⚠ Note: The shaft must be securely attached, otherwise it will fall off. When inserting the air pipe and wiring harness, do not wrap the air pipe and wiring harness together.

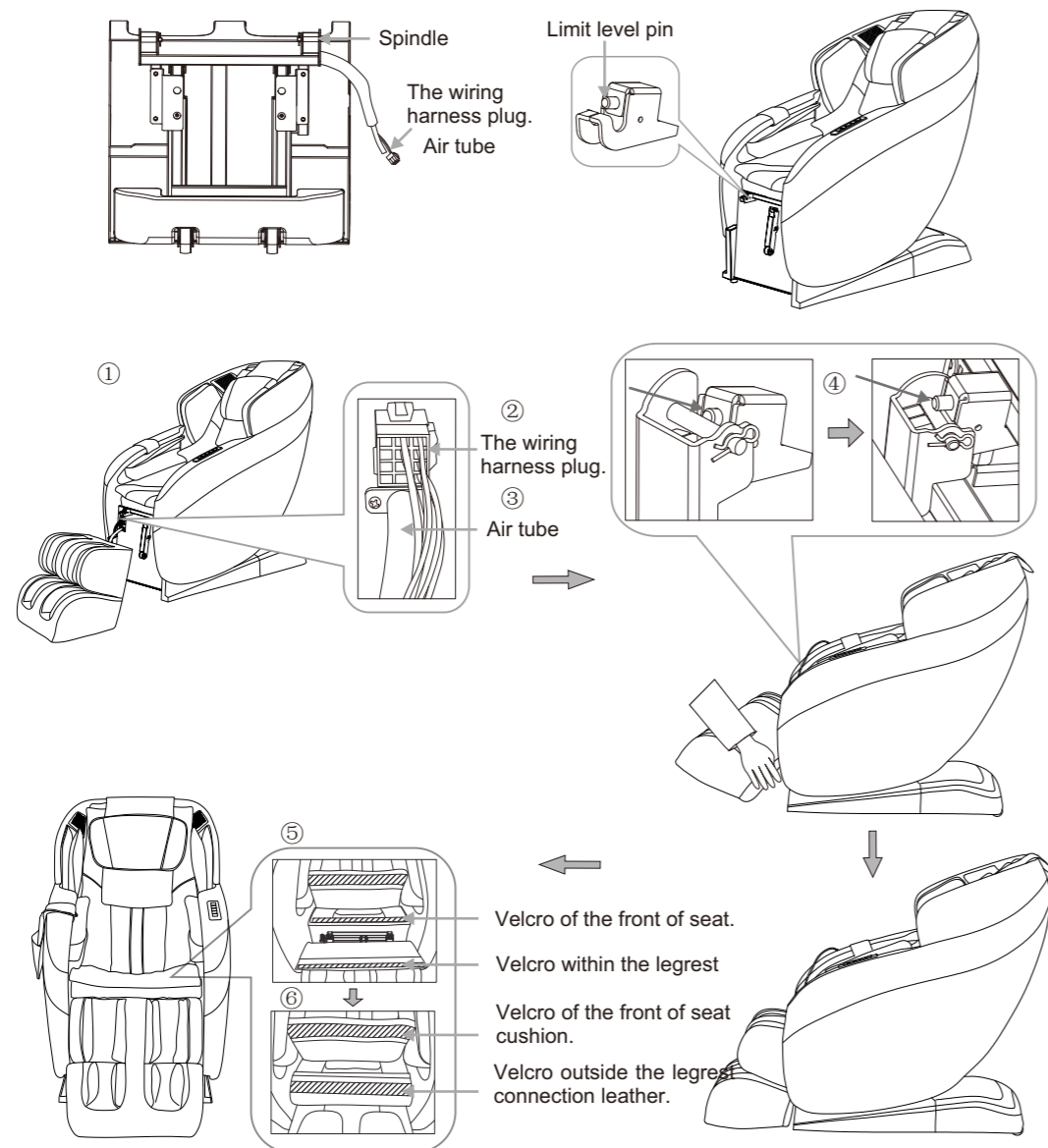

Installation (4)

Step 4. After assembling.

- 1 Plug the cable line in the hole a on the power box as shown in the right picture.
- 2 Insert the plug of cable line into the socket.
- 3 Turn on the switch behind the power box. (Switch on/off "O/I", press I down to turn it on.)
- 4 Press the on button on the remote, select a preset program massage and enjoy!

⚠ Make sure the switch is off before you insert the plug of cable line into the power socket.

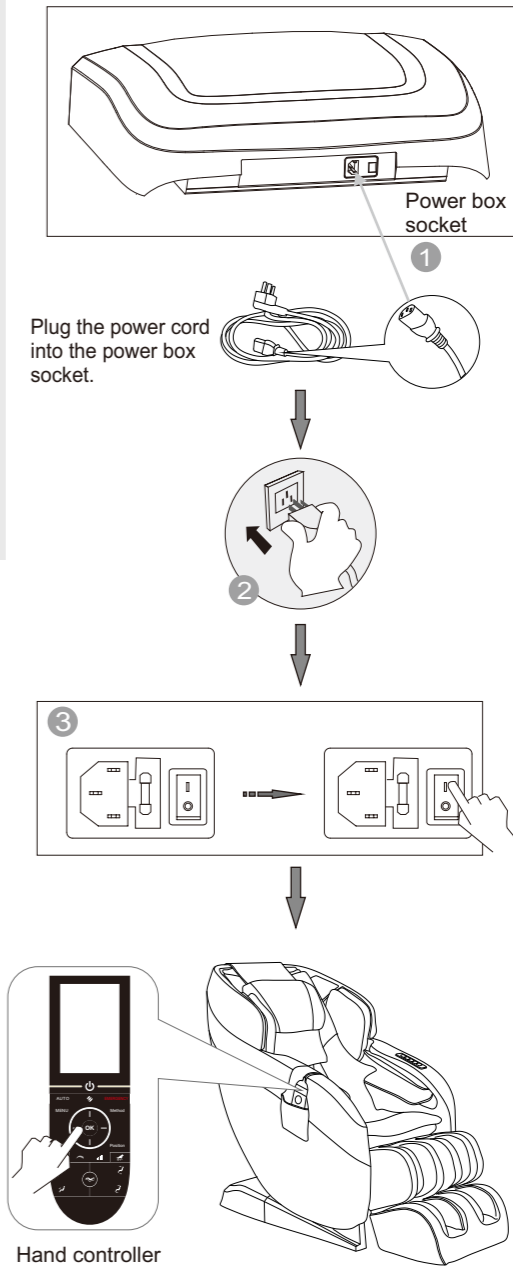

Environment

 Caution

 Don't use the chair in or near wet places like swimming pool, bathroom, etc to avoid serious injury or electric shock.

 Don't use under sunlight or near stove or other heat sources to avoid upholstery deteriorated and fire

 Please use chair on a level surface that is hard and flat to avoid damage and injury.

● Check places in front

Check the surrounding areas to make sure there is nothing around to avoid injury or damage to the chair.

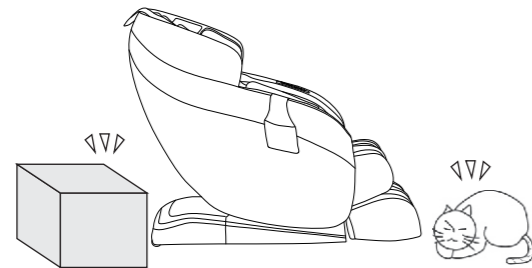

● Check power cable, plug

(1) Using a clean cloth be sure the power cable is clean without damage.

(2) No damage to the cable is a must. If damage to the cable is seen turn off the chair, unplug and contact customer service.

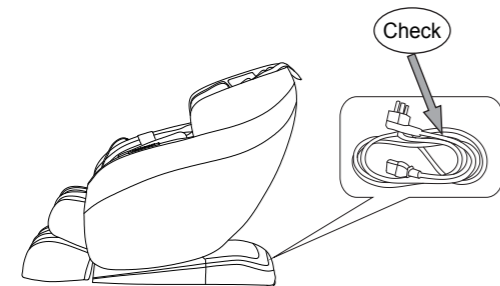

Check environment

● Space to use the chair

- The chair must be at least 3 inches from the wall to recline.

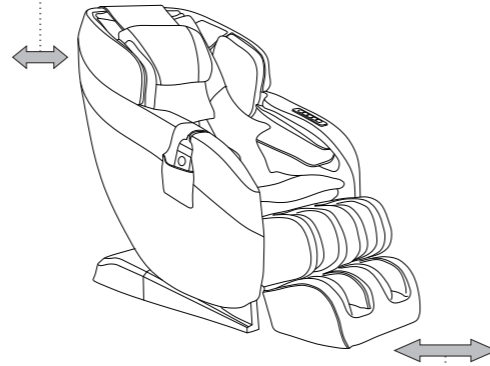

- At least 15 inches are needed in front of the legrest to extend.

● Check surroundings

When the backrest or legrest reclines or extends, please pay attention to:

- (1) Check for any person, pets or things in every direction before using.
- (2) Check there is substantial space to use the chair.

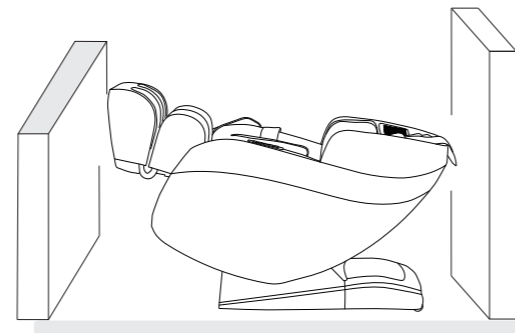
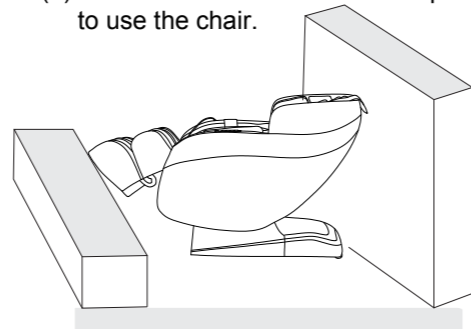

How to move massage chair

 Caution

- ✦ Don't move chair when it's working in case of accidents or damage

How to move

- ✦ Bind the cables and put them in the seat to avoid damage when moving.
- ✦ If you bump or drop the chair, it may damage the inner parts of the chair.
- ✦ Don't use the castor if the floor is wooden or any other soft materials. It will damage your floors. It will need 2 or more persons to lift the chair when moving.

Make sure the power is off and the plug is completely removed from the chair to avoid tripping or damage to the cable.



Normally

- 1 Press down the head part of the backrest to tilt back on the castors. Then push the chair to desired destination steadily and set it down slowly.

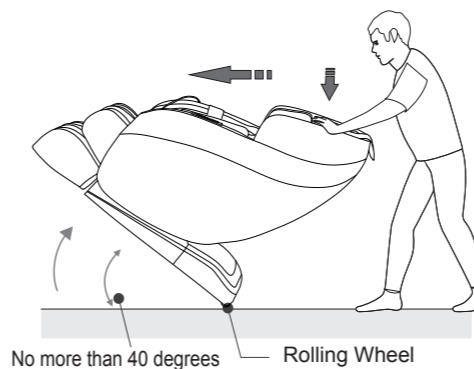

No more than 40 degrees

Rolling Wheel

- ⚠ Be sure the legrest is in the full down position before attempting move. It is even advised to remove the legrest when moving long distances.

Adjustment before massage

● Before adjustment

- ✦ Before starting the massage the rollers should be at the top of the backrest.

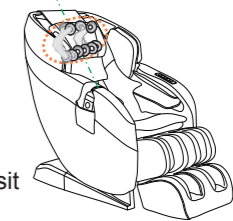

- ✦ When at the top gently sit in the chair to avoid injury.

- ✦ When chair conducts the body scan and is unable to detect where the shoulder and neck is, the massage will start at the highest default position..



Right position:

When getting body scan be sure that your back and shoulders are firmly pressed against the backrest

so that computer can scan your back precisely. Once the scan is complete it will beep. At that time you have to option to adjust the starting point by moving up or down/up button. You have 5 sec to make the adjustment as it beeps to make the adjustment.

● Kind suggestion

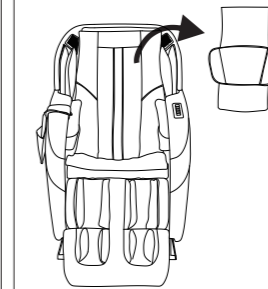

- If you feel the massage isn't strong enough, you can remove the pillow pad on the backrest.

- Because the chair is heavy, it may ruin your floor. Please put a mat or rug under the chair. This will also make the chair quieter during operations.

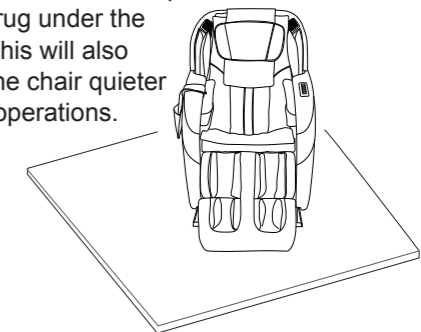

Manual control

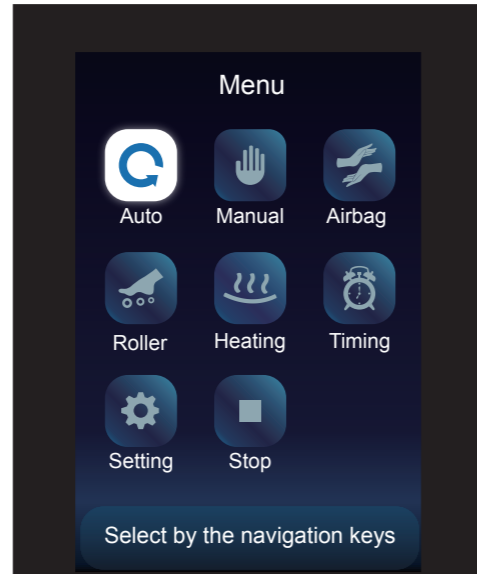

Massage operation



Press this button to power on or off the chair

When pressing this key you can choose from 3 different preset programs. massage programs: " Recover", " Relief", " Stretch". The default working time is 20 minutes.

Pressing this button will activate the air massage intensity from 3 levels.

This button stop the chair immediately.

This will take you to the main menu screen. massage functions of the massage chair. The menu key needs to be used in conjunction with the navigation key, and then press this key to enter the massage status interface.

In the main interface, press this key to switch the massage method. Select from kneading, tapping, knocking, kneading&tap , and shiatsu.

In the power-on state, press this key to turn on and off the waist heating function. When turned on, the corresponding heating symbol turns red, and when turned off, the corresponding heating symbol disappears.

In the state of manual massage, you can press this button to select Whole, Partial and Point .

The navigation direction keys have four buttons: up, down, left, and right. They are used as menu navigation keys in the menu mode. You can use the up and down direction keys to quickly select the menu items, as well as the left and right direction keys to quickly enter the previous and next menus. The up and down direction keys play the role of manually adjusting the position of the massage machine during the shoulder height detection and the fixed-point adjustment function in the manual massage mode.

In the menu mode in the power-on state, press this key to confirm the selection of menu items and pop up the next menu.

During the operation of manual tapping, knocking and shiatsu, press this button on the main interface to adjust the massage width. Narrow , Middle and Wide can be selected.

Under the state of air pressure massage, press this key to adjust the air pressure intensity, 5 levels can be adjusted.

Under the manual massage state, press this key to adjust the massage speed, 5 levels can be adjusted.

Under the state of power on, press this key, the sole roller can select three speed of Quick, Soft and Stop in sequence.

Press and hold this button, the leg will rise, release this button, the leg will stop running.

Press and hold this button, the leg will descend, release this button, the leg will stop running.

Press and hold this button, the backrest goes up and the legrest goes down. Release this button and the backrest and legrest stop running.

Press and hold this button, the backrest goes down and the legrest goes up. Release this button and the backrest and legrest stop running.

In the power-on state, press this button to adjust the chair posture to zero gravity , then press this button again to reset the chair to the initial working state. The zero gravity icon on the main interface will show the current zero gravity status after the massage starts.

Massage operation

LCD display graphic description

Menu Main Interface

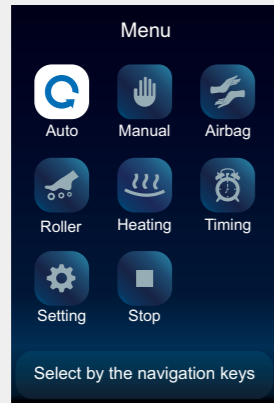

After power on ,if you press the “on/off ”button,the buzzer will ring with a short and crisp sound.The LCD displays the main menu interface and enters the standby state.The Main screen displays information such as auto,manual ,airbag,roller, heating, timing,setting ,stop current working state,etc.Those information will be updated in real time after the operation.

Under the main interface of the menu displayed on the LCD screen,press the “Menu”button to enter the massage state interface,and then press the “Menu”button to return to the main interface of the menu.

Massage State Interface

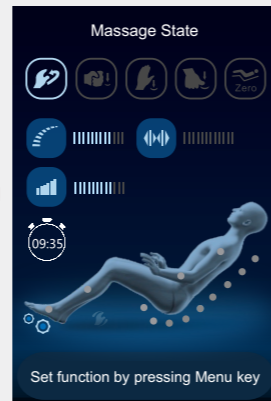

Massage function
 Kneading Tapping Knocking
 Shiatsu Zero gravity Massage time left

Air Massage Strength(5 levels)
 Massage speed (5 levels)
 Massage width(narrow, mid, wide)

Massage position

After pressing the “OK”Key in the main menu interface,it will switch to the menu interface and all massage functions can be set by pressing the button.Pressing the “Menu”key in the menu interface will exit the menu and return to the main interface.

Auto Massage: After pressing the “on/off”key, the cursor will stop in the automatic massage program by default. After pressing the “OK” key, you will enter the menu interface. There are the following massage modes: “Recover”, “Relief”, “Stretch”, “Music Sync”, “Renew”, “Calming”and “Special”. Under Special, there are two automatic massage modes to choose after pressing “OK”.

Manual Massage: On the main interface of the menu, select manual massage through the navigation key. After pressing the "OK" key, there are four functional options: mode, position, width and speed; After selecting the corresponding function, press "OK" to enter the next menu, and select the desired massage mode: kneading, tapping, knocking, kneading and tapping, shiatsu; Massage position include whole, partial and point; Massage width and speed.

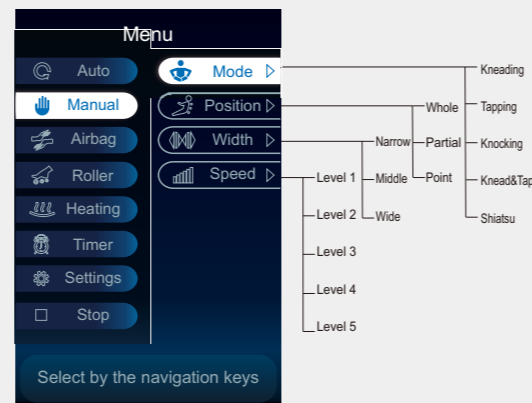

Massage operation

LCD display graphic description

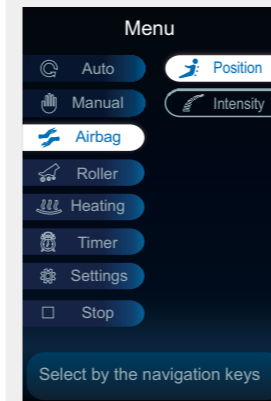

Airbag: In the main menu interface, use the navigation keys to select "Airbag", after pressing the [OK] key, there are two air pressure function options: position and intensity. After selecting the corresponding function, press the [OK] key to enter the next menu and select the desired massage parts: full body, upper body, legs and feet; message intensity: 5 levels of display.

Foot Roller: In the main interface of the menu, use the navigation keys to select Roller. After pressing the [OK] key, you can choose quick, soft and stop.

Heating: In the main interface of the menu, use the navigation keys to select Heating. After pressing the [OK] key, you can choose to turn on or turn off waist heating.

Timer: In the main interface of the menu, use the navigation keys to select Timer. After pressing the [OK] key, you can choose massage time to 10 mins, 20mins or 30 mins. The default time is 20 mins, the massage chair will turn off automatically when the time is up.

Settings: In the main interface of the menu, use the navigation keys to select Settings. After pressing the [OK] key, you can choose the desired language.

Stop: In the main interface of the menu, use the navigation keys to select Stop. After pressing the [OK] key, the massage chair stop massaging, and heating turn off. Press Menu key again, to go back to main interface.

When power on, the first time you use the auto program, massage chair will start the body scan and “body scanning...” will be shown on screen. After the body scan is finished, the buzzer will tick (once every second). At this point, the massage rollers are in the shoulder position, you can press Up and Down to adjust. When adjusting, “shoulder height adjusting...” will be displayed on the screen. The default working time is 20 minutes. The massage chair will turn off and reset to its upright position once the massage is over.

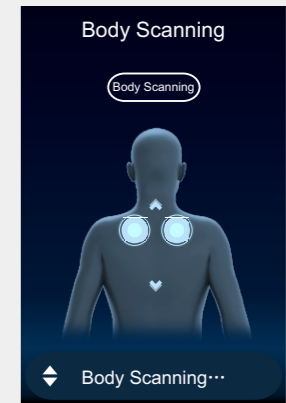
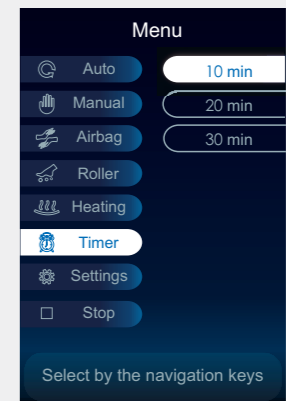
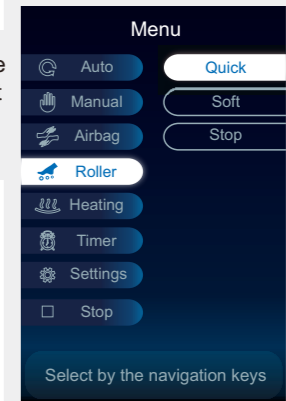

Massage operation

How to Use the Simple Control

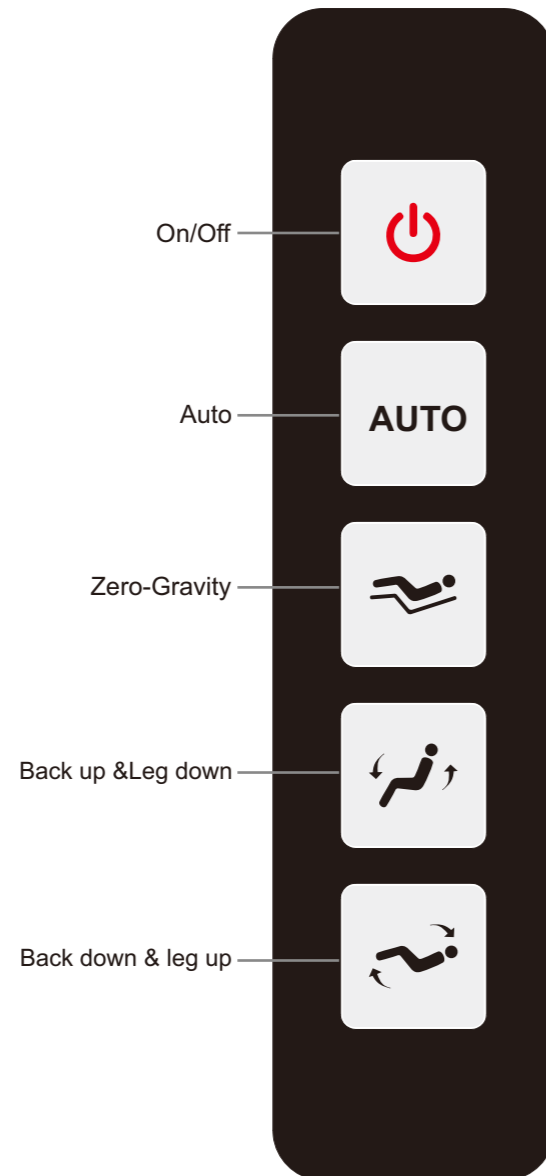

1. Press on/off key to turn on or turn off the chair.



2. In on status, press the Auto to enter three auto programs: Recover, Relief, Stretch.



3. In on status, press this button, massage chair will go to Zero-gravity position, press it again to return to the original position.



4. Keep pressing this button for seconds, backrest goes up and legrest goes down. Release this button, backrest and legrest stops moving, the angle is locked in this position.



5. Keep pressing this button for seconds, backrest goes down and legrest goes up. Release this button, backrest and legrest stops moving, the angle is locked in this position.

ON/OFF

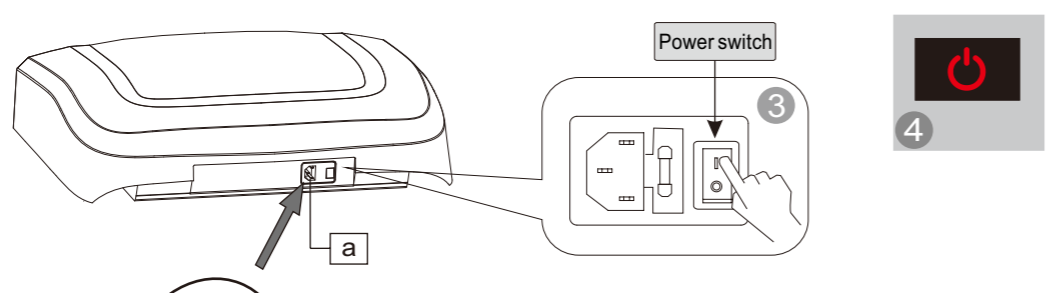

Step1. Power on

- Put one end plug of power line to "a" hole.
- Put power plug to socket.
- Turn on the power switch on the power box, massage chair powers on.
- Press "ON/OFF" button on the remote which will beep once. It will then enter the display interface .

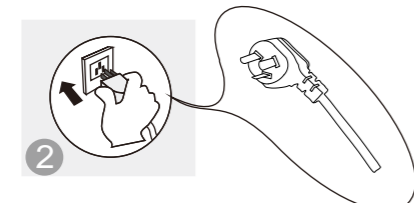

Step2. Massage

- Operate according to controller operation instructions. As for the massage method's details, please refer to remote control's Usage page.
- When the massage ends, massage machine will return to the default position, meanwhile "Shutting down" will be displayed on the controller.



Remote control

Step3. Turn off the power

- When the chair is On, press On/Off button to turn off the massage chair and it will restore automatically.
- Turn off the power switch on the bottom of the back of chair after the rollers reach storage position.
- Unplug the power plug from the socket.



Warning

- Before using, pull up the pillow, back cushion etc. to check if the PU material is broken, if there is damage, please stop using, unplug the chair, and ask for repairment.
- Only plug to proper socket.



Attention

- Before sitting down, make sure there is no things pinched between armrest, legrest , backrest and seat of the chair.
- Make sure the chair is in reset state before using.
- Do not stand on it when using the massage chair.

Function Illustration

● Legrest Up

Press this button on controller, legrest goes up. Release the button, legrest stops moving, the angle is locked in this position.

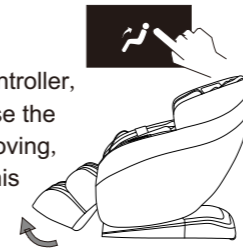

● Legrest extend and retract

Legrest can extend or retract within a range of 22 CM.

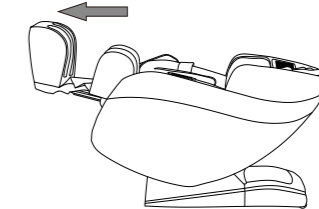

● Legrest Down

Press this button on controller, legrest goes down. Release the button, legrest stops moving, the angle is locked in this position.



● Backrest Down/Legrest Up

Press this button on controller, backrest goes down and legrest goes up. Release this button, backrest and legrest stops moving, the angle is locked in this position.

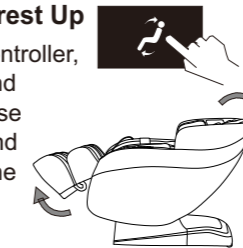

● Backrest up/Legrest down

Press this button on controller, backrest goes up and legrest goes down. Release this button, backrest and legrest stops moving, the angle is locked in this position.

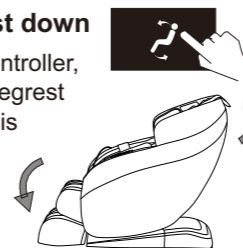

● Zero gravity

Press the button "Zero", backrest go down and legrest raise up, the chair go into Zero gravity status automatically. Press the Button again, the backrest and legrest stop moving, and it will lock at this position. However to change the angles, we can keep comfortable massage status all the time.



● Arm massage

The armrest has built-in pulse pressure massage function, put your arm in the air bag when it is not inflating. After the airbag is inflated, the arm and palm can be massaged, no matter how the seat changes, can always maintain a comfortable massage state on the arm.

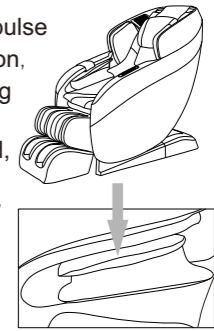

● Shoulder massage

Multilayer extrusion airbags is deployed on both sides of the shoulder. Achieve pressure shoulder stretch massage, relieve shoulder fatigue.

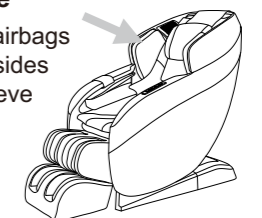

● Foot massage function

Foot massage function : The foot has an all-around rolling and airbag massage function. By stimulating the foot reflection area, it can dredge the meridians of human body, regulate and restore the body's viscera function, effectively improve human body resistance and immunity.

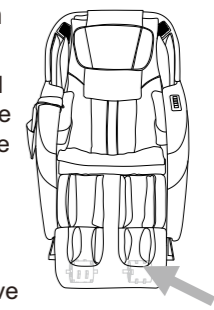

- Please make sure there is no people, no pets or any stuff around the backrest to avoid unexpected hurt or property loss.
- When adjusting the backrest, be careful of the gap between the backrest and armrest.
- When the legrest is moving, please do not stand on or leave from the seat, do not stop the legrest from moving in case of causing damage to the chair.
- Please refer to control instruction for more details.

Restoration of massage chair

- 1 Make sure there is no people or pet or anything within the range of backrest and legrest.

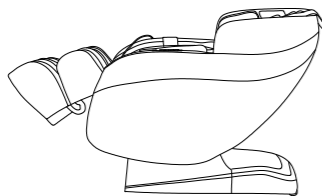

- 2 Make backrest and legrest restore to the normal position by controller.(or press ON/Off key to make backrest and legrest restore to the normal position)

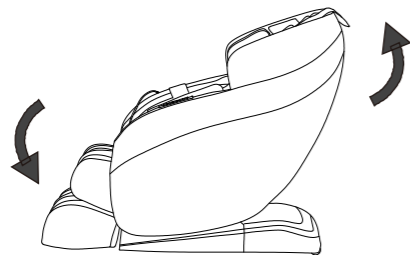
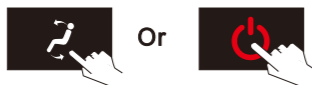

- 3 Put the controller back into the controller bag of the right armrest after the chair back to the initial position.

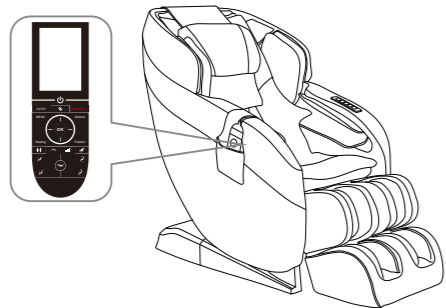

- 4 Switch off the power.

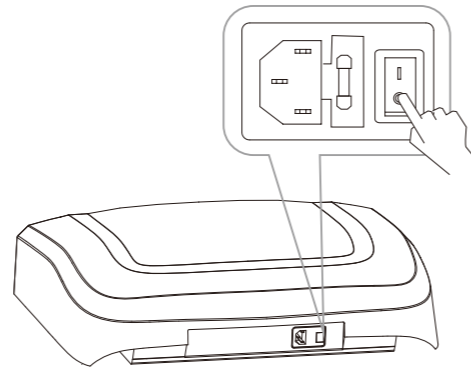

- 5 Unplug the electricity from the socket. (Attention: hold the right plug position)

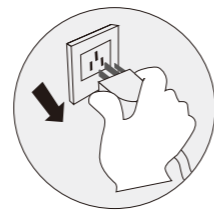

- 6 Clean the chair if necessary.

! Attention!

- After using, press ON/OFF to end all the massage method and wait for restoration. Make sure to cut the electricity to avoid any unexpected hurt to children or pets.
- After using, turn off the power, unplug the electricity. Avoid moisture, dirt and aging of insulation in case of causing damage.

Synthetic leather

● **General cleaning**

Clean with tidy, soft and dry cloth slightly.



Do not use the thinner, gasoline, alcohol or other chemical materials.

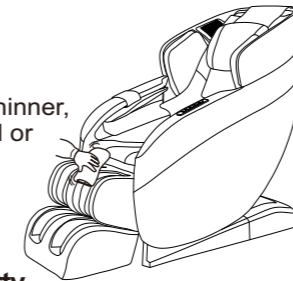

● **If leather is dirty**

- 1 Dip soft cloth into 3-5% neutral detergent solution, squeeze it then clean the stain on the surface gently.
- 2 Wash cloth, squeeze it and wipe with detergent.

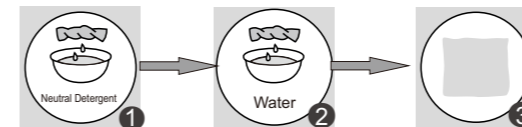

- 3 Clean it softly with dry cloth.
- 4 Allow to dry (air blower is prohibited)

Cloth material

- 1 Dip cloth into weak neutral detergent, squeeze it and clean the material surface.

- Do not use the thinner, gasoline, alcohol or other chemical materials.

- 2 Brush the dirty parts with weak neutral detergent. (avoid excessive brushing)

Excessive cleaning may cause damage to cloth material.

- 3 Wipe with water-dipped but squeezed cloth.

- 4 Allow to dry.



Plastic parts

- 1 Dip cloth into neutral detergent, squeeze it and clean.
- 2 Wipe with water-dipped but squeezed cloth.
- 3 Allow to dry.

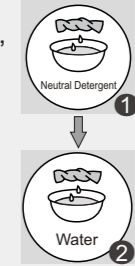

Clean the controller

- 1 Wipe with soft cloth after squeezing.
- 2 Allow to dry.



Do not use the thinner, gasoline, alcohol or other chemical materials.



Remote control



About cleaning

- Before cleaning, unplug the electricity, don't touch plug with wet hands.
- Make sure hands are dry when plugging to the socket.
- If failed to follow the mentioned instruction, user may get electric shock or burned.

FAQ and Troubleshooting

Trouble	Possible reason	Troubleshooting
The massage chair can't work after power is on.	Check if the control is on or not.	Open control switch
	Not choose massage function	Choose massage function
	Check whether the plug and socket in poor contact.	Make sure plug and socket are connected.
	Wire or plug has damaged.	Please ask manufacturer or appointed or authorized maintenance man for checking and replacement.
	The fuse burned out.	Replace fuse of same specification.
	Something wrong with inner circuit	Please ask appointed or authorized maintenance man for checking and repairing.
There is beep sound inside the massager while working.	It is sound of air pump, motor and mechanical parts.	Normal sound, no need to pay attention to it.
Different height of the left roller and right roller.	Massage rollers work on shifts.	Normal, no need to pay attention to it.
Sound suddenly becomes much louder while working.	Check if it is due to long time working.	Turn off the power to have the massager rest for over half an hour before next turn working.
	Inner parts fretted away due to long time work. It's normal	Please ask appointed or authorized maintenance man for checking and repairing.
Massage function suddenly stops while working.	Suddenly power-down	Connect the electricity power again
	Setting time is up.	Turn off the power to have the massager rest for over half an hour before next turn working.
Neither the backrest nor the legrest can be lay down.	Check if there are any obstacles; the chair overloads; for the sake of safety, sometimes the massage machine may automatically stop working.	Remove the obstacles; turn off the power to have the massager rest for over half an hour before next turn working.
The chair can't return to its original position.	Excessive operation; setting time is up.	Please ask manufacturer or appointed or authorized maintenance man for checking and replacement.
Electric wire or plug give out heat	It may work overload	Turn off the power to have the massager rest for over half an hour before next round working.
	Other abnormal case	Stop using, and ask appointed maintenance man for help.



Note: If the troubles are not caused by above reasons, please turn off the power switch and cut off the power, then contact the manufacturer or service agent to repair your chair.

Technical data

Name	Massage Chair	Power	180W
Model	AD-Infinix	NW/GW	84/100.5kg
Input voltage	120V~ 60Hz	Packing size	1160×770×1265mm (L×W×H)
Safety design	Class I		