



Available Lights



DURA 4 LED
DURA-410



FORD F250/F350 FOG LIGHT KIT







Installation Instructions & User's Manual



VISION X



KIT INCLUDES

1 Superduty Bracket 	2 Bolt (6mm) 	3 Washer (6mm) 
MOUNTING Qty: 2	Part (M1) Qty: 6	Part (M2) Qty: 12
4 Nylock Nut 		
Part (M3) Qty: 6		
5 DURA LIGHT 	6 Allen Key (5mm) 	
LIGHT Qty: 2	Part (M5) Qty: 1	

FORD F250/F350 Fog Kit



WIRING INSTALLATION

- 1) Take connectors shown in Figure 1 and plug them into the factory harness ensuring they clip in securely.
- 2) Plug the other end with the Deutsch connector into your Dura lights.

Figure 1



WARNINGS

As with many other high-tech products, this VISION X LED requires a bit of attention before you can use it. Please read the accompanying information carefully first.

- 1) Don't stare directly into the light or shine directly into the eyes of another person as this may cause temporary loss of vision.
- 2) Never disassemble the products, as all parts must be factory serviced to insure proper operation.
- 3) Don't interchange the parts inside this light with other products.
- 4) The LED light is to be mounted on the vehicle only in a vertical, bottom-mounting, or in a suspended position.
- 5) After turning on the light, the body might be hot enough to warrant a burn risk. Be careful when you touch the body after turning on the light for a long period of time.
- 6) Use the supplied wire harness for electrical installation.
- 7) The LED light must not adversely affect the performance of low beam, high beam, engine cooling or the driver's view.

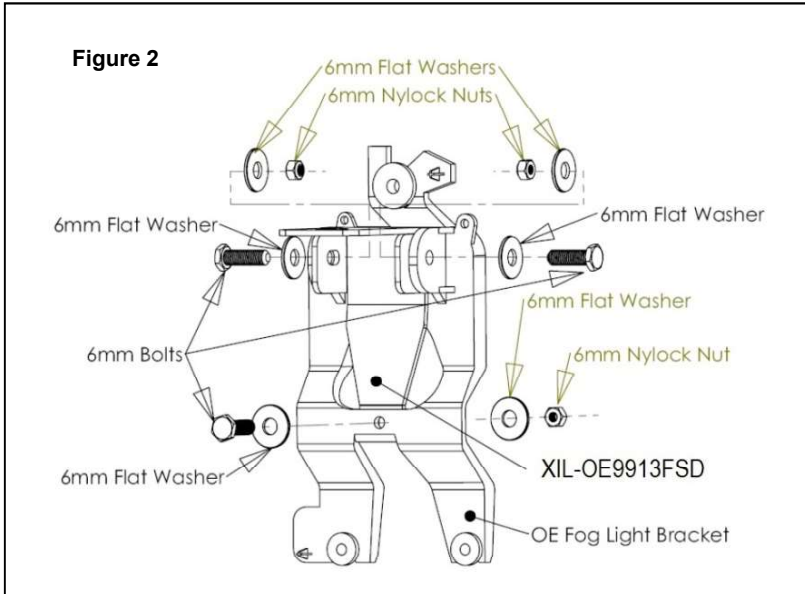

MOUNTING INSTALLATION (2011-14)

- 1) Disconnect negative battery terminal from the battery.
- 2) Remove the 4x 13mm bolts on the metal plate behind the fog light to gain access to the fog light bracket.
- 3) Disconnect fog light plug from factory fog light.
- 4) Each fog light bracket has 3x 8mm bolts holding it to the bumper, one above the light and two below. Remove all three bolts and take light assembly out of the bumper. Next remove the two plastic push pins on either side of the light and unscrew the adjuster screw at bottom of light.
- 5) Use the 3x supplied 6mm hardware to attach the new aftermarket metal bracket to your factory fog light bracket. (See Figure 2 for reference)
- 6) Aim the light as desired and tighten the allen bolts down on the light.
- 7) Mount the entire assembly back in the bumper and re-attach with the factory 8mm bolts

Installation Instructions & User's Manual



FEATURES

- 1) Adds up to 3,944 lumens of light to your Ford Superduty
- 2) No drilling required.
- 3) High grade powder coated steel

FORD SUPERDUTY FOG LIGHT KIT SPECIFICATIONS

- | | |
|----------------------|--------------------|
| 1) Vision X Warranty | : Extended |
| 2) Colors | : Black |
| 3) Beam Patterns | : 10° Beam Pattern |
| 4) LED Lifespan | : 50,000 Hours |

APPLICATION GUIDE

- 1) At this time this kit has been tested to fit 1999-2014 Ford Superduty F250/350
- 2) At this time this kit has been tested to mount DURA-410

PREPARATION

- 1) We recommend completely reading instructions before installing.
- 2) Consult your local or state regulatory agency regarding the use of LED lighting.

MAINTENANCE

- 1) All VISION X models have been designed for maintenance free use. In the case a LED lamp or other part replacement please contact your authorized service center.

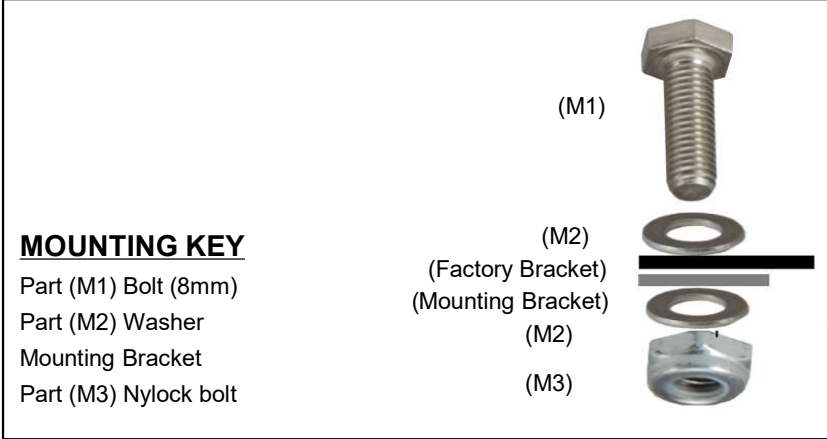

WARNING: Bolts, Nuts, & Washers are Stainless Steel.

Do Not Use Pneumatic or Electric Tools to Tighten & Loosen
or the Hardware Will Permanently Lock Together

LIGHT ANGLE ADJUSTMENT

- 1) Use the 5mm Allen Key [Part M5] to loosen each of the Allen Head Bolts [Part M4] on either side of the light.
- 2) Adjust the light until you have your desired angle.
- 3) Then, tighten the Allen Head bolts [Part M4] to hold the desired position.

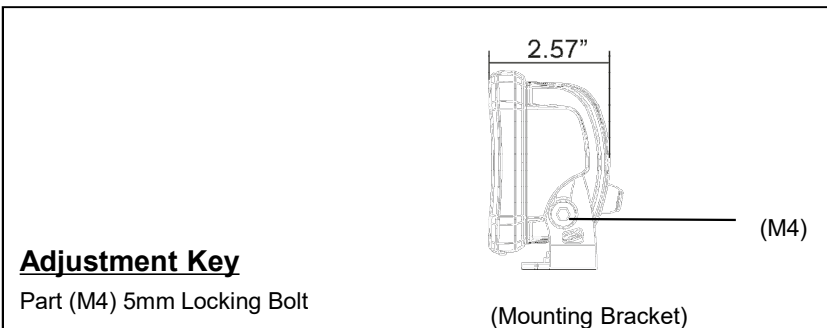

MOUNTING INSTALLATION (1999-04)

- 1) Disconnect negative battery terminal from the battery.
- 2) Disconnect fog light plug from factory fog light.
- 3) Each fog light bracket has 3x 8mm bolts holding it to the bumper, two above the light and one below. Remove all three bolts and take light assembly out of the bumper. Next remove the two plastic push pins on either side of the light and un-screw the adjuster screw at bottom of light.
- 4) Use the 3x supplied 6mm hardware to attach the new aftermarket metal bracket to your factory fog light bracket. (See Figure 2 for reference)
- 5) Aim the light as desired and tighten the allen bolts down on the light.
- 6) Mount the entire assembly back in the bumper and re-attach with the factory 8mm bolts

MOUNTING INSTALLATION (2005-07)

- 1) Disconnect negative battery terminal from the battery.
- 2) Disconnect fog light plug from factory fog light.
- 3) Each fog light bracket has 3x 8mm bolts holding it to the bumper, two above the light and one below. Remove all three bolts and take light assembly out of the bumper. Next remove the two plastic push pins on either side of the light and un-screw the adjuster screw at bottom of light.
- 4) Use the 3x supplied 6mm hardware to attach the new aftermarket metal bracket to your factory fog light bracket. (See Figure 2 for reference)
- 5) Aim the light as desired and tighten the allen bolts down on the light.
- 6) Mount the entire assembly back in the bumper and re-attach with the factory 8mm bolts

MOUNTING INSTALLATION (2008-10)

- 1) Disconnect negative battery terminal from the battery.
- 2) Disconnect fog light plug from factory fog light.
- 3) Each fog light bracket has 3x 8mm bolts holding it to the bumper, one above the light and two below. Remove all three bolts and take light assembly out of the bumper. Next remove the two plastic push pins on either side of the light and un-screw the adjuster screw at bottom of light.
- 4) Use the 3x supplied 6mm hardware to attach the new aftermarket metal bracket to your factory fog light bracket. (See Figure 2 for reference)
- 5) Aim the light as desired and tighten the allen bolts down on the light.
- 6) Mount the entire assembly back in the bumper and re-attach with the factory 8mm bolts