

Instruction Manual

Instruction Rev00

VISIONXOFFROAD.COM



CR3 Fog Light Mounting Kit Jeep Wrangler JK/JL Jeep Gladiator JT XIL-OEJEEP1CR

Thank you for choosing VISION X

We know you would rather be riding your bike than wrenching on it, so we go the extra mile to make sure our instructions are clear and as easy to understand as possible. If you have any questions, comments, or suggestions don't hesitate to give our gear experts a call at (888) 489-9820 or visit WWW.VISIONXOFFROAD.COM

Please Read Before Installing

VISION X products should always be installed by a qualified technician. If you are unsure of your ability to properly install a product, please have the product installed by your local dealer. VISION X takes no responsibility for damages caused by improper installation. **Caution:** When installing electronics it is extremely important to pay close attention to how wires are routed to ensure the wires will not bind and have enough slack to operate properly.

Installation Tips

We strongly recommend using medium strength liquid thread locker on all screws, nuts, and bolts. It is also important to ensure that all hardware is tightened to the proper torque specifications as listed in your owner's manual. For included accessory hardware please refer to the default torque specifications provided below. Inspect all hardware after the first 30 miles to ensure proper torque specifications are maintained.

Bolt Size	in-lbs	ft-lbs	Nm
M3	10.0 in-lbs	-	1.0 Nm
M4	23.0 in-lbs	-	2.5 Nm
M5	44.5 in-lbs	3.5 ft-lbs	5.0 Nm
M6	78.0 in-lbs	6.5 ft-lbs	9.0 Nm
M8	-	13.5 ft-lbs	18.0 Nm
M10	-	30.0 ft-lbs	41.0 Nm
M12	-	52.0 ft-lbs	71.0 Nm

Hardware Sizing Guide

Not sure what size bolt you have? Use this ruler to measure screws, bolts, spacers, etc. Remember, the length of a screw or bolt is measured from the start of the "mounting surface" to the end of the screw, so only include the screw head when measuring countersunk screws.

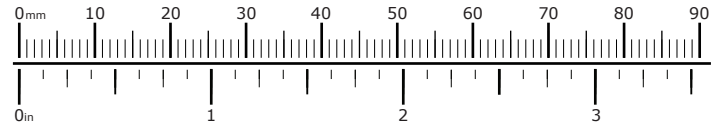

What's In The Box?



Kit Contents

- (a) Mounting Bracket.....Qty 2
- (b) M4x12 Thread Forming Screw.....Qty 8
- (c) H16 Wiring Adapter.....Qty 2
- (d) H10 Wiring Adapter.....Qty 2

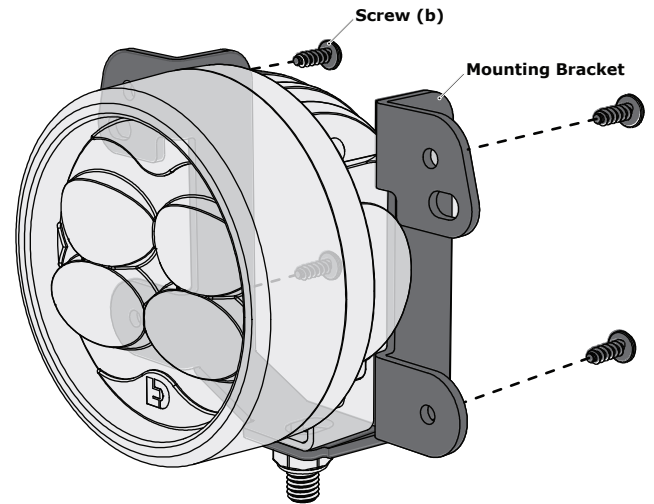
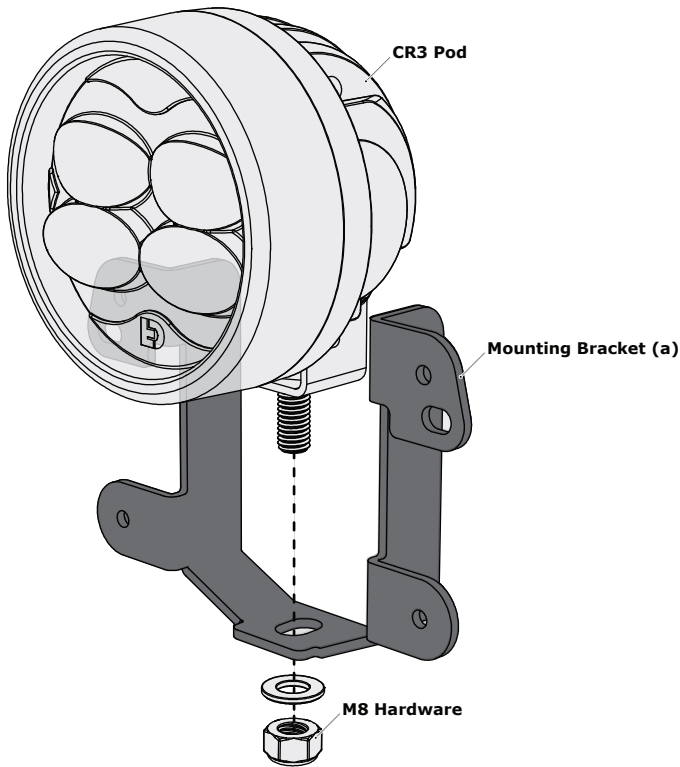

1.1 - Installing The Mounting Bracket

This CR3 Light Mounting Kit is designed to replace the OEM fog lights for Jeep Wrangler JK/JK and Jeep Gladiator JT. The CR3 lights will plug directly into the OEM harness and will be controlled from the original fog light switch.

Step One: The mounting bracket will be installed to the original hinge of the CR3 pod. Use the 13mm wrench and the M8 hardware that was included with your light pod to attach the bracket to the pod.

1.2 - Installing The CR3 Fog Light

Step Two: The OEM fog lights and brackets now need to be removed from the vehicle. The OEM lights can be accessed from behind the front bumper depending on your exact vehicle model, the plastic splash guard may need to be removed to access the lights.

Step Three: Once the OEM fog lights have been removed, the CR3 lights can be installed into the bumper, reversing the steps used to uninstall the OEM fog lights.

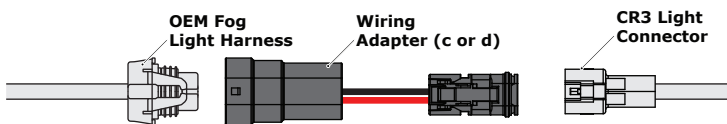

1.3 - Connecting The CR3 Fog Light

Step Four: Once installed, use the provided wiring adapter (c or d) to connect the CR3 light to the OEM wiring harness. Use the adapter which matches the OEM connector on your vehicle.