

BC X-PRO 130 – USER MANUAL

Thank you for purchasing the new professional battery charger and power supply unit **BC X-PRO 130**. Please read carefully this manual, which provides the operating instructions for the product and indicates all precautions and warnings to be observed for your safety. Keep the manual with care for future reference, and follow all instructions before and during use of the device.

FEATURES

BC X-PRO 130 is a professional battery charger and power supply unit with automatic multi-cycle charging technology. Developed to ensure a stable voltage on 12V vehicles during diagnosis operations and flash programming, it also allows to recover, recharge and maintain all 12V batteries.

Its compact size and reduced height (10 cm) make it ideal for powering vehicles on display in showrooms, allowing it to be easily positioned under any car.

The device is supplied with 3 meter long battery connection cables with insulated terminals.

BC X-PRO 130 has 4 different modes/programs to choose from:

- **Battery Charger:** for the recovery, charging and maintenance of all starting batteries (traditional, sealed, gel, AGM/EFB Start&Stop, Calcium-Calcium and lithium). It is possible to select the battery type, the charging current, the maximum Ah to recharge and the maximum charging time. Range of use:

- 12V batteries from 1 Ah to 1300 Ah (current min-max: 1 Amp - 130 Amp)

BC X-PRO 130 can also be used for the **partial charging of lithium batteries (25%, 50%, 75%, 100%)**: in fact, lithium batteries must be stored at a charging percentage around 25%, according to the regulations in force in the European Union (see the manufacturer's instructions in this regard).

- **Power Supply / Voltage Stabilization:** this program allows to keep a stable voltage during diagnosis operations and flash programming on the vehicle, compensating for the energy absorption of the on-board devices (fan, electronic suspension, electric windows...). It is possible to select the output voltage of the device in the range from 12.8V to 14.8V as well as the maximum supplied current.

- **Memory Saver for Battery Replacement:** selecting the Power Supply mode and the output voltage of 12.8V, it is possible to safeguard the vehicle's memories during battery replacement.

- **Showroom:** the showroom mode allows an automatic restart of the device whenever it is turned back on. It can be activated in both the following modes:

- **Power Supply:** it allows to power the vehicles on display, compensating for the current absorbed by the on-board instruments (headlights, on-board computer, electric windows, heating...) that are normally used or turned on in showrooms for vehicle demonstrations. When the Showroom mode is active, in the event of a power failure, BC X-PRO 130 restarts automatically when the electricity is restored, allowing it to be left connected with no need for intervention by showroom personnel.
- **Battery Charger:** when the showroom mode is active, in the event of a power failure, BC X-PRO 130 restarts automatically when the electricity is restored, starting to charge the battery again. The device also keeps in memory the Ah provided to the battery: when the device is turned back on, it resumes counting Ah starting from the value reached at the last shutdown.

SAFETY AND WARNINGS

This device has to be used according to the working conditions it has been designed for within the limits indicated in this manual. Any other use is to be considered either dangerous or improper. Please strictly comply with all safety instructions. The manufacturer is completely exonerated from whatever responsibility for possible damages due to either wrong, unreasonable or improper use of the device.

- The device is suitable for indoor use. Do not use the device outdoor and do not expose the device to the atmospheric agents (rain, water, saltiness...).
- The device is not intended for use by children or persons with reduced physical, mental or sensory capabilities, or lack of enough experience and knowledge to understand the instructions on this manual, except in the presence of a responsible person who can ensure the safe use of the device. Keep out of reach of children and ensure that they cannot play with it.
- Do not use the device to charge NiCd, NiMH or non-rechargeable batteries.
- Please verify that the input and output cables are in good conditions before using the device. If the input cable is damaged, do not use the device: ask the manufacturer or an authorized service agent for repair or replacement. Do not connect the device to a damaged power outlet.
- Do not try to recharge a frozen or damaged battery.
- Do not cover the device during use.
- Do not place the device close to heat sources. Do not use in environments with temperatures above 50°C. In Power Supply mode, the device is designed to work at maximum power with ambient temperatures up to 30°C.
- The operating mode of the device and the restrictions applicable to its use are explained in the following sections of this manual.
- During the charging, a battery might produce explosive gases: avoid generating flames or sparks in its proximity and place the battery in a well ventilated area, to avoid any risk of fire or explosion. Protect the battery surface from any risk of short circuits.
- Batteries contain a corrosive electrolyte. Wear protective goggles and gloves when operating in proximity of the battery. In case the acid gets in touch with your skin or eyes, rinse them immediately with plenty of water and ask for a doctor.

CONNECTION OF BC X-PRO 130

- Before connecting/disconnecting the device to/from the battery, turn off the switch and disconnect the device from the power outlet.
- Connect first the battery terminal not connected to the chassis (usually the positive one, red clamp to the positive + pole of the battery), then connect the other clamp to the chassis, far from the battery, the fuel line and the tank. Then, connect the device to the power outlet and turn on the switch.
- After using the device, turn off the switch and disconnect the device from the power outlet first, then disconnect the clamp connected to the chassis, then disconnect the clamp connected to the battery, in this order.
- **WARNING:** The charger must be connected to an earthed power outlet. The connection to the power outlet must be carried out in compliance with national standards.

START UP OF BC X-PRO 130

1. Connect the device to the power outlet.
2. Turn on the device, placing the switch on "I". The digital display turns on, showing «BC X-PRO - fw x.x»
3. The charger is set to the last configuration used. To change the operating mode (Battery Charging, Power Supply...), the parameters (battery type, current, voltage...) or the language, follow the instructions in the next paragraphs.

SELECTION MENU

BC X-PRO 130 is provided with a push-button panel that allows to select the operating mode, the related parameters and the display language.

To enter the selection menu, keep pushed the “ON/OFF - SELECT” button for 5 seconds.

NB: every time you turn on BC X-PRO, it is necessary to wait for the initialization to be complete before entering the menu.

Menu items:

- **Mode:** it allows to choose the operating mode between Battery Charger and Power Supply.
- **Safety:** it allows to set up several safety parameters for battery charging (battery test, maximum Ah, maximum charging time)
- **Language:** it allows to select the display language.
- **Showroom:** it allows to set the automatic restart in both Battery Charger and Power Supply modes (exception for Power Supply mode with 12.8V output voltage selected).

To move between the menu and submenu items, use the arrow keys and confirm the choices with the “ON/OFF - SELECT” button. If no key is pressed for 40”, the device automatically exits the selection mode and restarts with the previous configuration. It is possible to exit the menu at any time without confirming the choices, keeping the “ON/OFF - SELECT” button pressed for 5 seconds.

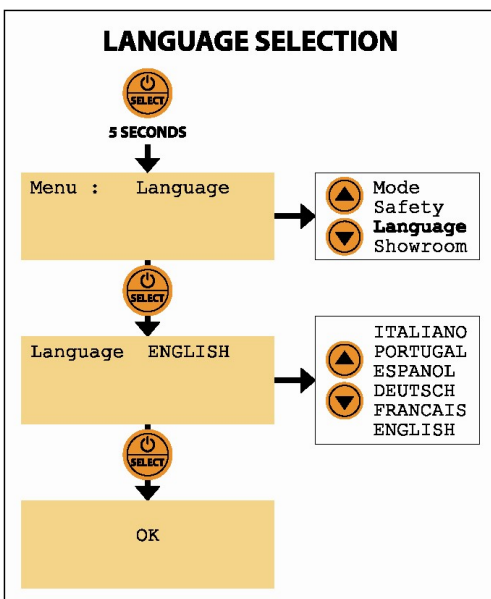

LANGUAGE SELECTION

You can select the display language of the BC X-PRO 130 from 6 different languages. Proceed as follows:

1. Press and hold the “ON/OFF - SELECT” button for 5 seconds to access the menu.
2. Press the arrow keys until you reach Menu: Language. Press “ON/OFF - SELECT” to confirm.
3. Select the desired language with the arrow keys: ENGLISH – ITALIANO – PORTUGAL – ESPANOL – DEUTSCH – FRANCAIS
4. Press the “ON/OFF - SELECT” button to confirm the selection.

OPERATING MODE – BATTERY CHARGER

In Battery Charger mode, BC X-PRO 130 is equipped with different charging algorithms for different types of 12V starting batteries. Before connecting the device to the battery, make sure to correctly select the battery type and the maximum charging current, depending on the battery to be recharged (follow the instructions in the following paragraph).

The following battery types can be selected:

- **STD/MF:** it executes an automatic multi-cycle charging algorithm suitable for the recovery, charging, desulfation and maintenance of all lead-acid traditional (with liquid electrolyte) and sealed starting batteries (maintenance-free and gel batteries). If it is necessary to recharge a traditional battery, check the electrolyte level and fill up to the level recommended by the battery manufacturer, if necessary.

WARNING

When using the BATTERY CHARGER mode, select a maximum charging current equal to one tenth of the battery capacity in Ah or to the value immediately higher in the scale of the selectable values - ex: for a battery with a capacity of 80 Ah, maximum current 10.0 A (except lithium batteries).

- **AGM/EFB:** perfect charging algorithm for batteries installed on vehicles equipped with Start & Stop systems, which require a different charging curve with higher voltages.
- **Ca/Ca:** select this type to recharge calcium-calcium or lead-calcium batteries.
- **Litio:** specific charging algorithm for the new generation of lithium-ion or lithium-iron-phosphate starting batteries. It is possible to execute a **partial charge** for lithium batteries by selecting the charging percentage to be reached: 25%, 50%, 75%, 100%. In fact, it is advisable to keep lithium batteries in stock / on shelf at a charging percentage around 25/50% (see manufacturer's instructions), to increase their life span

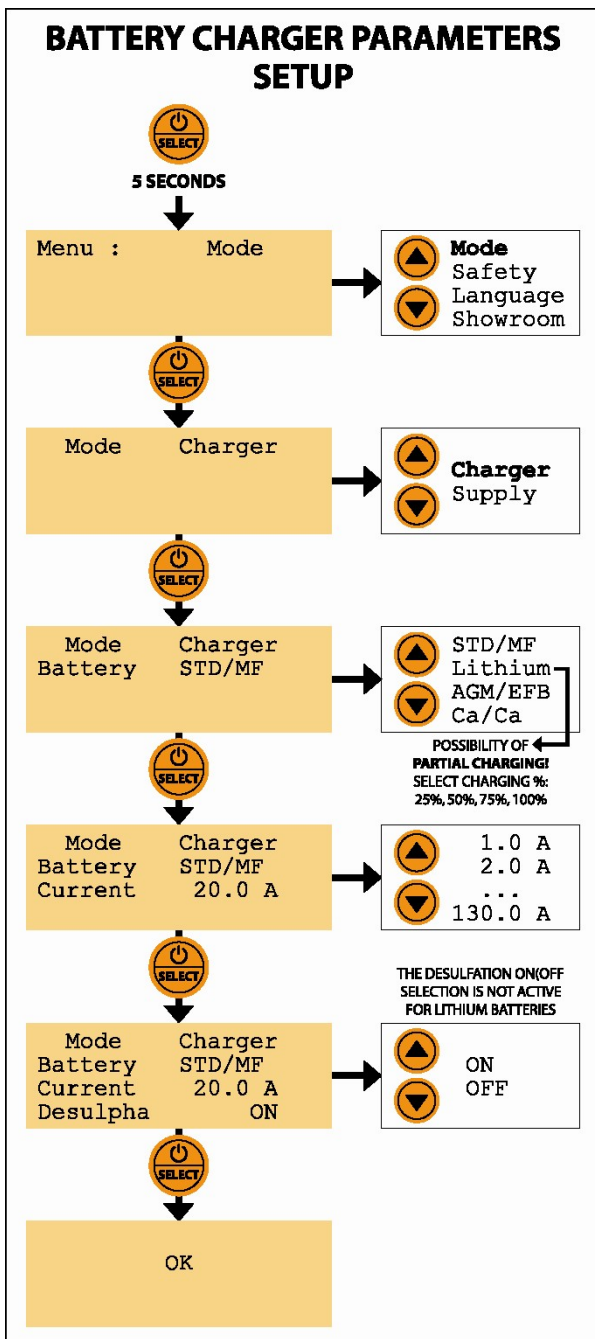

CHARGING MODE & PARAMETERS SELECTION

Before connecting the device to the battery, select the "CHARGER" operating mode and set the charging parameters as follows:

1. Press and hold the "ON/OFF - SELECT" button for 5 seconds to access the menu.
2. Press the arrow keys until you reach Menu: **MODE**. Press "ON/OFF - SELECT" to confirm.
3. Select the operating mode **CHARGER** with the arrow keys. Press the "ON/OFF - SELECT" button to confirm the choice.
4. Select the battery type with the arrow keys: **STD/MF – Lithium – AGM/EFB – Ca/Ca**. Press the "ON/OFF - SELECT" button to confirm the choice.
5. Select the maximum charging current with the arrow keys. **Note: select a maximum charging current equal to a tenth of the battery capacity, or to the value immediately higher in the scale of selectable values (ex: for a battery with a capacity of 80 Ah, maximum current 10.0 A). When charging lithium batteries, it is possible to select a higher maximum charging current, but a slow charge is recommended anyway.** Comply with the battery manufacturer's instructions and instructions for the maximum recommended charging current. Press the "ON/OFF - SELECT" button to confirm the choice.
6. Only for Lithium batteries: select the charging percentage to be reached (25%, 50%, 75%, 100%). Press the "ON/OFF - SELECT" button to confirm the choice.
7. For all other batteries: select Desulph. ON/OFF to enable or disable the desulphation cycle. It is recommended to set this parameter as ON for used batteries, OFF for new batteries. Press the "ON/OFF - SELECT" button to confirm the choice.

The display shows "OK". BC X-PRO 130 restarts and shows all parameters set in the "Mode" and "Safety" menus.

After the initialization is complete, the first row of the LCD display always shows the chosen parameters. The second row shows: "Load not connected!".

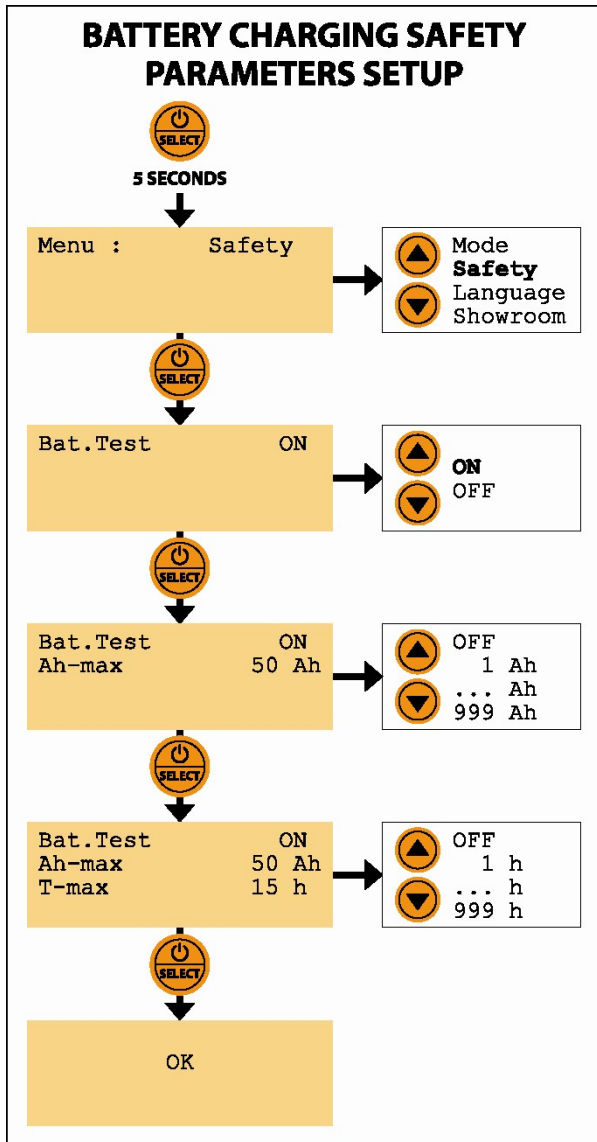

SELECTION OF SAFETY PARAMETERS FOR CHARGING

It is possible to select several customized additional settings for the Battery Charger operating mode by following the procedure below:

1. Press and hold the "ON/OFF - SELECT" button for 5 seconds to access the menu.
2. Press the arrow keys until you reach Menu: **SAFETY**. Press "ON/OFF - SELECT" to confirm.
3. Select **Battery Test ON/OFF** to choose whether to execute the battery cells check at the end of the Recovery, Soft Charge and Bulk Charge cycles. Press the "ON/OFF - SELECT" button to confirm the choice.
4. Set the maximum Ah value to supply to the battery (optional), from 1 to 999 Ah. Hold the arrow key pushed to increase/decrease quickly the value. The standard setting of the device does not provide for a maximum limit of Ah. To disable the limit, press the arrow button ↓ until you reach OFF. Press the "ON/OFF - SELECT" button to confirm the choice.
5. Set the maximum time for battery charging (optional), from 1 to 999 ore (h). Hold the arrow key pushed to increase/decrease quickly the value. The standard setting of the device does not provide for a maximum charging time. To disable the limit, press the arrow button ↓ until you reach OFF. Press the "ON/OFF - SELECT" button to confirm the choice.

The safety parameters set in this way are saved in memory for subsequent uses.

START / STOP THE CHARGE:

Once the desired charging parameters have been selected, connect BC X-PRO 130 to the battery to be recharged (red terminal: positive pole - black terminal: negative pole), following the instructions reported in the paragraph: "Connection of BC X-PRO 130" and press the "ON/OFF - SELECT" button to start charging. At any time, it is possible to stop and restart the charging procedure by pressing the "ON/OFF - SELECT" button.

During charging, the display shows the following indications:

- Row 1: the selected charging parameters (battery type and maximum current)
- Row 2: SHOWROOM Mode ON/OFF
- Row 3: the current supplied by the battery charger and the battery voltage (state of charge)
- Riga 4: the ampere-hours delivered to the battery and the time elapsed since the beginning of the charging process

The display also shows any error or anomaly (load not connected, polarity inversion or short circuit, mains not connected...).

Once charging is complete, the charger automatically keeps the battery at an optimal voltage. It is recommended to reduce the vehicle's absorption to a minimum, turning off any superfluous loads during charging.

11 CYCLES CHARGING ALGORITHM – LEAD-ACID BATTERIES (STD/MF/AGM/EFB/CA-CA):

Step 1 - Initial Battery Check: it verifies that one or more battery cells are not short-circuited and therefore the battery is a proper condition to be recharged / recovered.

Step 2 - Recovery: if the battery is extremely discharged (starting from 1.25V), the device tries to recover it, in order to bring it to a higher voltage compatible with the following step.

Step 3 – Battery and Cells Short Circuit Check: it checks that the battery cells are not short-circuited before switching to the following step. To skip this test, select “Bat.Test OFF” in the Safety menu.

Step 4 - Soft Charge: if the battery is significantly undercharged, the device provides a light pulsing current to the battery, in order to overcome this critical phase.

Step 5 - Battery and Cells Short Circuit Check: it checks that the battery cells are not short-circuited before switching to the following step. To skip this test, select “Bat.Test OFF” in the Safety menu.

Step 6 - Bulk Charge: during this cycle the battery charger provides full current to the battery, which can recover in this step up to 85-90% of its capacity.

Step 7 - Battery and Cells Short Circuit Check: it checks that the battery cells are not short-circuited before switching to the following step. To skip this test, select “Bat.Test OFF” in the Safety menu.

Step 8 - Desulphation / Absorption: in this step the device provides the battery with a “controlled overcharge” in order to restore the remaining 10-15% of the battery capacity, through the desulphation / recovery of the lead-acid cells (for mild or medium sulphation levels). It is possible to skip this charging cycle by setting “Desulphation OFF” in the menu Mode -> Charger.

Step 9 - Battery Check at End of the Charging Cycle: the device stops providing current for a few tens of minutes and verifies that the battery is able to retain the charge received during the previous charging cycles. The test is periodically repeated at regular intervals during maintenance.

Step 10 - Maintenance: thanks to a specially designed electronic circuit, the device maintains the battery fully charged during periods of inactivity, sen without any overheating, overcharging or electrolyte loss.

Step 11 - Equalization: during long term maintenance, the device executes an equalization process each 30 days to re-balance the battery cells, avoiding the electrolyte stratification.

10 CYCLES CHARGING ALGORITHM – LITHIUM BATTERIES:

Step 1 - Initial Battery Check: it verifies that the battery is a proper condition to be recharged / recovered.

Step 2 - Recovery: if the battery is extremely discharged, the device tries to recover it, in order to bring it to a higher voltage compatible with the following step.

Step 3 - Battery and Cells Short Circuit Check: it checks that the battery cells are not short-circuited before switching to the following step. To skip this test, select “Bat.Test OFF” in the Safety menu.

Step 4 - Soft Charge: if the battery is significantly undercharged, the device provides a light pulsing current to the battery, in order to overcome this critical phase.

Step 5 - Battery and Cells Short Circuit Check: it checks that the battery cells are not short-circuited before switching to the following step. To skip this test, select “Bat.Test OFF” in the Safety menu.

Step 6 - Bulk Charge: during this cycle the battery charger provides full current to the battery, which can recover in this step up to 85-90% of its capacity.

Step 7 - Battery and Cells Short Circuit Check: it checks that the battery cells are not short-circuited before switching to the following step. To skip this test, select “Bat.Test OFF” in the Safety menu.

Step 8 - Equalization: the device recovers the remaining 10-15% of the battery capacity, and re-balances the state of charge of the different battery cells.

Step 9 - Battery Check at End of the Charging Cycle: the device stops providing current for a few tens of minutes and verifies that the battery is able to retain the charge received during the previous charging cycles. The test is periodically repeated at regular intervals during maintenance.

Step 10 - Maintenance: thanks to a specially designed electronic circuit, the device maintains the battery fully charged during periods of inactivity, sen without any overheating or overcharging.

OPERATING MODE – POWER SUPPLY / VOLTAGE STABILIZATION

The power supply mode allows maintaining a stable voltage during diagnostics and programming operations on the vehicle. Before connecting BC X-PRO 130 to the vehicle, please select the voltage to keep according to the indications in the following paragraph.

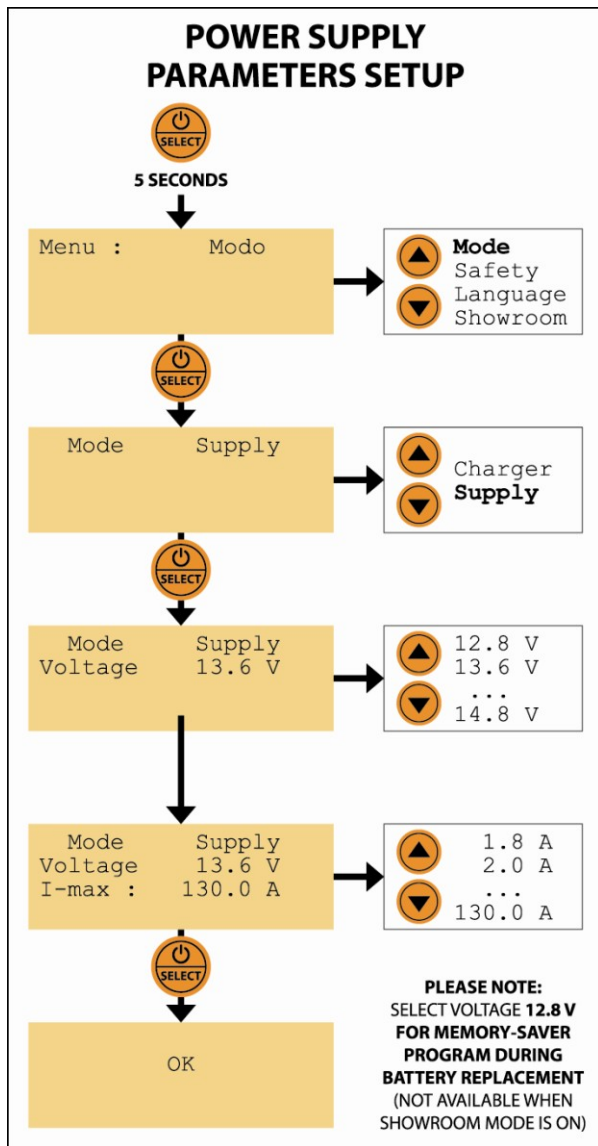

POWER SUPPLY MODE & PARAMETERS SELECTION

To select the "POWER SUPPLY" mode of BC X-PRO 130, please proceed as follows:

1. Press and hold the "ON/OFF - SELECT" button for 5 seconds to access the menu.
2. Press the arrow keys until you reach Menu: **MODE**. Press "ON/OFF - SELECT" to confirm.
3. Select the operating mode **SUPPLY** with the arrow keys. Press the "ON/OFF - SELECT" button to confirm the choice.
4. Select the voltage to stabilize with the arrow keys: **12,8V -> 13,6V -> 13,8V -> 14,0V -> 14,4V -> 14,8V**. Please refer to the vehicle manufacturer's instructions for the voltage level to keep during diagnostics operations. Press the "ON/OFF - SELECT" button to confirm the choice.
5. Select the maximum power supply current with the arrow keys, between 1 A and 130 A. Press the "ON/OFF - SELECT" button to confirm the choice.

The display indicates "OK". BC X-PRO 130 restarts and the first row of the display shows the chosen parameters. The second row shows: "Load not connected!".

START / STOP THE POWER SUPPLY:

Once the desired power supply parameters have been selected, connect BC X-PRO 130 to the vehicle (red clamp: positive pole – black clamp: negative pole), following the instructions in the paragraph: "Connection of BC X-PRO 130".

At any time, it is possible to stop and restart the charging procedure by pressing "ON/OFF - SELECT" button. During the power supply operation, the display shows the following indications:

- Row 1: the selected power supply parameters (voltage)
- Row 2: SHOWROOM mode ON/OFF
- Row 3: the current supplied by the unit and the voltage on the vehicle
- Row 4: power supply active (ON) or paused (OFF)
- Moreover, the display shows any working anomaly or error (load not connected, mains not connected...).

PLEASE NOTE: do not allow the positive and negative clamps of the device to touch and do not connect to the vehicle with reversed polarity! A polarity inversion could damage the vehicle's electronics.

OPERATING MODE – SHOWROOM

The “Showroom” function can be activated both in “Power Supply” mode and in “Battery Charger” mode:

- In Power Supply mode, as soon as the device is turned on or the current is restored, it checks whether there is a connection to the battery. If this check detects a connected battery, BC X-PRO 130 automatically starts the power supply, keeping the battery voltage at the set value.
- In Battery Charger mode, as soon as the device is turned on or the current is restored, it checks whether there is a connection to the battery. If this check detects a connected battery, BC X-PRO 130 automatically starts recharging the battery, restarting from the situation reached (Ah provided to the battery and elapsed time) before the mains supply was interrupted.

Example of use: the charging of a 120 Ah battery in a workshop is interrupted after charging 50 Ah in 5h10’, to switch off the mains supply at the end of the day. When the power is restored the following morning, BC X-PRO 130 will resume charging from the point reached, showing on the display the same data (Ah and charging time) that were indicated at the time of interruption.

To select the “SHOWROOM” mode of BC X-PRO 130, please proceed as follows:

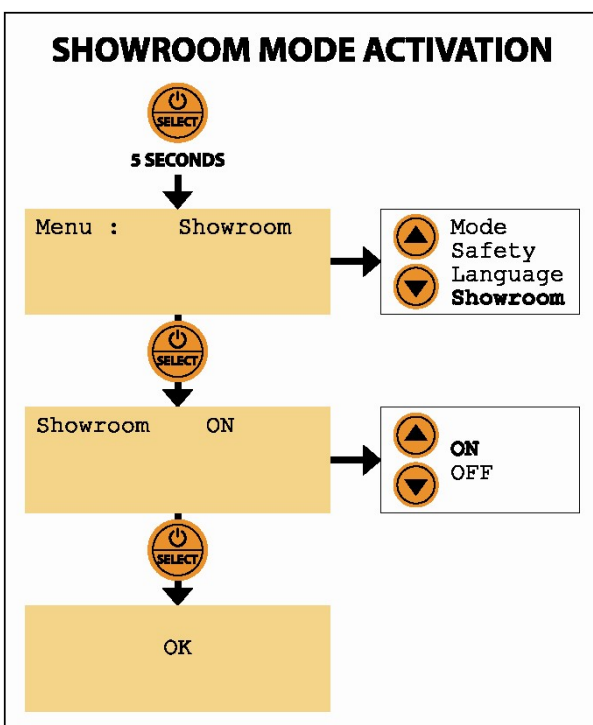

1. Press and hold the “ON/OFF - SELECT” button for 5 seconds to access the menu.
2. Press the arrow keys until you reach Menu: **SHOWROOM**. Press “ON/OFF - SELECT” to confirm.
3. To activate the SHOWROOM mode, select **ON** with the arrow keys. Press the “ON/OFF - SELECT” button to confirm the choice.

The display indicates “OK”. BC X-PRO 130 restarts with the last used configuration, and with SHOWROOM mode active. In the event of a power failure (for example, when the power is turned off in the showroom in the evening), the device is now ready to restart as soon as the power is restored.

When BC X-PRO 130 is connected to a battery in BATTERY CHARGER mode or to a vehicle in POWER SUPPLY mode, the second row always shows whether the SHOWROOM mode is enabled (ON) or disabled (OFF).

WARNING: it is necessary to set the desired charging or power supply parameters before connecting the device to the battery or vehicle. Proceed according to the

instructions in the previous sections of this manual. **The SHOWROOM mode cannot be enabled when the device is set in POWER SUPPLY mode with a voltage of 12.8V (Memory Saver Mode).**

OPERATING MODE – MEMORY SAVER FOR BATTERY REPLACEMENT

To use BC X-PRO 130 as a memory saver while replacing a vehicle’s battery, please proceed as follows:

1. Press and hold the “ON/OFF - SELECT” button for 5 seconds to access the menu.
2. Press the arrow keys until you reach Menu: **MODE**. Press “ON/OFF - SELECT” to confirm.
3. Select the operating mode **SUPPLY** with the arrow keys.
4. Press the “ON/OFF - SELECT” button to confirm the choice.
5. Select the voltage to stabilize with the arrow keys: **12.8V**.
6. Press the “ON/OFF - SELECT” button to confirm the choice.
7. Select the maximum power supply current with the arrow keys, between 1 A and 130 A.
8. Press the “ON/OFF - SELECT” button to confirm the choice.

The display indicates “OK”. BC X-PRO 130 restarts and the first row of the display shows the chosen parameters. The second row shows: “Load not connected!”.

Connect BC X-PRO 130 to the vehicle to be powered, making sure to firmly connect the red terminal to the end of the eyelet connector connected to the positive pole of the battery and the black terminal to the chassis (or to the end of the eyelet connector connected to the negative pole of the battery).

Make sure the connection is stable and secure and that the power supply status is "ON" before disconnecting the battery from the vehicle, to avoid data loss. Proceed replacing the battery with correct polarity and making sure that the terminals of BC X-PRO 130 do not disconnect from the vehicle.

Once the new battery is installed, press the "ON/OFF - SELECT" button to stop providing the power supply and then disconnect the terminals from the vehicle.

PROTECTIONS

BC X-PRO 130 is able to provide the operator with the following set of active protections during installation and use, while working in Battery Charger mode:

1. Protection against battery poles inversion.
2. Protection against short circuit (even for an indefinite time): no sparks!
3. Protection against overheating: the supplied current is automatically limited in case of excessive heating of the device.

It is recommended to pay particular attention when connecting to a vehicle in Power Supply mode: a polarity inversion or a short circuit could generate sparks and damage the vehicle's electronics. BC X-PRO 130 is provided with an internal protection fuse against connection mistakes by the user.

MAINTENANCE

- If the power cable is damaged, do not use the product but ask for replacement or repair by the manufacturer or by an authorized service center.
- Before executing any cleaning/maintenance operation on the device, please check the device is not connected to the power outlet.
- The battery charger is designed not to require any maintenance: please remove possible dust which may get accumulated on the cover of the device using a delicate detergent to avoid damaging the stickers. In case the device does not work properly, do not attempt to repair it; please ask either your local dealer or the equipment manufacturer (info@batterycontroller.it) for support. Any attempt to open unduly the device shall cause the withdrawal of the warranty.
- If the internal fuse is damaged, please ask the device manufacturer or an authorized service center for replacement.

DISPOSAL OF THE DEVICE

The device must be disposed of in accordance with the WEEE regulation for the disposal of Waste Electrical and Electronic Equipment. Do not dispose of it with normal household waste.

DECLARATION OF CONFORMITY

The device is manufactured in compliance with current safety regulations and European Directives. Forelettronica Srl declares under its own responsibility that the BC X-PRO device complies with the following standards. Reference standards: 60335-1, 60335-2-29, 55014-1, 55014-2, 61000-3-2, 61000-3-3, 62233, 50581.

The device is CE marked. The declaration of conformity can be downloaded from our website.

TROUBLESHOOTING – BATTERY CHARGER OPERATING MODE

1. The display shows the error message: "Load not connected"

```
Charger STD/MF 25A
Load not connected!
---.- A      --.- V
---.- Ah     ---:-- T
```

No battery is connected to the device -> Check battery connection

2. The display shows the error message: "Short/Pol. Inverted"

```
Charger STD/MF 25A
Short/Pol. Inverted
---.- A      --.- V
---.- Ah     ---:-- T
```

Battery connected with reverse polarity -> Connect the red terminal to the battery positive pole (+) and the black terminal to the battery negative pole (-)

Short circuited battery -> Replace battery

Short circuit on the output of BC X-PRO 130 -> Please ask the manufacturer or an authorized service center for support

3. The display shows the error message: "Mains not connected"

```
Charger STD/MF 25A
Mains not connected
---.- A      --.- V
---.- Ah     ---:-- T
```

BC XPRO 130 not connected to power supply -> Connect the device to the mains and turn it on by putting the switcher in "I" position.

4. The display shows the error message: "Weak battery"

```
Charger STD/MF 25A
Weak battery
---.- A      --.- V
---.- Ah     ---:-- T
```

The Battery Check step detected that the battery is not able to retain the charge -> Replace the battery

5. The display shows the error message: "Psu internal error"

```
Charger STD/MF 25A
Psu internal error
---.- A      --.- V
---.- Ah     ---:-- T
```

Internal problem inside BC X-PRO 130 -> Please ask the manufacturer or an authorized service center for support

TROUBLESHOOTING – POWER SUPPLY OPERATING MODE

1. The display shows the error message: "Load not connected"

```
Supply          13.6V
Mains not connected
---.- A        --.- V
Status:         OFF
```

No load is connected to the device -> Check the connection of BC X-PRO 130 to the vehicle

2. The display shows the error message: "Short/Pol. Inverted"

```
Supply          13.6V
Short/Pol. Inverted
---.- A        --.- V
Status:         OFF
```

BC X-PRO 130 connected with reverse polarity -> Connect the red terminal to the positive pole (+) and the black terminal to the negative pole (-)

Short circuit on the output of BC X-PRO 130 -> Please ask the manufacturer or an authorized service center for support

3. The display shows the error message: "Mains not connected"

```
Supply          13.6V
Mains not connected
---.- A        --.- V
Status:         OFF
```

BC XPRO 130 not connected to power supply -> Connect the device to the mains and turn it on by putting the switcher in "I" position.

4. The display shows the error message: "Supply overload"

```
Supply          13.6V
Supply overload
---.- A        --.- V
Status:         OFF
```

The loads connected require too much current, BC X-PRO 130 cannot keep the set voltage -> Switch off or disconnect some loads.

5. The display shows the indication: "Correct Polarity?"

```
Supply          13.6V
Correct Polarity ?
---.- A        --.- V
---.- Ah      ---:-- T
```

When BC X-PRO 130 is connected to the vehicle in Power Supply operating mode and the detected voltage is below a predetermined threshold, the display asks the user to check that the polarity is correct before starting the power supply -> Please check that the red clamp is connected to the positive pole (+) and the black clamp to the negative pole (-). Then, press the button "ON/OFF - SELECT" to start the power supply.

WARNING: starting the power supply with reversed polarity could cause serious damage to the electrical and electronic parts of the vehicle!

6. The display shows the error message: "Overtemperature"

```
Supply          13.6V
Overtemperature
---.- A        --.- V
Status:         OFF
```

Overheating of BC X-PRO 130, the power supply is suspended -> Please check that the device is positioned in a ventilated environment, away from the sun or other heat sources, and that the air vent is not covered.

WARNING: BC X-PRO 130 is designed to work at maximum power with a maximum ambient temperature up to 30°C.

7. The display shows the error message: "Psu internal error"

```
Supply          13.6V
Psu internal error
---.- A        --.- V
Status:         OFF
```

Internal problem inside BC X-PRO 130 -> Please ask the manufacturer or an authorized service center for support

TECHNICAL DATA

Input Voltage	100-240V ac, 50/60Hz
Charging Voltage	13.8V-14.7V – nom. 12V
Charging Current (Battery Charger Mode)	selectable from 1A to 130A
Battery Types	12V lead (traditional, MF, gel, AGM, EFB), Ca/Ca and lithium
Battery Capacity	from 1.2 to 1300 Ah
Charging Algorithm	11 cycles (lead & Ca/Ca), 10 cycles (lithium)
Power Supply Voltage	selectable from 12.8V to 14.8V
Cable Section	25 mm ²
Cable Length	3 meters
Dimensions (L x l x H) – Handle excluded	37 x 24 x 10 cm
Dimensions (L x l x H) – Handle included	37 x 29 x 10 cm
Weight	4.6 Kg