

**FLEETWOOD FOLDING TRAILERS, INC.**  
**INSTALLATION INSTRUCTIONS**

1968H495

Revised February 2008

**PART NUMBER: 4757F6741 VANITY MATE**

For use with Element, Destiny, Americana, and Evolution Series (except E4).

**This package consists of the following:**

1	-	4757F6748	Vanity mate	2	-	4756-486	Screw
2	-	4741D9656	Rivet	2	-	1201C644	Lock Nut
1	-	4757-012	Vanity retainer	2	-	4758-116	Mounting brackets
3	-	4744-830	Nylon spacer	1	-	100-103	Peel rivet

**IMPORTANT NOTICE**

**These instructions are for the use of qualified individuals specifically trained and experienced in the installation of this type equipment. Persons not qualified shall not attempt to install this equipment nor interpret these instructions.**

**WARNING: Do not install vanity mate over stove as paper towels or items placed on vanity mate could ignite.**

Determine desired location for installation (most often above sink except on tip-out galleys). Check for interference of screen door, lights, canvas supports, shower, or wardrobe rack, etc. See attached location charts.

There are three holes in the mounting brackets to adjust their height. Make certain that you place a nylon spacer between the vanity mate frame and each mounting bracket. Then, install the mounting brackets with the screws and nuts provided.

Locate the vanity mate ½" away from the valance track. Mark the two holes using the mounting brackets as a template and remove vanity. Drill 3/16" holes for rivets.

**CAUTION: Minimal pressure must be used as not to drill completely through top assembly. Drill bit should penetrate no more than ¼".**

Position and attach vanity mate with rivets. Be sure mirror is facing interior of trailer. Swing vanity mate up against the top assembly to locate vanity retainer.

**NOTE:** ¼" minimum clearance is required between the vanity retainer and the vanity mate for proper retainer operation. Mark the hole. Remove retainer. Drill 3/16" hole for rivet.

**CAUTION: Minimal pressure must be used as not to drill completely through top assembly.  
Drill bit should penetrate no more than 1/4".**

Assemble nylon spacer, vanity retainer, and peel rivet. See insert on attached drawing. Rivet retainer in place. Check for proper operation.

# FIGURE 1

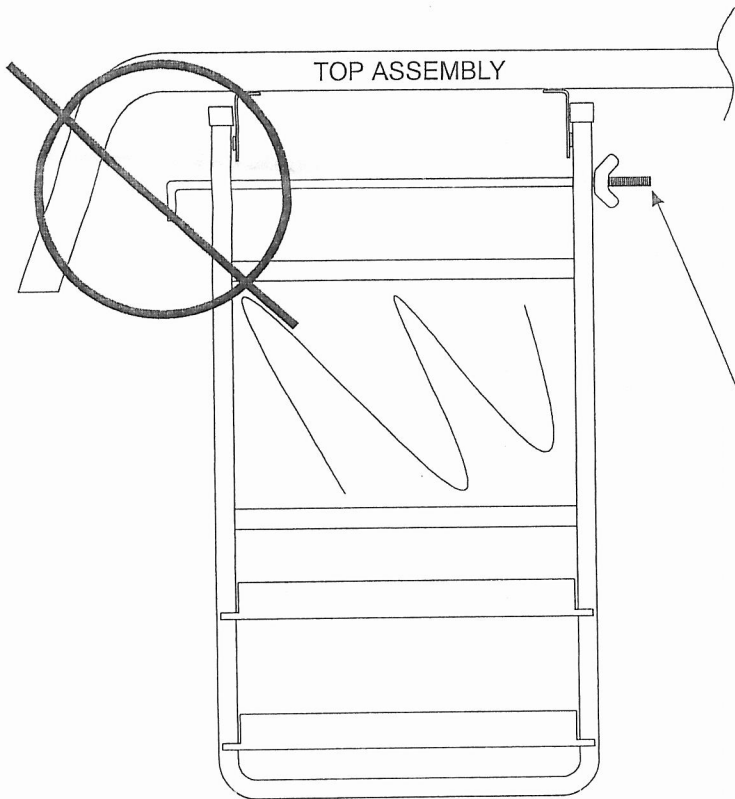

## VANITY RETAINER ATTACHMENT

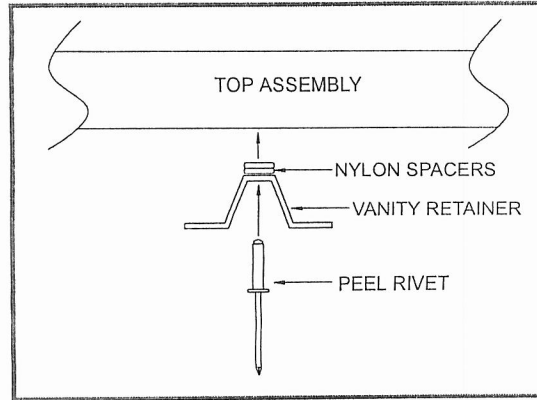

IT MAY BE NECESSARY TO REMOVE THE TOWEL BAR AND INSERT IT FROM THE OTHER END TO PREVENT INTERFERENCE WITH THE TOP ASSEMBLY.

## Tacoma

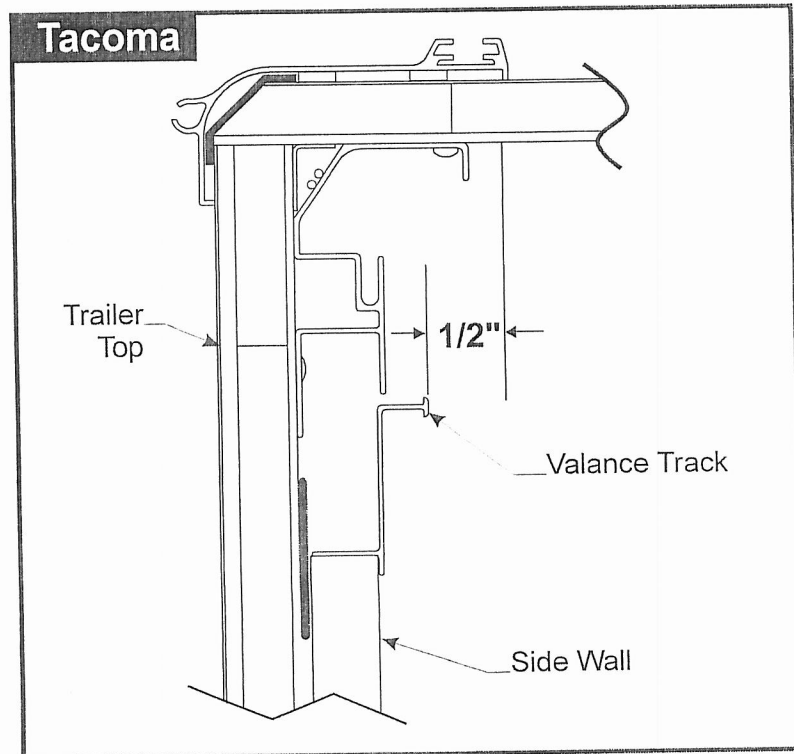

# 2007/2008 Vanity Mate Location

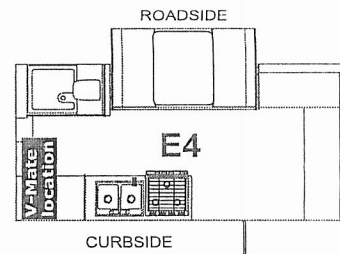
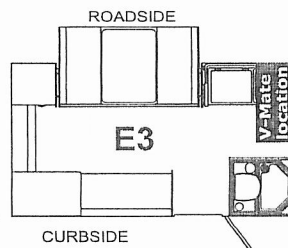
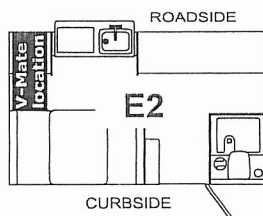
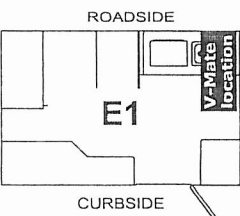
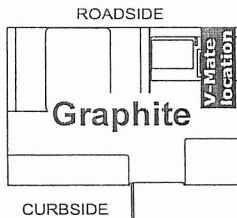
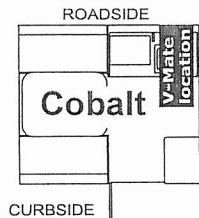
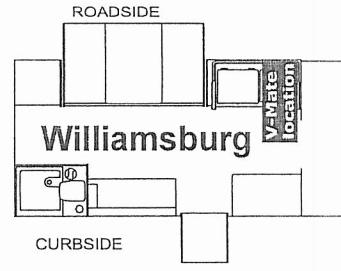
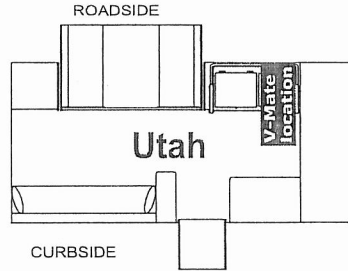
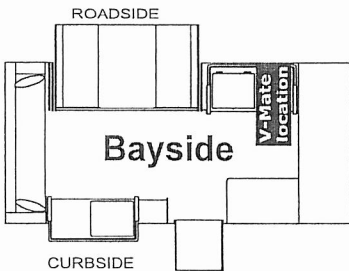
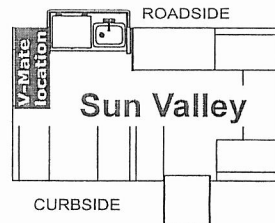
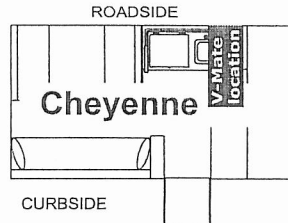
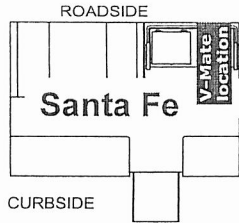
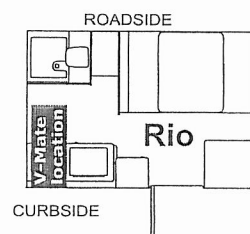
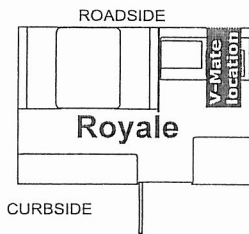
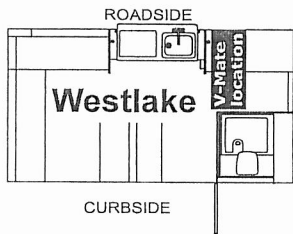
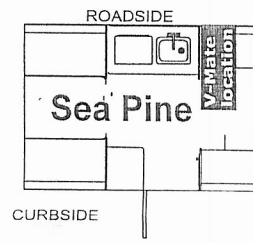
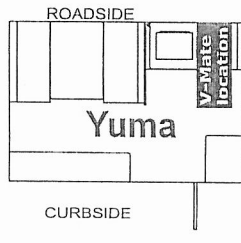
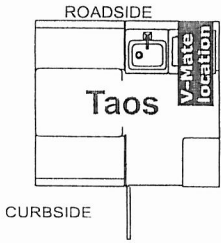

# 2007/2008 Vanity Mate Location

